

Proportional directional spool valves type PSL, PSV, PSM, size 5

Product documentation

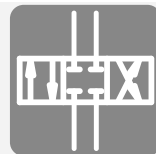

Series connection

Operating pressure p_{\max} :	400 bar
Flow rate (pump) Q_{\max} :	300 lpm
Flow rate (consumer) $Q_{\max A/B}$:	240 lpm

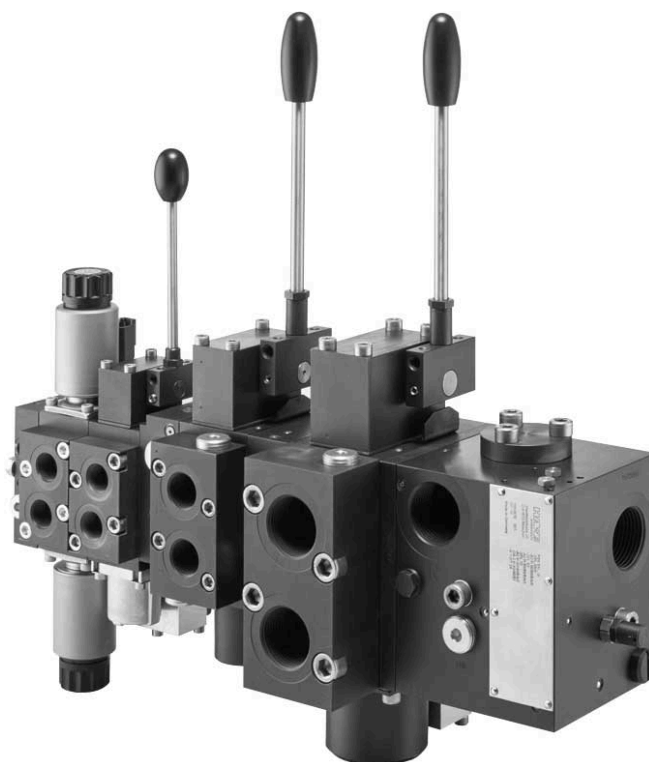

© by HAWE Hydraulik SE.

The reproduction and distribution of this document, as well as the use and communication of its contents to others without explicit authorization, is prohibited.

Offenders will be held liable for the payment of damages.

All rights reserved in the event of patent or utility model applications.

Brand names, product names and trademarks are not specifically indicated. In particular with regard to registered and protected names and trademarks, usage is subject to legal provisions.

HAWE Hydraulik respects these legal provisions in all cases.

HAWE Hydraulik cannot provide individual guarantees that the stated circuits or procedures (including in part) are not subject to the intellectual property rights of third parties.

Printing date / document generated on: 2023-02-10

Table of Contents

1	Introductory description of proportional directional spool valves type PSL, PSV, PSM, size 5.....	5
1.1	Configuration example PSL 5.....	6
1.2	Configuration example PSL 2 together with PSL 5, PSL 3 and EDL 2.....	7
2	Available versions.....	8
2.1	Connection block.....	9
2.1.1	Order coding, overview.....	11
2.1.2	Basic version.....	11
2.1.3	Ports for P and R.....	11
2.1.4	Connection block basic types.....	12
2.1.5	Additional elements for 3-way controller.....	17
2.1.6	LS damping elements.....	17
2.1.7	Internal control oil supply.....	17
2.1.8	LS relief or LS pressure limitation.....	18
2.1.9	System pressure limitation.....	20
2.1.10	Size.....	20
2.1.11	Variants and potential combinations.....	21
2.2	Valve section.....	22
2.2.1	Directional valve section.....	24
2.2.1.1	Consumer ports.....	24
2.2.1.2	Valve section, 2-way controller.....	25
2.2.1.3	2-way controller spring.....	26
2.2.1.4	2-way controller damping.....	27
2.2.1.5	Circuit symbol.....	28
2.2.1.6	Flow rate.....	30
2.2.1.7	LS pressure limitation.....	33
2.2.1.8	Electric LS relief or LS pressure limitation.....	35
2.2.1.9	LS port for external limitation.....	39
2.2.1.10	LS orifice.....	41
2.2.1.11	Shuttle valve.....	41
2.2.1.12	Additional functions.....	41
2.2.1.13	Actuation.....	42
2.2.1.14	Additional elements for actuation.....	46
2.2.1.15	Switching position monitoring, displacement transducer.....	47
2.2.2	Ancillary block.....	48
2.2.3	Intermediate plate (on the consumer side).....	53
2.3	Series intermediate plate.....	56
2.4	End plate.....	61
2.5	Solenoid voltage and solenoid version.....	67
2.5.1	Standard solenoid versions.....	67
2.5.2	Solenoid versions for potentially explosive atmospheres.....	69

3	Parameters.....	70
3.1	General information.....	70
3.2	Pressure and volumetric flow.....	71
3.3	Weight.....	71
3.4	Characteristic lines.....	73
3.4.1	Connection block.....	73
3.4.2	Directional valve section.....	74
3.5	Electrical data.....	77
3.5.1	Electro-hydraulic actuation with standard solenoid.....	77
3.5.2	Electro-hydraulic actuation with solenoid for potentially explosive atmospheres.....	79
3.5.3	Switching position monitoring, displacement transducer.....	80
3.5.4	Switching position monitoring, displacement transducer for potentially explosive atmospheres.....	81
3.5.5	Electric LS relief or LS pressure limitation.....	82
3.5.6	Electric LS relief or LS pressure limitation for potentially explosive atmospheres.....	84
3.5.7	Additional valves.....	84
4	Dimensions.....	85
4.1	Connection block.....	85
4.2	Valve section.....	96
4.2.1	Directional valve section.....	96
4.2.1.1	With integrated ports.....	96
4.2.1.2	For combination with an ancillary block.....	97
4.2.1.3	Pre-selector valve with integrated ports.....	98
4.2.1.4	With manual actuation.....	100
4.2.1.5	With electro-hydraulic actuation.....	105
4.2.1.6	With CAN actuation.....	111
4.2.1.7	With hydraulic actuation.....	112
4.2.1.8	With pneumatic actuation.....	114
4.2.1.9	Switching position monitoring, displacement transducer.....	115
4.2.1.10	LS pressure limitation.....	116
4.2.1.11	Electric LS relief or LS pressure limitation.....	117
4.2.1.12	LS port for external limitation.....	120
4.2.2	Ancillary block.....	122
4.2.3	intermediate plate.....	137
4.2.4	Series intermediate plate.....	141
4.2.5	End plate.....	147
5	Installation, operation and maintenance information.....	160
5.1	Intended use.....	160
5.2	Assembly information.....	160
5.2.1	Attachment.....	160
5.2.2	Piping.....	160
5.2.2.1	Reflux piping routed externally to the tank.....	161
5.2.3	Converting the connection block from PSL to PSV.....	162
5.2.4	Changing the valve spool.....	163
5.3	Operating instructions.....	164
5.4	Maintenance information.....	164
6	Other information.....	165
6.1	Accessories, spare and individual parts.....	165

1 Introductory description of proportional directional spool valves type PSL, PSV, PSM, size 5

Proportional directional spool valves are a type of directional valve. They control the direction of movement and the velocity of individual or multiple hydraulic consumers actuated simultaneously. Control is independent of the load and continuous.

The proportional directional spool valve type PSL is suitable for constant pump systems and type PSV is for variable pump systems. The flow rates and load pressures for the individual consumers can be individually adjusted. The proportional directional spool valve type PSL and PSV can be adapted to various control tasks, e.g. for safety functions. All sizes can be combined with each other.

The proportional directional spool valve type PSL and PSV is used in mobile hydraulics, in particular in loading cranes, lifting platforms, municipal trucks, construction machines, drilling equipment and machines for forestry and agricultural purposes.

Features and advantages

- Universally usable product for various flow rates and functions
- Extensive modular system with many variants and combination options
- Compact and lightweight design
- Robust and long-lived design for pressures up to 400 bar
- Highest energy efficiency thanks to low Δp and low-energy solutions

Intended applications

- Loading cranes
- Lifting platforms
- Municipal trucks
- Construction machines
- Drilling equipment
- Machines for forestry and agricultural purposes



Proportional directional spool valve type PSL 5

1.1 Configuration example PSL 5

PSL 5 1FBVE/400-5

-ZPL 55/9

-A2 H 120/120 A200 B300 /EA/5 AN220 BN350

-A2 L 160/160 A250 B200 FP23/EA/Z ALW-4-B 6/300/5 BL-4-B 6/250

-A2 O 160/120 A380 B200 S1/EA/5 DRH

-52 J 120/80 /EAWA-DT

-E 4-DT 24 K

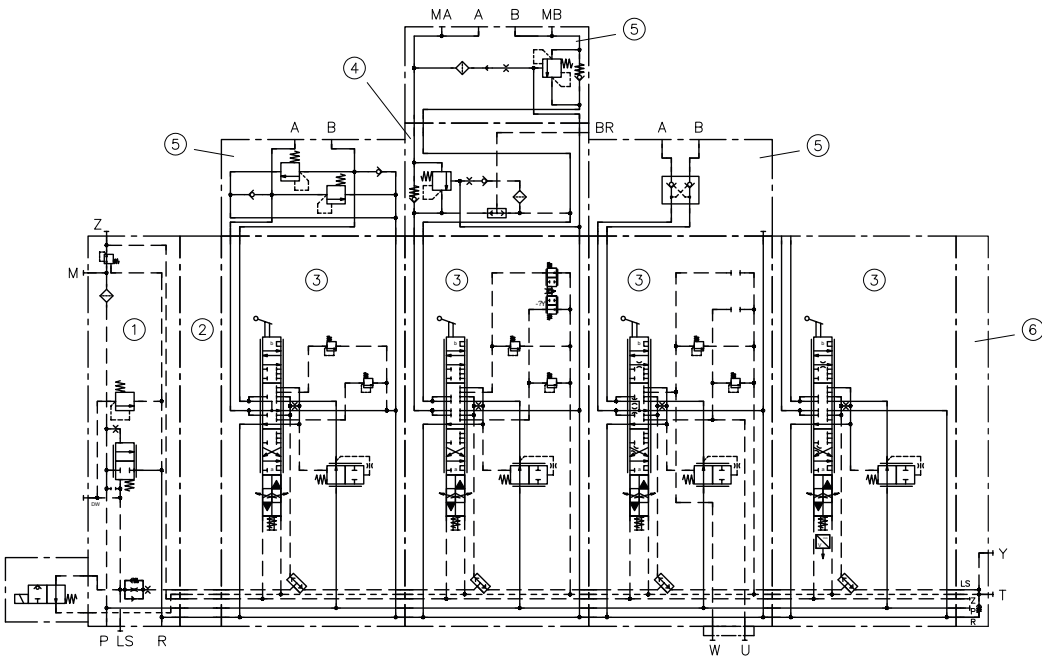

- 1 Connection block
- 2 Series intermediate plate
- 3 Valve section
- 4 Intermediate plate
- 5 Ancillary block
- 6 End plate

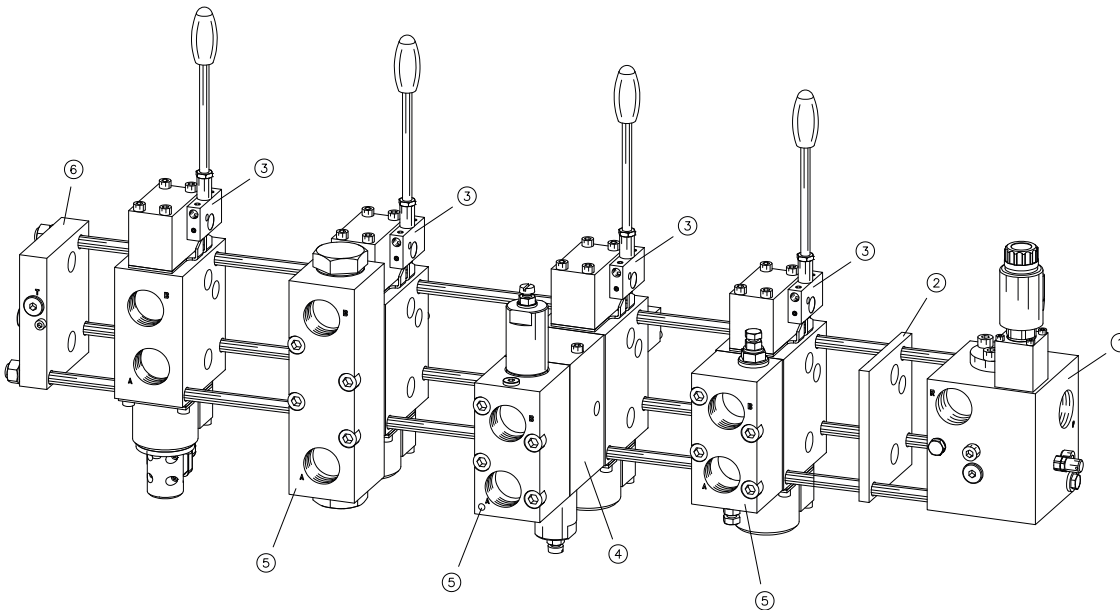

1.2 Configuration example PSL 2 together with PSL 5, PSL 3 and EDL 2

PSV 51/300-5
 - ZPL 55/9
 - A2 H 160/160/EA/5
 - ZPL 531
 - A2 H 80/80/EA/3
 - ZPL 32
 - A2 H 40/40/EA/2
 - DA2 H 40/40/EI/2
 - E 1-DT 24

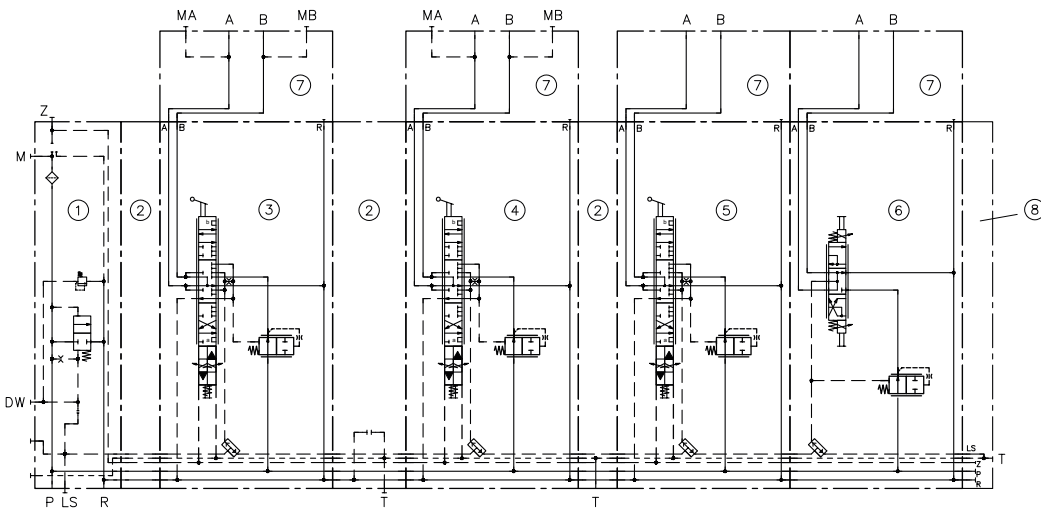

- 1 PSL 5 connection block
- 2 Series intermediate plate
- 3 PSL 5 valve section
- 4 PSL 3 valve section
- 5 PSL 2 valve section
- 6 EDL 2 valve section
- 7 Ancillary block
- 8 PSL 2 end plate

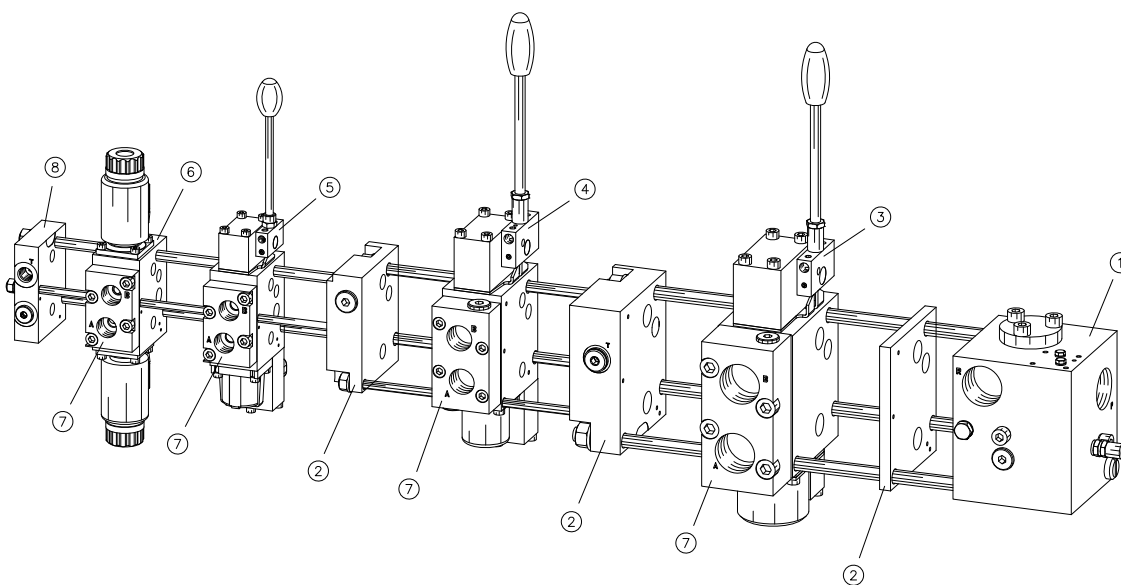

2 Available versions

Ordering example

PSL 5 B 1/400-5	Connection block (see Chapter 2.1)
-52 H 120/120 A250 B250/EA	Valve section (see Chapter 2.2)
-A2 L 160/160 A200 B300/EAWA-DT/5 AN230 BN320	Valve section with intermediate plate (see Chapter 2.2.3) and ancillary block
-A2 O 160/120/EA1/5 DRH	Valve section with ancillary block (see Chapter 2.2.2)
-A2 J 120/80 A250 B350/EA2/5 AN300 BN400	Series intermediate plate (see Chapter 2.3)
-E 4-DT 24	End plate with solenoid version and solenoid voltage (see Chapter 2.4, "End plate" and Chapter 2.5, "Solenoid voltage and solenoid version")

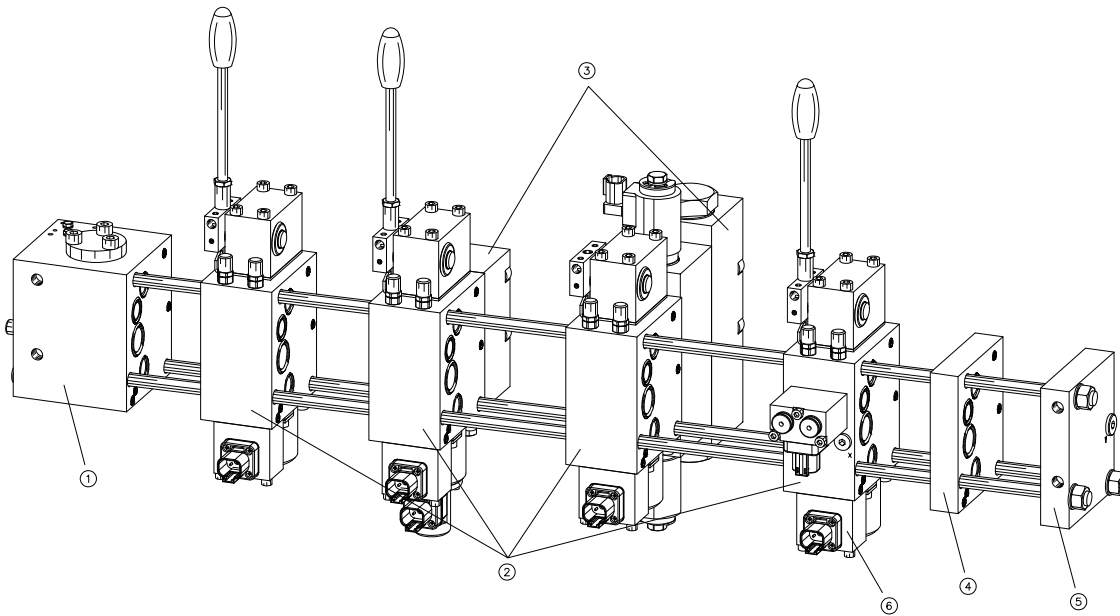

- 1 Connection block
- 2 Valve section
- 3 Ancillary block
- 4 Series intermediate plate
- 5 End plate
- 6 Solenoid voltage and solenoid version

A single manifold can merge up to 13 size 5 valve sections.

This number can be increased by combining with a PSL 3 or PSL 2. In this case, transition plates are used and each size has its own tension rod.

Limits to the maximum possible number of valve sections result from:

- a) tension rod strength
- b) internal control oil supply for the electro-hydraulic actuation
- c) the available control pressure difference for supply to the rear valve sections

2.1 Connection block

Connection blocks come in three basic variants:

- **PSL:** Connection block with integrated 3-way controller for use in Open Center systems with constant pumps
- **PSV:** Connection block without 3-way controller for use in Closed Center systems with variable pumps or for simultaneous supply of two or more manifolds from a shared constant pump
- **PSM:** Connection block capable of switching between Open Center and Closed Center

PSL

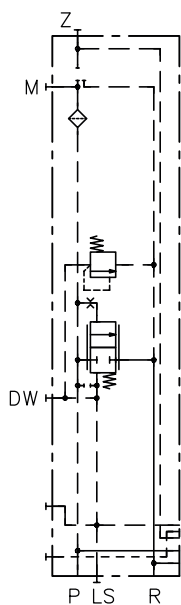

PSV

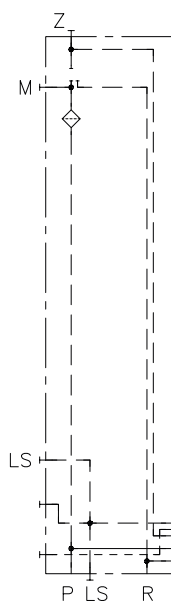

PSM

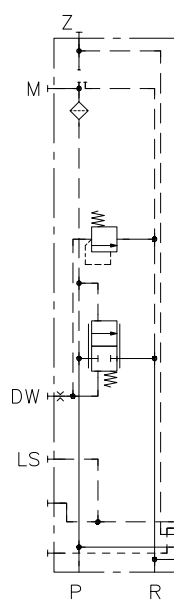

Depending on the configuration, the connection blocks incorporate:

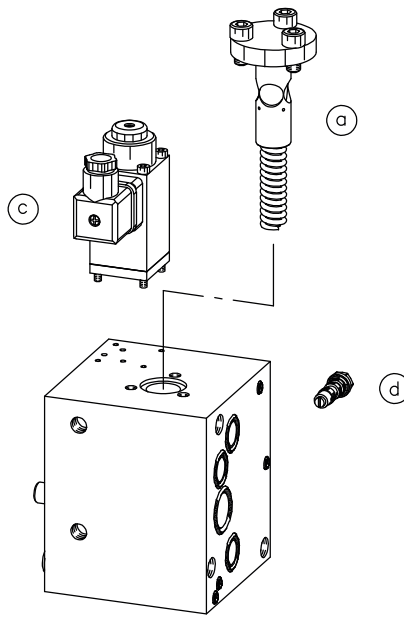
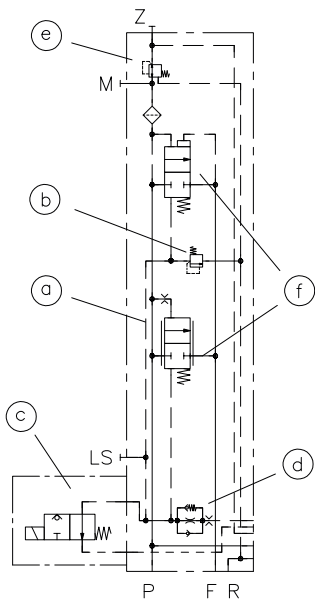

- a. 3-way controller for Open Center systems with constant pump
- b. Pressure-limiting valve to ensure maximum system pressure
- c. LS pressure limitation valve or LS release valve
- d. Damping element for the LS signal
- e. Pressure reducing valve for the control oil supply
- f. Additional elements e.g. idle circulation valve, power-beyond function, P-line shut-off, etc.

2.1.1 Order coding, overview

Ordering example

PSL	6	Y	H	G	1	F	/420	-5
								2.1.10 "Size"
								2.1.9 "System pressure limitation"
								2.1.8 "LS relief or LS pressure limitation"
								2.1.7 "Internal control oil supply"
								2.1.6 "LS damping elements"
								2.1.5 "Additional elements for 3-way controller"

- Basic type**
- 2.1.2 "Basic version"
 - 2.1.3 "Ports for P and R"
 - 2.1.4 "Connection block basic types"

2.1.2 Basic version

Type	Description
PSL	Connection block with integrated 3-way controller for use in Open Center systems with constant pumps
PSV	Connection block without 3-way controller for use in Closed Center systems with variable pumps or for simultaneous supply of two or more manifolds from a shared constant pump
PSM	Connection block capable of switching between Open Center and Closed Center

NOTICE

For instructions on how to convert the connection block from PSL to PSV, see [Chapter 5.2.3](#)

2.1.3 Ports for P and R

Coding	Description of P and R port
5	G 1 (ISO 228-1)
6	G 1 1/4 (ISO 228-1)
UNF 5	1 5/16-12 UN-2B or SAE-16 (SAE J 514)
UNF 6	1 5/8-12 UN-2B or SAE-20 (SAE J 514)
JIS 5	G 1 JIS (BSPP) B2351 type "O"

2.1.4 Connection block basic types

PSL connection blocks

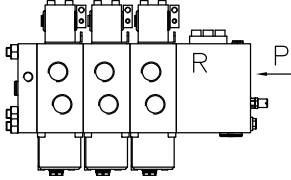
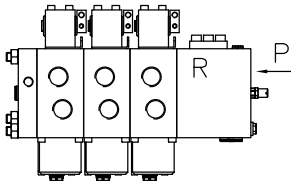
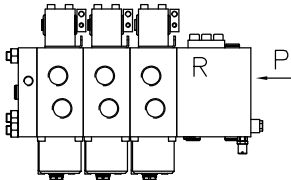
Type	Description
<p>PSL 5.../...-5 PSL 6.../...-5 PSL 6 UNF .../...-5 PSL JIS 5.../...-5</p>	<p>Connection block with integrated 3-way controller.</p> <p>Pressure-limiting valve: pilot-controlled P port: on side</p>  <div style="border: 1px solid black; padding: 5px; margin-top: 10px;"> <p>! NOTICE</p> <p>Where a valve section with ancillary block (coding A as per Chapter 2.2.2) is to be used below, at least one spacer plate -ZPL 55/9 (Chapter 2.3) must be used behind these connection blocks.</p> </div>
<p>PSL 5U.../...-5 PSL 6U.../...-5</p>	<p>Additional idle circulation valve for automatic reduction of circulation pressure.</p> <p>The idle circulation valve opens when the current LS pressure drops below 25% of the pump pressure. Electro-hydraulic actuation with internal control oil supply requires a pump flow rate of at least 150 lpm, pilot pressure will otherwise not suffice to shift the spool valve. Load pressure must be at least 20 bar.</p> <p>Pressure-limiting valve: pilot-controlled P port: on side</p> 
<p>PSL 6...UC22 2/...-5</p>	<p>To reduce the circulation pressure, especially at high flow rates.</p> <p>The circulation pressure can be reduced by an additional idle circulation valve (UC 22), which is controlled electrically. An LS relief or LS pressure limitation (Chapter 2.1.8) must be used for this.</p> <p>The idle circulation valve reduces circulation pressure to approx. 2.5 bar, resulting in improved energy efficiency in unpressurised circulation. It can be activated/deactivated by an electric pilot valve. Common applications are road vehicles with large constant pumps that frequently run in unpressurised circulation (e.g. municipal trucks).</p> <p>Pressure-limiting valve: pilot-controlled (additional idle circulation valve UC 22) P port: on side</p> 

Type	Description
PSL 6Y.../...-5	<p>Additional connection suitable for pressure loads for the 3-way controller's outflow (power beyond function).</p> <p>You can connect a second manifold to the F port. The first manifold's valve sections are prioritised. The downstream manifold receives the excess volume.</p> <p>Pressure-limiting valve: pilot-controlled P port: on side</p>

PSV connection blocks

Type	Description
PSV 5...-5 PSV 6...-5 PSV UNF 6...-5	<p>Connection block without 3-way controller.</p> <p>Pressure-limiting valve: without</p>
PSV 5.../...-5 PSV 6.../...-5 PSV UNF 6.../...-5 PSV JIS 5.../...-5	<p>Connection block without 3-way controller.</p> <p>Pressure-limiting valve: pilot-controlled</p>

Type	Description
PSV 5 N.../.../...-5 PSV UNF 5 N.../.../...-5	<p>P-line shut-off to safely shut off pump and consumer from one another and prevent undesired movements.</p> <p>The P-line incorporates a piston controlled by a 2/2-way directional valve. When unpowered, the piston securely seals the P-line, actuating the 2/2-way directional valve opens the P-line.</p> <ul style="list-style-type: none"> ▪ N: 2/2-way directional valve type EM 11 S as per D 7490/1 ▪ NM: with wing bolt for mechanical locking (EM 11 S-...-M) ▪ NP: with button for manual override (EM 11 ST) <p>Only in conjunction with LS damping (Chapter 2.1.6)</p> <p>Optionally, an additional LS release valve is available to depressurise the LS signal and switch the variable pump to standby pressure.</p> <ul style="list-style-type: none"> ▪ PSV (UNF) 5 N V: LS relief, closed when unpowered (EM 11 V as per D 7490/1) ▪ PSV (UNF) 5 N Z: LS relief, open when unpowered (EM 11 S as per D 7490/1) ▪ PSV (UNF) 5 N ZM: LS relief, open when unpowered, with wing bolt for mechanical locking (EM 11 S-...-M) ▪ PSV (UNF) 5 N ZP: LS relief, open when unpowered, with button for manual override (EM 11 ST) <p>Ordering example: PSV 5 N B 61ZM/220/200-5</p> <ul style="list-style-type: none"> – Setting for main pressure-limiting valve: 220 bar – Setting for LS pressure-limiting valve: 200 bar



NOTICE

When using a P-line shut-off, there is an additional pressure drop in the P-line that can lead to the downstream sections no longer reaching the nominal value.

The undershooting of the nominal value depends on the

- control pressure difference in the variable pump's pump controller,
- position of the valve section in the manifold and
- flow rate through the P-line shut-off.

The undershooting of the nominal value can reach up to 30% of $Q_{nominal}$, see "Flow rate".

Pressure-limiting valve: direct actuation
P port: at bottom

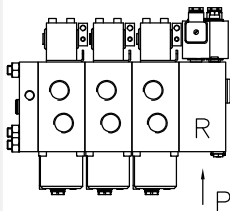

PSM connection blocks

Type	Description
PSM 5.../...-5 PSM 6.../...-5 PSM UNF 6.../...-5 PSM JIS 5.../...-5	<p>Connection block capable of switching between PSL (Open Center) and PSV (Closed Center).</p> <p>Switchover is performed using an external 3/2-way directional valve. (not included in scope of delivery)</p> <p>Pressure-limiting valve: pilot-controlled P port: on side</p>

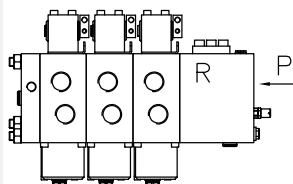

Circuit symbols

PSL 5.../...-5
PSL 6.../...-5
PSL 6 UNF.../...-5
PSL JIS 5.../...-5

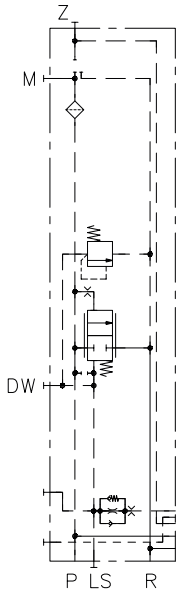

PSL 5U.../...-5
PSL 6U.../...-5

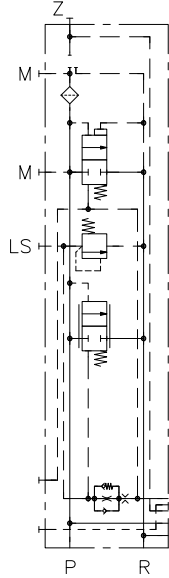

PSL 6...UC22 2/...-5

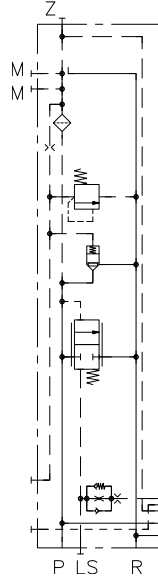

PSL 6Y.../...-5

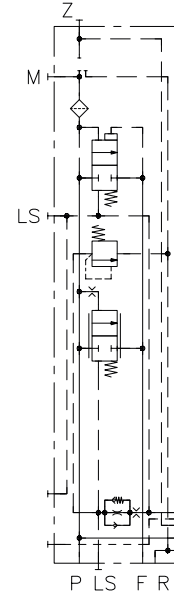

PSV 5...-5
PSV 6...-5
PSV UNF 6...-5

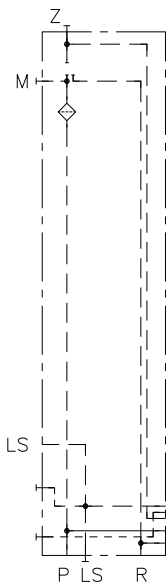

PSV 5.../...-5
PSV 6.../...-5
PSV UNF 6.../...-5
PSV JIS 5.../...-5

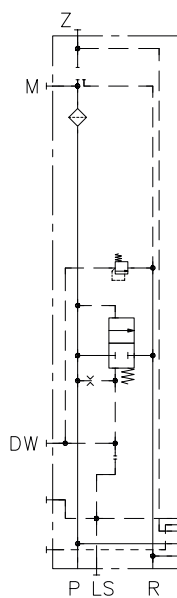

PSV 5 N.../.../...-5
PSV UNF 5 N.../.../...-5

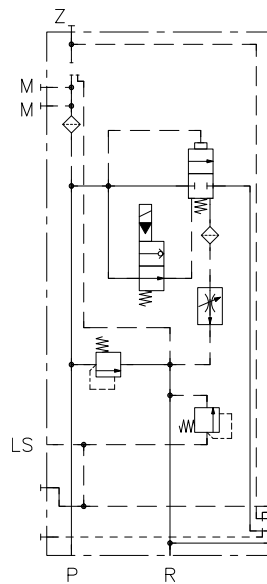

PSV 5 N...Z/.../...-5
PSV UNF 5N...Z/.../...-5

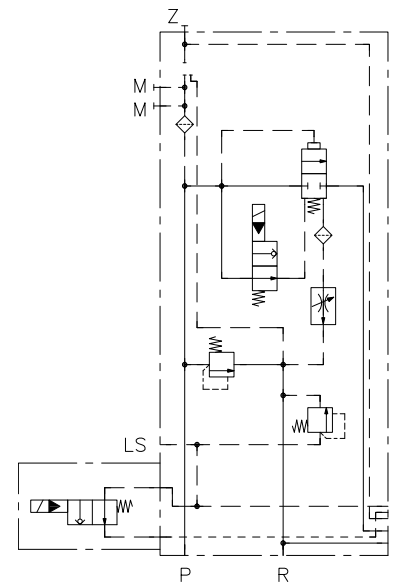

Schematic for PSL

PSM 5.../...-5
PSM 6.../...-5
PSM UNF 6.../...-5
PSM JIS 5.../...-5

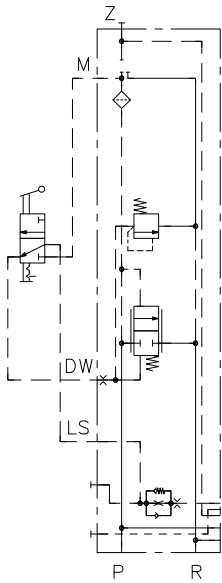

Schematic for constant pump system

Schematic for PSV

PSM 5.../...-5
PSM 6.../...-5
PSM UNF 6.../...-5
PSM JIS 5.../...-5

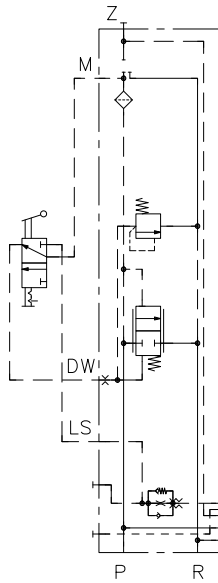

Schematic for variable pump system

2.1.5 Additional elements for 3-way controller

Coding	Description
without coding	Standard version 3-way controller with 9 bar circulation pressure
H	Special version 3-way controller with higher circulation pressure of 14 bar

2.1.6 LS damping elements

Coding	Description	Circuit symbol
without coding	<ul style="list-style-type: none"> For PSL and PSM: as for coding S For PSV: without LS damping 	
B	Ø 0.8 mm orifice	
B 4	Ø 0.4 / 0.5 / 0.6 / 0.7 mm orifice	
B 5		
B 6		
B 7		
B 55	Two Ø 0.5 mm orifices in series	
S	Pre-load and damper valve (pre-load pressure: 25 bar)	
W	Pre-load and damper valve with increased throttle effect (pre-load pressure: 25 bar)	
E	Damper valve without pre-load valve Because there is no pre-load valve, LS relief with all directional spool valves in neutral position occurs with a slight delay, system pressure drops only slowly. Common applications include consumers with a tendency to oscillate at low frequencies.	
G	Damper valve with increased throttle effect without pre-load valve Because there is no pre-load valve, LS relief with all directional spool valves in neutral position occurs with a slight delay, system pressure drops only slowly. Common applications include consumers with a tendency to oscillate at low frequencies.	

2.1.7 Internal control oil supply

Coding	Description	Circuit symbol
without coding	Without internal control oil supply For valve sections with manual, hydraulic or pneumatic actuation. Or for external control oil supply (required pilot pressure: 20 to 40 bar).	
1, 2	With internal control oil supply For valve sections with electro-hydraulic actuation. Optionally, a small quantity of control oil can be siphoned from the Z port to supply externally connected additional valves. In this case, the maximum permissible flow rate is 2 lpm. <ul style="list-style-type: none"> 1: 20 bar pilot pressure 2: 40 bar pilot pressure <div style="border: 1px solid black; padding: 5px; margin-top: 10px;"> <p>! NOTICE If multiple valve sections need to be actuated simultaneously, we recommend a pilot pressure of 40 bar.</p> </div>	

2.1.8 LS relief or LS pressure limitation

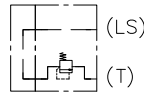
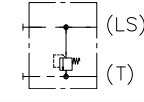
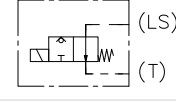
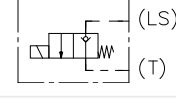
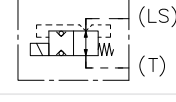
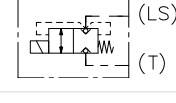
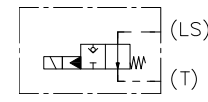
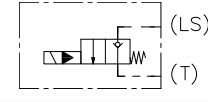
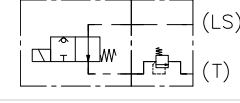
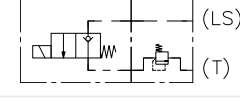
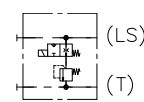
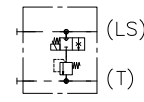
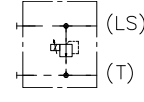
Coding	Description	Circuit symbol
without coding	Without LS relief or LS pressure limitation	 (LS) (T)
X...	LS pressure limitation (Adjustment range: 50 to 400 bar)	 (LS) (T)
VX...	LS pressure limitation (Adjustment range: 50 to 400 bar) Prepared for later conversion to coding ZD..., ZDM..., ZDP... or VD...	 (LS) (T)
F	LS relief, open when unpowered (WN 1 F as per D 7470 A/1)	 (LS) (T)
D	LS relief, closed when unpowered (WN 1 D as per D 7470 A/1)	 (LS) (T)
F BVE	LS relief, open when unpowered (BVE 1 R as per D 7921) When combined with solenoid version G 24 EX 55 FM, only approved for up to 250 bar.	 (LS) (T)
D BVE	LS relief, closed when unpowered (BVE 1 S as per D 7921) When combined with solenoid version G 24 EX 55 FM, only approved for up to 250 bar.	 (LS) (T)
ZA ZAM ZAP	LS relief, open when unpowered <ul style="list-style-type: none"> ▪ ZA: EM 11 S as per D 7490/1 ▪ ZAM: with wing bolt for mechanical locking (EM 11 S-...-M) ▪ ZAP: with button for manual override (EM 11 ST) 	 (LS) (T)
VA	LS relief, closed when unpowered (EM 11 V as per D 7490/1)	 (LS) (T)
F...	Switchable LS pressure limitation, active when unpowered (WN 1 F as per D 7470 A/1) (Adjustment range: 50 to 400 bar)	 (LS) (T)
D...	Switchable LS pressure limitation, disabled when unpowered (WN 1 D as per D 7470 A/1) (Adjustment range: 50 to 400 bar)	 (LS) (T)
ZD... ZDM... ZDP...	Switchable LS pressure limitation, active when unpowered. <ul style="list-style-type: none"> ▪ ZD...: EM 21 DS as per D 7490/1 E ▪ ZDM...: with wing bolt for mechanical locking (EM 21 DS-...-M) ▪ ZDP...: with button for manual override (EM 21 DST) 	 (LS) (T)
VD...	Switchable LS pressure limitation, disabled when unpowered (EM 21 D as per D 7490/1 E)	 (LS) (T)
PA PB PC PD	Proportional LS pressure limitation with ascending characteristic line Pressure ranges: <ul style="list-style-type: none"> ▪ PA: 35 to 320 bar ▪ PB: 25 to 210 bar ▪ PC: 40 to 400 bar ▪ PD: 50 to 420 bar 	 (LS) (T)

Coding	Description	Circuit symbol
Z ZM ZP	Proportional LS pressure limitation with ascending characteristic line <ul style="list-style-type: none"> Z: EM 21 DSE as per D 7490/1 E ZM: with wing bolt for mechanical locking (EM 21 DSE-...-M) ZP: with button for manual override (EM 21 DSET) 	(LS) (T)
V	Proportional LS pressure limitation with descending characteristic line (EM 21 DE as per D 7490/1 E)	(LS) (T)
X9 X18 X27	Intermediate plate for turning the downstream valve for LS relief or LS pressure limitation <ul style="list-style-type: none"> X9: Turns clockwise through 90° X18: Turns through 180° X27: Turns clockwise through 270° 	X9 (LS) (T) X18 (LS) (T) X27 (LS) (T)
Z ADM 0 Z ADM 3	Intermediate plate with copier valve for amplifying LS signal <ul style="list-style-type: none"> 0: without LS pressure amplification 3: with 3 bar LS pressure amplification <p>The M port of the copier valve is connected externally to the M port on the connection block. Optionally, additional LS damping is possible.</p> <p>The copier valve is designed as an intermediate plate. Port T and LS+ are usually sealed. If required, you can connect a release valve type F, D, F BVE or D BVE there (e.g. Z ADM 0/F BVE).</p>	Z ADM 0 (LS) (T) Z ADM 3 (LS) (T) Z ADM 0/F BVE (LS) (T)

NOTICE
LS relief valves and LS pressure-limiting valves of types X..., VX..., ZA, ZAM, ZAP, VA, F..., D..., ZD..., ZDM..., ZDP..., VD..., PA, PB, PC, PD, Z, ZM, ZP and V require the intake to be limited by means of LS damping, in order to ensure reliable release/pressure limitation, see Chapter 2.1.6, "LS damping elements"

NOTICE
If LS pressure-limiting valves of types PA, PB, PC, PD, Z, ZM, ZP, V are used for emergency stop functions, it is important to note that a certain residual pressure will always remain while the directional spool valve is shifted and there is a load pressure.

LS damping Coding	Residual pressure at load pressure of	
	250 bar	350 bar
B, S, W, E, G	125	150
B 7	100	120
B 6	85	95
B 5	75	80
B 4	60	70

see Chapter 2.1.6, "LS damping elements"

2.1.9 System pressure limitation

Coding	Description
without coding	Without pressure-limiting valve
/...	With pressure-limiting valve (adjustment range 50 to 420 bar)
/.../...	With pressure-limiting valve and LS pressure-limiting valve (only for PSV 5 N and PSV UNF 5 N) The first value is the setting for the main pressure-limiting valve, the second value is the setting for the LS pressure-limiting valve.

2.1.10 Size

Coding	Description
- 5	Size 5

For size 2 see [D 7700-2](#) and for size 3 see [D 7700-3](#)

2.1.11 Variants and potential combinations

PSL connection blocks

Type	P and R port as per ISO 228-1 or SAE J 514 or JIS B 2351	Max. recommended flow rate (lpm)	Pressure-limiting valve	
			direct actuation	pilot-controlled
PSL 5.../...-5	G 1	250		●
PSL 6.../...-5	G 1 1/4	300		●
PSL 5U.../...-5	G 1	250		●
PSL 6U.../...-5	G 1 1/4	300		●
PSL 6...UC22 2/...-5	G 1 1/4	300	●	
PSL 6Y.../...-5	G 1 1/4	300		●
PSL 6 UNF.../...-5	SAE-20 (1 5/8-12UN 2B)	300		●
PSL JIS 5.../...-5	JIS G 1	250		●

PSV connection blocks

Type	P and R port as per ISO 228-1 or SAE J 514 or JIS B 2351	Max. recommended flow rate (lpm)	Pressure-limiting valve		
			without	direct actuation	pilot-controlled
PSV 5...-5	G 1	250	●		
PSV 6...-5	G 1 1/4	300	●		
PSV 5.../...-5	G 1	250			●
PSV 6.../...-5	G 1 1/4	300			●
PSV 5 N.../.../...-5	G 1	300		●	
PSV UNF 6...-5	SAE-20 (1 5/8-12UN 2B)	300	●		
PSV UNF 6.../...-5	SAE-20 (1 5/8-12UN 2B)	300			●
PSV UNF 5 N.../.../ ...-5	SAE-16 (1 5/16-12 UN 2B)	300			
PSV JIS 5.../...-5	JIS G 1	250			●

PSM connection blocks

Type	P and R port as per ISO 228-1 or SAE J 514 or JIS B 2351	Max. recommended flow rate (lpm)	Pressure-limiting valve	
			direct actuation	pilot-controlled
PSM 5.../...-5	G 1	250		●
PSM 6.../...-5	G 1 1/4	300		●
PSM 6 UNF.../...-5	SAE-20 (1 5/8-12UN 2B)	300		●
PSM JIS 5.../...-5	JIS G 1	250		●

2.2 Valve section

A directional valve section is either available with integrated threads for the consumer ports A and B, or with a flange surface for mounting an ancillary block or an intermediate plate.

**Valve section
with integrated connection threads**

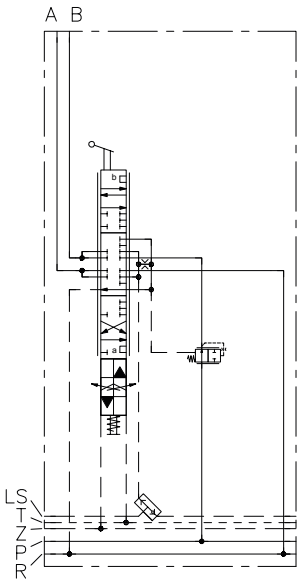

**Valve section
with ancillary block**

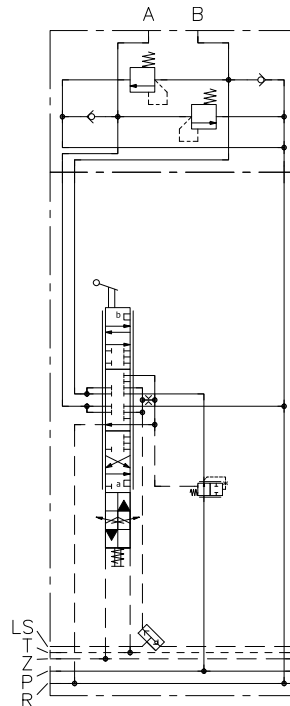

**Valve section
with intermediate plate and ancillary
block**

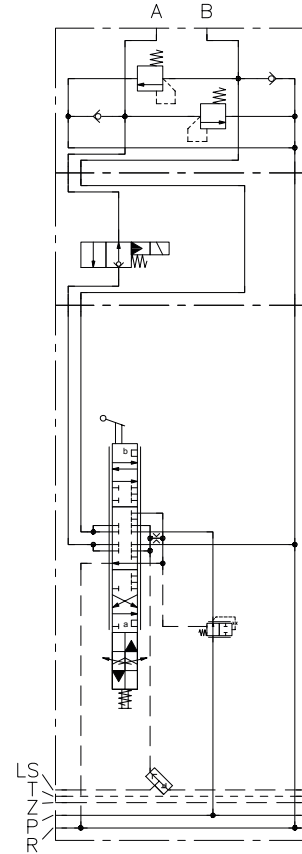

Depending on configuration, the directional valve sections incorporate:

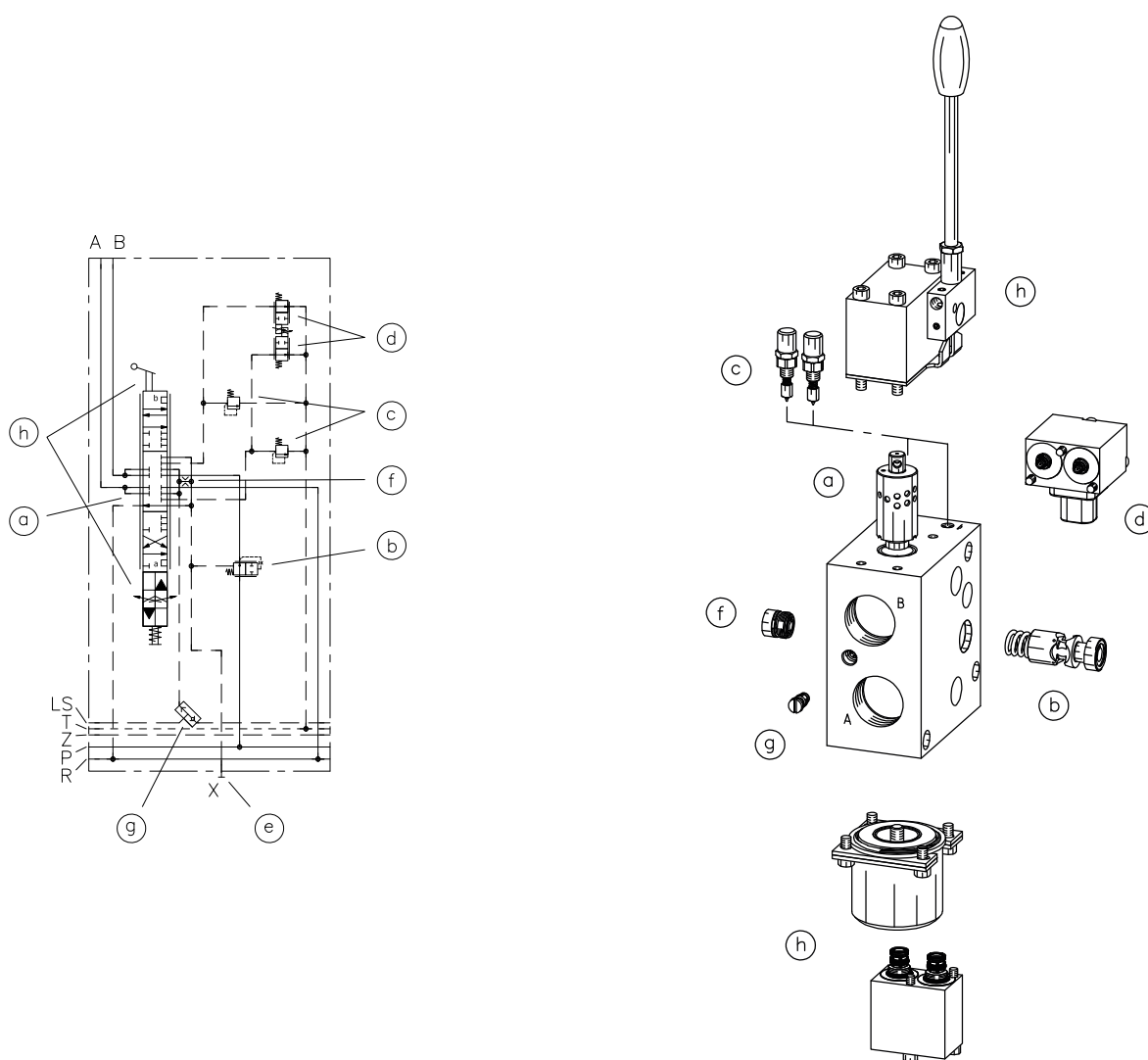

- a. A valve spool for controlling proportional flow rate
- b. A 2-way controller (pressure compensator) for controlling a constant pressure difference using the valve spool, irrespective of the current load pressure and pump pressure
- c. Fixed LS pressure-limiting valves
- d. Electric LS pressure-limiting valves for relief or electro-proportional limitation of the LS pressure
- e. Additional connections for external LS pressure limitation
- f. An LS orifice for damping the LS signal
- g. A shuttle valve for linking the LS line to additional valve sections
- h. An actuation for shifting the valve spool

Ordering example

SL 5	-A	R2	H160/160	A200 B300 F3 XXH	9	W3	/EA1	WA	Z ALW-250	/5
------	----	----	----------	------------------	---	----	------	----	-----------	----

2.2.1 "Consumer ports"

2-way controller

- 2.2 "Valve section"
- 2.2.1.3 "2-way controller spring"
- 2.2.1.4 "2-way controller damping"

Spool valve

- 2.2.1.5 "Circuit symbol"
- 2.2.1.6 "Flow rate"

LS pressure limitation

- 2.2.1.7 "LS pressure limitation"
- 2.2.1.8 "Electric LS relief or LS pressure limitation"
- 2.2.1.9 "LS port for external limitation"

2.2.1.10 "LS orifice"

2.2.1.11 "Shuttle valve"

Actuation

- 2.2.1.13 "Actuation"
- 2.2.1.14 "Additional elements for actuation"

2.2.1.15 "Switching position monitoring, displacement transducer"

2.2.3 "Intermediate plate (on the consumer side)"

2.2.2 "Ancillary block"

2.2.1 Directional valve section

2.2.1.1 Consumer ports

Coding	Description
A	Spool block without integrated thread for combining with an ancillary block (Chapter 2.2.2) or an intermediate plate (Chapter 2.2.3) and ancillary block
5	Consumer ports A and B in G 1 (ISO 228-1)
UNF 5	Consumer ports A and B in UNF SAE-16 or 1 5/16-12 UN 2B (SAE J 514)
	Only in conjunction with
	<ul style="list-style-type: none"> Actuation coding E... (Chapter 2.2.1.13) LS pressure limitation (Chapter 2.2.1.7) only in combination with LS relief or LS pressure limitation (Chapter 2.2.1.8)

! NOTICE

When combining a type PSL 5(6), PSV 5(6) and PSM 6 with a valve section with ancillary block (coding SL 5-A...), you will need to fit a 9 mm spacer plate (ZPL 55/9) behind the connection block to provide enough space for a spanner when installing the fitting on the R port.

2.2.1.2 Valve section, 2-way controller

Coding	Description	Circuit symbol
without coding	Standard 2-way controller	
1	Without 2-way controller	--
R	2-way controller with check valve function In the event of a shortage in supply, the controller prevents return flow from the load line (A or B-line) to the P-line. Only in conjunction with 2-way controller spring coding 2 and 5, see Chapter 2.2.1.3	
D	2-way controller with release of pressure The controller prevents pressure creep in the P-line between the 2-way controller and valve spool. Common applications include consumers with very low load pressures and without additional check valves. When using standard 2-way controllers, phantom movements may occur here. The D-controller can prevent this because the pressure is relieved towards T. In applications with check valves, the D-controller prevents undesired check valve intervention.	
I	Special controller with ascending characteristic line The controller has an inclined characteristic line. Flow rate increases with increasing differential pressure. <div style="text-align: center;"> <p>Q (l/min)</p> <p>Δp (bar)</p> <p>Q flow rate (lpm); Δp differential pressure (bar)</p> </div> Common applications include drives for tracked crawlers. In these, one side is always slightly ahead, its load pressure thus higher. The controller makes driving straight ahead easier by automatically accelerating the lagging side and neutralising the offset between the two sides.	

Coding	Description	Circuit symbol
8 81	<p>Pre-selector valve section without 2-way controller</p> <p>The pre-selector valve section shuts off the P-line in neutral position. Once the pre-selector valve activates, it supplies either the downstream valve sections (switching position b) or a second manifold connected to port A (switching position a).</p> <ul style="list-style-type: none"> 8: LS signal is signalled from port A (switching position a) and the downstream valve section (switching position b). Standard configuration if an Open Center valve is used on port A. 81: LS signal is only signalled by the downstream valve section (switching position b). Is used if a Closed Center LS valve is connected to port A; the LS signal is then usually signalled externally to the variable pump. <p>Common applications include loading cranes, concrete line pumps and lifting platforms. In these, the pre-selector valve is used to switch between operating the crane or mast and the outriggers. The pre-selector valve can further also be used as a P-line shut-off in safety functions.</p> <p>Only in conjunction with</p> <ul style="list-style-type: none"> PSL connection block with 3-way controller spring coding H (Chapter 2.1.5) or PSV connection block Circuit symbol L or H (Chapter 2.2.1.5) Actuation coding E... (Chapter 2.2.1.13) <div style="border: 1px solid black; padding: 5px; margin-top: 10px;"> <p>NOTICE</p> <p>When using a pre-selector valve, there is an additional pressure drop in the P-line that can lead to the downstream sections no longer reaching the nominal value.</p> <p>The undershooting of the nominal value depends on the</p> <ol style="list-style-type: none"> control pressure difference of the 3-way controller (PSL) or variable pump's pump controller (PSV), position of the valve section in the manifold and flow rate through the pre-selector valve or P-line shut-off. <p>The undershooting of the nominal value can reach up to 30% of Q_{nominal}, see "Flow rate".</p> </div> <p>This variant incorporates consumer port B, but it is sealed with a tapped plug. The UNF version does not have consumer port B.</p>	<p>• 8</p> <p>• 81</p>

2.2.1.3 2-way controller spring

Coding	Description
without coding	Without coding for configurations without 2-way controller (coding 1 or 8 Chapter 2.2.1.2)
2	Standard version (6 bar spring)
5	Heavy-duty version (9 bar spring) Only possible in conjunction with PSL connection block with 3-way controller spring coding H (2.1.5 "Additional elements for 3-way controller") or with PSV connection block
7	Heavy-duty version (13 bar spring) Only possible in conjunction with PSV connection block

2.2.1.4 2-way controller damping

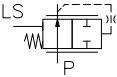
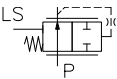
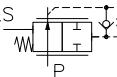
Coding	Description	Circuit symbol
without coding	Standard version without damping	
4 5 7	Special version with stronger damping. <ul style="list-style-type: none"> ▪ 4: Only in conjunction with standard 2-way controller (without coding) ▪ 5, 7: Only in conjunction with standard 2-way controller (without coding) and/or 2-way controller with check valve function (coding R) 	
S	Special version with closing damping Only in conjunction with standard 2-way controller (without coding) Common applications include hydraulic motors with a small number of pistons or with a low rotation speed. Here, the volume requested by the motor can be subject to oscillating changes if differing numbers of pistons in the motor are connected to the consumer at the PSL.	

2.2.1.5 Circuit symbol

Coding	Description	Circuit symbol			
L, M, F, H	Standard spool valve with low return pressure	L	M	F	H
J, B, R, O	Standard spool valve with constant return pressure of 20 bar Common applications: Stabilising cylinders with dragging loads, especially when used with load-holding valves or when used without additional check valves.	J	B	R	O
I, Y, Z, V	Standard spool valve with high reflux at < 1/3 spool valve shifting and rapid subsequent return pressure drop Common applications: Controlled deceleration of winches, slewing gear or other rotating consumers.	I	Y	Z	V

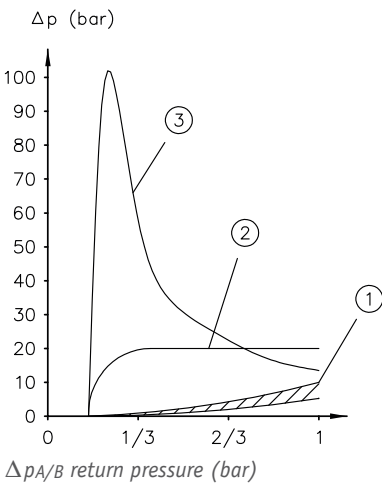



- 1 Circuit symbols L, M, F, H
- 2 Circuit symbols J, B, R, O
- 3 Circuit symbols I, Y, Z, V

NOTICE

The return pressure is in relation to the nominal flow rate. It may be higher or lower than shown in the diagram depending on the cylinder ratio or 2-way controller spring.

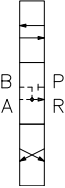
Coding	Description	Circuit symbol				
LW, MW, HW, JW, OW	Special version with broad fitting tolerance. <ul style="list-style-type: none"> ▪ Advantage: Reduces risk of jamming spool valve in systems prone to soiling. ▪ Drawback: higher spool valve leak rate 	LW	MW	HW	JW	OW

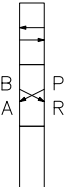
Coding	Description	Circuit symbol
LB	<p>Special version with minimal release of pressure from A and B-line when spool valve in idle position.</p> <p>Common applications: Combined with load-holding valves that require closed spool valve in neutral position in line with safety requirements. The LB spool valve in such a case prevents trapping pressure between spool valve and load-holding valve and allows the load-holding valve to close reliably.</p>	<p>LB</p> 
G	<p>3/3-way directional spool valve for single-acting cylinders</p> <p>The G spool valve can be combined with any valve section, port B is sealed with a tapped plug when doing so.</p> <p>No LS signal is produced when load drops. If used in conjunction with electro-hydraulic actuation and a PSL connection block with standard 3-way controller spring, this can result in the internally generated pilot pressure not being sufficient to fully shift the spool valve, see Chapter 2.1.5, "Additional elements for 3-way controller".</p> <p>Load reduction is throttled using the spool valve's meter-out edge. If desired, the maximum reduction rate can be capped using a separate flow control valve (e.g. type SB as per D 6920).</p>	<p>G</p> 
W	<p>Special spool valve in conjunction with P → A in neutral position</p> <p>Common applications: Fan drives, generator drives or other consumers requiring a specific flow rate when unpowered for safety reasons.</p> <ul style="list-style-type: none"> ▪ W: 4/2-way directional spool valve In neutral position, the maximum flow rate is towards A-side. By shifting the spool valve to switching position b, the direction is reversed and the flow rate is towards B-side. Decelerating consumer to zero as well as proportional flow rate control are only possible to a limited degree. This makes the W spool valve suitable primarily for applications with constant speed. <p>Available versions:</p> <ul style="list-style-type: none"> ▪ W 120/120 	<p>W</p> 



NOTICE

For instructions on how to replace the valve spool, see Chapter 5.2.4, "Changing the valve spool".



NOTICE

If the nature of the application means the reflux is not directed through the valve section to the tank, please observe Chapter 5.2.2.1, "Reflux piping routed externally to the tank".

2.2.1.6 Flow rate

Coding 2-way controller spring, see Chapter 2.2.1.3	Coding for flow rate (Q_{nominal} in lpm) With maximum spool valve actuation						
	16	25	40	63	80	120	160
2	16	25	40	63	80	120	160
5	20	32	51	80	110	150	210
7	23	37	60	95	130	175	240

NOTICE

The return pressure is in relation to the nominal flow rate. It may be higher or lower than shown in the diagram depending on the cylinder ratio or 2-way controller spring.

Flow rate for coding 1 and 8

On valve sections without a 2-way controller (coding 1 or 8 for Q_A , see Chapter 2.2.1.2, "Valve section, 2-way controller"), it is possible to calculate the flow rate using the following formula:

$$Q_{A/B} = Q_{\text{Nenn}} \cdot \sqrt{0,2 \cdot \Delta p_{\text{Regler}}}$$

$Q_{A/B}$ = flow rate to port A or B

Q_{nominal} = Nominal flow rate of valve spool at pressure difference of 6 bar

$\Delta p_{\text{controller}}$ = control pressure difference of the 3-way controller (PSL) or of the variable pump's pump controller (PSV)

Example:

- PSL connection block, standard 3-way controller spring (9 bar)
 $Q_{A/B} = 120 \text{ l/min} \cdot \sqrt{0,2 \cdot 9} = 161 \text{ l/min}$
- PSL connection block, 3-way controller with heavy-duty spring (14 bar)
 $Q_{A/B} = 120 \text{ l/min} \cdot \sqrt{0,2 \cdot 14} = 201 \text{ l/min}$
- PSV connection block, pump controller with 25 bar standby pressure
 $Q_{A/B} = 120 \text{ l/min} \cdot \sqrt{0,2 \cdot 25} = 268 \text{ l/min}$

NOTICE

The calculated values are rough reference values!
They apply only to the highest-load consumer. If multiple consumers are being actuated in parallel, the pressure difference may be considerably greater at the lower-load consumers.

NOTICE

When using a pre-selector valve (coding 8, see Chapter 2.2.1.2, "Valve section, 2-way controller") or a P-line shut-off (coding PSV 5 N or PSV UNF 5 N, see Chapter 2.1.2, "Basic version"), there is an additional pressure drop in the P-line that can lead to the downstream sections no longer reaching the nominal value.

Flow rate coding

Spool valves are defined using two flow rate codings in the order coding. The first number indicates nominal flow rate on the A-side (Q_A) and the second number indicates nominal flow rate on the B-side (Q_B). The shape of the spool valve's two outflow edges is defined by the circuit symbol, see Chapter 2.2.1.5, "Circuit symbol".

- **Ordering example:** L 120/80, J 80/63, H 160/160, O 120/120

Flow rate setting value

If the desired flow rate lies between two flow rate codings, the desired setting value can be specified separately in brackets.

The maximum flow rate is then limited to this value by the stroke limitation of the actuation, see Chapter 2.2.1.13, "Actuation"

Not possible in conjunction with CAN actuation, see Chapter 2.2.1.13, "Actuation".

- **Ordering example 1:** SL 5-A2 L 120/120/EA (90/110)

Setting values: A – 90 lpm
 B – 110 lpm

- **Ordering example 2:** SL 5-A2 L 120/120/EA (90/max)

Setting values: A – 90 lpm
 B – no stroke limitation

- **Ordering example 3:** SL 5-A2 L 120/120/EA (90/120)

Setting values: A – 90 lpm
 B – 120 lpm

NOTICE

The valve spools' sizes are designed to make actual flow rate slightly higher than Q_{nominal} in practice. You can use stroke limitation to limit the maximum flow rate.

Flow rate coding with larger or smaller outflow edges

For J and O spool valves, the outflow edge can also be customised. In such a case, the order coding has 4 digits and looks like this: $Q_{A \rightarrow R} - Q_{P \rightarrow A} / Q_{P \rightarrow B} - Q_{B \rightarrow R}$. Choosing a smaller key figure increases return pressure. A larger key figure reduces return pressure.

► **Ordering example:** J 120-120/160-80, O 25-80/40-63

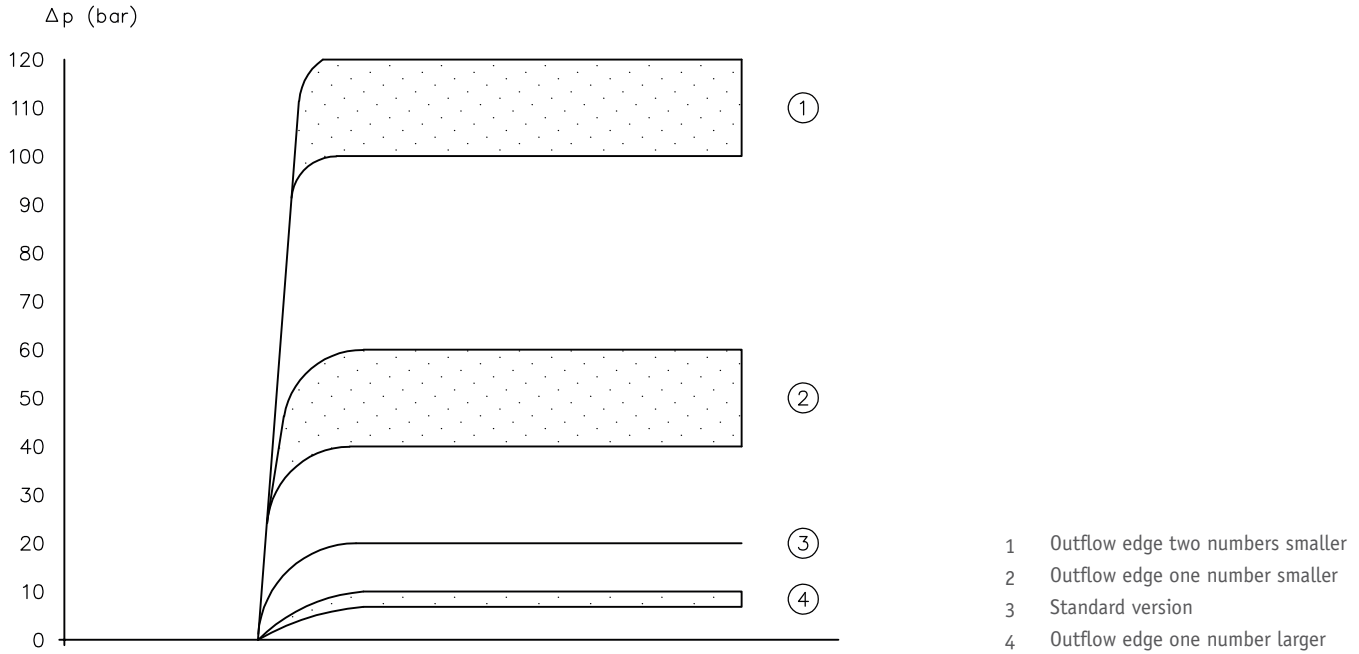

- 1 Outflow edge two numbers smaller
- 2 Outflow edge one number smaller
- 3 Standard version
- 4 Outflow edge one number larger

NOTICE

The return pressure is in relation to the nominal flow rate. It may be higher or lower than shown in the diagram depending on the cylinder ratio or 2-way controller spring.

2.2.1.7 LS pressure limitation

Coding	Description	View
without coding	Without LS pressure limitation Without LS pressure limitation	
AB	Without LS pressure limitation, but prepared for later conversion to coding A.., B.. or A.. B..	
A..	LS pressure limitation for A-side (Adjustment range: 50 to 400 bar)	
B..	LS pressure limitation for B-side (Adjustment range: 50 to 400 bar)	
A.. B..	LS pressure limitation for A and B-side with two separate pressure settings (Adjustment range: 50 to 400 bar)	
C..	LS pressure limitation for A and B-side with a single shared pressure setting for both sides (Adjustment range: 50 to 400 bar)	
<p>Only in conjunction with</p> <ul style="list-style-type: none"> Consumer port (Chapter 2.2.1.1) coding 5 and actuation (Chapter 2.2.1.13) coding E... or A... Consumer port – consumer port (Chapter 2.2.1.1) coding A and actuation (Chapter 2.2.1.13) coding E... 		

Circuit symbols

without coding

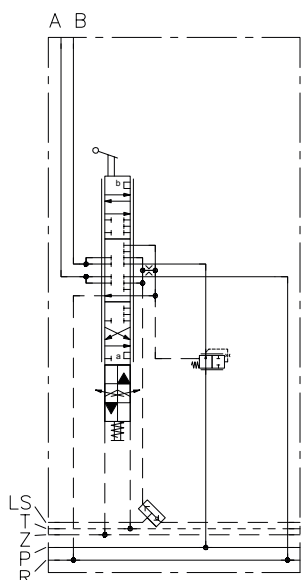

AB

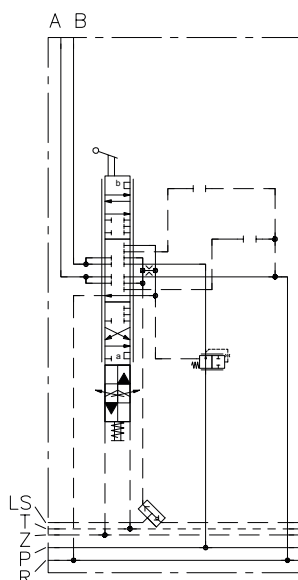

A..

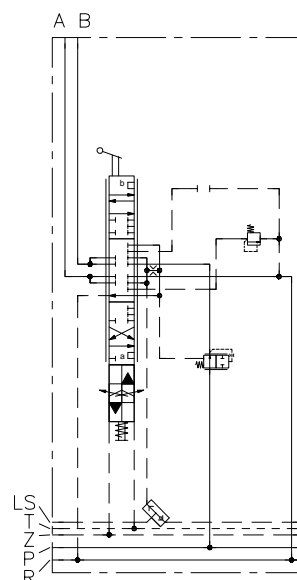

B..

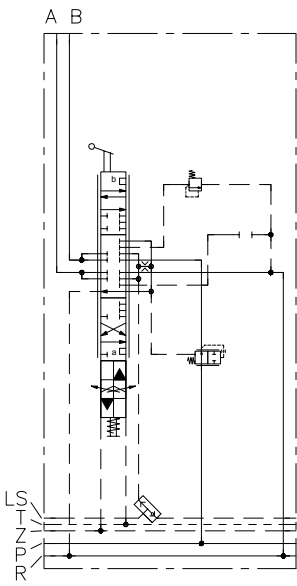

A.. B..

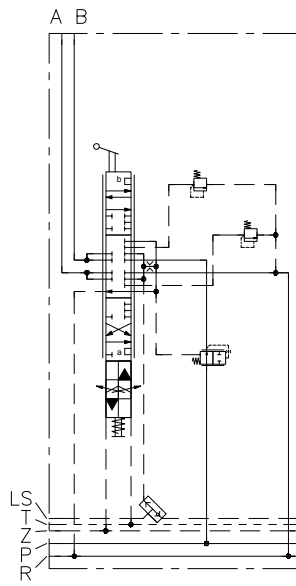

C..

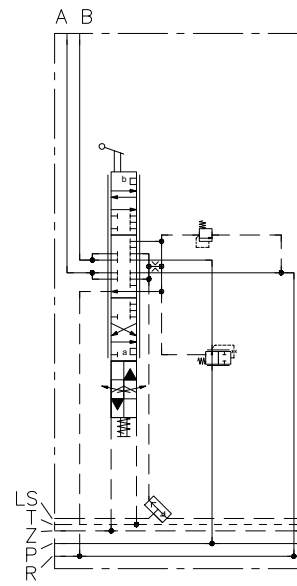

NOTICE

LS pressure limitation is only available in conjunction with a 2-way controller ([Chapter 2.2.1.2](#)).

2.2.1.8 Electric LS relief or LS pressure limitation

Coding	Description																												
without coding	Without electric LS relief or LS pressure limitation																												
F 0	<p>Without electric LS relief or LS pressure limitation, but prepared for later conversion to coding F, FH, FP, FPH.</p> <p>Only in conjunction with:</p> <table border="1"> <thead> <tr> <th>Consumer ports (Chapter 2.2.1.1)</th> <th>LS pressure limitation (Chapter 2.2.1.7)</th> <th>LS port for external limitation (Chapter 2.2.1.9)</th> <th>Actuation (Chapter 2.2.1.13)</th> </tr> </thead> <tbody> <tr> <td rowspan="3">SL 5-5..</td> <td>AB, A..B., A., B..</td> <td></td> <td>with E</td> </tr> <tr> <td>AB, A..B., A., B..</td> <td></td> <td>without E</td> </tr> <tr> <td>AB, A..B., A., B..</td> <td>X</td> <td>with E</td> </tr> <tr> <td rowspan="3">SL 5-A..</td> <td>AB, A..B., A., B..</td> <td></td> <td>with E</td> </tr> <tr> <td></td> <td></td> <td>with E</td> </tr> <tr> <td>AB, A..B., A., B..</td> <td>XXH</td> <td>with E</td> </tr> <tr> <td>SL 5-UNF 5..</td> <td>AB, A..B., A., B..</td> <td></td> <td>with E</td> </tr> </tbody> </table>	Consumer ports (Chapter 2.2.1.1)	LS pressure limitation (Chapter 2.2.1.7)	LS port for external limitation (Chapter 2.2.1.9)	Actuation (Chapter 2.2.1.13)	SL 5-5..	AB, A..B., A., B..		with E	AB, A..B., A., B..		without E	AB, A..B., A., B..	X	with E	SL 5-A..	AB, A..B., A., B..		with E			with E	AB, A..B., A., B..	XXH	with E	SL 5-UNF 5..	AB, A..B., A., B..		with E
Consumer ports (Chapter 2.2.1.1)	LS pressure limitation (Chapter 2.2.1.7)	LS port for external limitation (Chapter 2.2.1.9)	Actuation (Chapter 2.2.1.13)																										
SL 5-5..	AB, A..B., A., B..		with E																										
	AB, A..B., A., B..		without E																										
	AB, A..B., A., B..	X	with E																										
SL 5-A..	AB, A..B., A., B..		with E																										
			with E																										
	AB, A..B., A., B..	XXH	with E																										
SL 5-UNF 5..	AB, A..B., A., B..		with E																										
F 1, F 2, F 3 FH 1, FH 2, FH 3	<p>Electric LS relief (function deactivation) LS signal without load when unpowered.</p> <ul style="list-style-type: none"> ▪ F1: A-side only ▪ F2: B-side only ▪ F3: A and B-side separate ▪ FH 1, FH 2, FH 3: additionally with button for manual override <p>Only in conjunction with:</p> <table border="1"> <thead> <tr> <th>Consumer ports (Chapter 2.2.1.1)</th> <th>LS pressure limitation (Chapter 2.2.1.7)</th> <th>LS port for external limitation (Chapter 2.2.1.9)</th> <th>Actuation (Chapter 2.2.1.13)</th> </tr> </thead> <tbody> <tr> <td rowspan="3">SL 5-5..</td> <td>AB, A..B., A., B..</td> <td></td> <td>with E</td> </tr> <tr> <td>AB, A..B., A., B..</td> <td></td> <td>without E</td> </tr> <tr> <td>AB, A..B., A., B..</td> <td>X</td> <td>with E</td> </tr> <tr> <td rowspan="3">SL 5-A..</td> <td>AB, A..B., A., B..</td> <td></td> <td>with E</td> </tr> <tr> <td></td> <td></td> <td>with E</td> </tr> <tr> <td>AB, A..B., A., B..</td> <td>XXH</td> <td>with E</td> </tr> <tr> <td>SL 5-UNF 5..</td> <td>AB, A..B., A., B..</td> <td></td> <td>with E</td> </tr> </tbody> </table>	Consumer ports (Chapter 2.2.1.1)	LS pressure limitation (Chapter 2.2.1.7)	LS port for external limitation (Chapter 2.2.1.9)	Actuation (Chapter 2.2.1.13)	SL 5-5..	AB, A..B., A., B..		with E	AB, A..B., A., B..		without E	AB, A..B., A., B..	X	with E	SL 5-A..	AB, A..B., A., B..		with E			with E	AB, A..B., A., B..	XXH	with E	SL 5-UNF 5..	AB, A..B., A., B..		with E
Consumer ports (Chapter 2.2.1.1)	LS pressure limitation (Chapter 2.2.1.7)	LS port for external limitation (Chapter 2.2.1.9)	Actuation (Chapter 2.2.1.13)																										
SL 5-5..	AB, A..B., A., B..		with E																										
	AB, A..B., A., B..		without E																										
	AB, A..B., A., B..	X	with E																										
SL 5-A..	AB, A..B., A., B..		with E																										
			with E																										
	AB, A..B., A., B..	XXH	with E																										
SL 5-UNF 5..	AB, A..B., A., B..		with E																										

Coding	Description																												
FP.. FPH..	<p>Electro-proportional LS pressure limitation with ascending characteristic line</p> <p>Pressure ranges for A and for B-side: (with 2-way controller spring coding 2 as per Chapter 2.2.1.2)</p> <ul style="list-style-type: none"> ▪ 0 = sealed ▪ 1 = 20 to 150 bar ▪ 2 = 25 to 210 bar ▪ 3 = 35 to 320 bar ▪ 5 = 40 to 400 bar ▪ 7 = 50 to 420 bar <p>The first number applies to A-side. The second number applies to B-side.</p> <p>Ordering example: FP53</p> <ul style="list-style-type: none"> ▪ FPH..: additionally with button for manual override <p>Only in conjunction with:</p> <table border="1" style="width: 100%; border-collapse: collapse;"> <thead> <tr> <th style="width: 25%;">Consumer ports (Chapter 2.2.1.1)</th> <th style="width: 25%;">LS pressure limitation (Chapter 2.2.1.7)</th> <th style="width: 25%;">LS port for external limitation (Chapter 2.2.1.9)</th> <th style="width: 25%;">Actuation (Chapter 2.2.1.13)</th> </tr> </thead> <tbody> <tr> <td rowspan="3">SL 5-5..</td> <td>AB, A..B.., A.., B..</td> <td></td> <td>with E</td> </tr> <tr> <td>AB, A..B.., A.., B..</td> <td></td> <td>without E</td> </tr> <tr> <td>AB, A..B.., A.., B..</td> <td>X</td> <td>with E</td> </tr> <tr> <td rowspan="3">SL 5-A..</td> <td>AB, A..B.., A.., B..</td> <td></td> <td>with E</td> </tr> <tr> <td></td> <td></td> <td>with E</td> </tr> <tr> <td>AB, A..B.., A.., B..</td> <td>XXH</td> <td>with E</td> </tr> <tr> <td>SL 5-UNF 5..</td> <td>AB, A..B.., A.., B..</td> <td></td> <td>with E</td> </tr> </tbody> </table>	Consumer ports (Chapter 2.2.1.1)	LS pressure limitation (Chapter 2.2.1.7)	LS port for external limitation (Chapter 2.2.1.9)	Actuation (Chapter 2.2.1.13)	SL 5-5..	AB, A..B.., A.., B..		with E	AB, A..B.., A.., B..		without E	AB, A..B.., A.., B..	X	with E	SL 5-A..	AB, A..B.., A.., B..		with E			with E	AB, A..B.., A.., B..	XXH	with E	SL 5-UNF 5..	AB, A..B.., A.., B..		with E
Consumer ports (Chapter 2.2.1.1)	LS pressure limitation (Chapter 2.2.1.7)	LS port for external limitation (Chapter 2.2.1.9)	Actuation (Chapter 2.2.1.13)																										
SL 5-5..	AB, A..B.., A.., B..		with E																										
	AB, A..B.., A.., B..		without E																										
	AB, A..B.., A.., B..	X	with E																										
SL 5-A..	AB, A..B.., A.., B..		with E																										
			with E																										
	AB, A..B.., A.., B..	XXH	with E																										
SL 5-UNF 5..	AB, A..B.., A.., B..		with E																										
FPC-S.. FPC-R../..	<p>Electro-proportional LS pressure limitation with ascending characteristic line. Limits the pressure for A and B-side. Different pressure values in A and B are controlled electrically.</p> <ul style="list-style-type: none"> ▪ FPC-S..: <ul style="list-style-type: none"> – ascending characteristic line / normally open (PMVE 1 S... according to D 8143) ▪ FPC-R../..: <ul style="list-style-type: none"> – falling characteristic line / normally closed (PMVE 1 R according to D 8143) – with additional mechanical p_{max} setting (75 – 100 % from pressure range) <p>Pressure stage</p> <ul style="list-style-type: none"> ▪ A = up to 50 bar ▪ B = up to 100 bar ▪ C = up to 150 bar ▪ D = up to 200 bar ▪ E = up to 250 bar ▪ F = up to 300 bar ▪ G = up to 350 bar ▪ H = up to 420 bar <p>Only in conjunction with:</p> <table border="1" style="width: 100%; border-collapse: collapse;"> <thead> <tr> <th style="width: 25%;">Consumer ports (Chapter 2.2.1.1)</th> <th style="width: 25%;">LS pressure limitation (Chapter 2.2.1.7)</th> <th style="width: 25%;">Actuation (Chapter 2.2.1.13)</th> </tr> </thead> <tbody> <tr> <td>SL 5-5..</td> <td>AB, A..B.., A.., B..</td> <td>with E</td> </tr> <tr> <td>SL 5-A..</td> <td>AB, A..B.., A.., B..</td> <td>with E</td> </tr> <tr> <td>SL 5-UNF 5..</td> <td>AB, A..B.., A.., B..</td> <td>with E</td> </tr> </tbody> </table>	Consumer ports (Chapter 2.2.1.1)	LS pressure limitation (Chapter 2.2.1.7)	Actuation (Chapter 2.2.1.13)	SL 5-5..	AB, A..B.., A.., B..	with E	SL 5-A..	AB, A..B.., A.., B..	with E	SL 5-UNF 5..	AB, A..B.., A.., B..	with E																
Consumer ports (Chapter 2.2.1.1)	LS pressure limitation (Chapter 2.2.1.7)	Actuation (Chapter 2.2.1.13)																											
SL 5-5..	AB, A..B.., A.., B..	with E																											
SL 5-A..	AB, A..B.., A.., B..	with E																											
SL 5-UNF 5..	AB, A..B.., A.., B..	with E																											

Coding	Description												
FPCX	Prepared for electro-proportional LS release of pressure FPC-S.. and FPC-R..												
	Only in conjunction with:												
	<table border="1" style="width: 100%; border-collapse: collapse;"> <thead> <tr> <th style="width: 33%;">Consumer ports (Chapter 2.2.1.1)</th> <th style="width: 33%;">LS pressure limitation (Chapter 2.2.1.7)</th> <th style="width: 33%;">Actuation (Chapter 2.2.1.13)</th> </tr> </thead> <tbody> <tr> <td>SL 5-5..</td> <td>AB, A..B.., A.., B..</td> <td>with E</td> </tr> <tr> <td>SL 5-A..</td> <td>AB, A..B.., A.., B..</td> <td>with E</td> </tr> <tr> <td>SL 5-UNF 5..</td> <td>AB, A..B.., A.., B..</td> <td>with E</td> </tr> </tbody> </table>	Consumer ports (Chapter 2.2.1.1)	LS pressure limitation (Chapter 2.2.1.7)	Actuation (Chapter 2.2.1.13)	SL 5-5..	AB, A..B.., A.., B..	with E	SL 5-A..	AB, A..B.., A.., B..	with E	SL 5-UNF 5..	AB, A..B.., A.., B..	with E
Consumer ports (Chapter 2.2.1.1)	LS pressure limitation (Chapter 2.2.1.7)	Actuation (Chapter 2.2.1.13)											
SL 5-5..	AB, A..B.., A.., B..	with E											
SL 5-A..	AB, A..B.., A.., B..	with E											
SL 5-UNF 5..	AB, A..B.., A.., B..	with E											

Circuit symbols

without coding

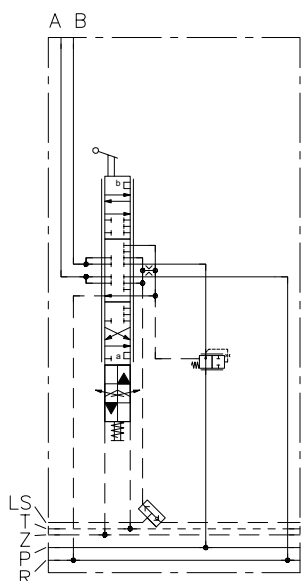

F 0

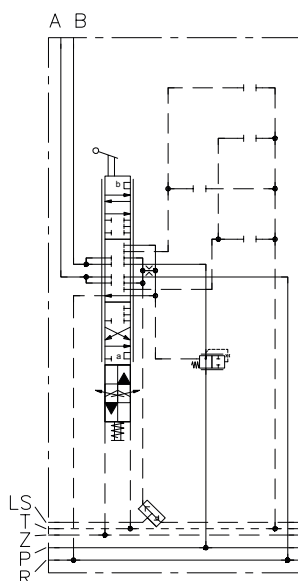

F 1, FH 1

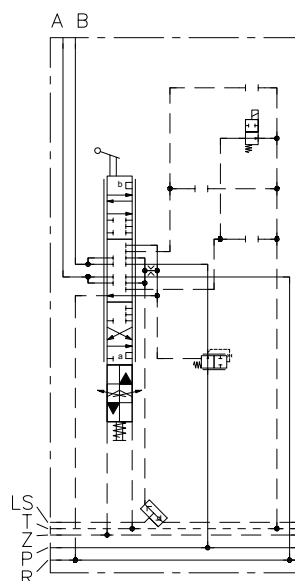

F 2, FH 2

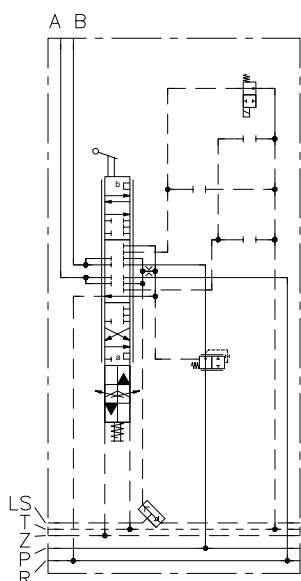

F 3, FH 3

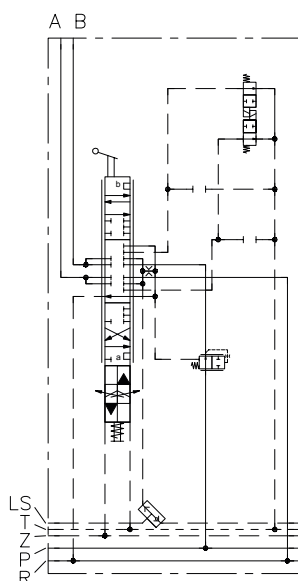

FP., FPH..

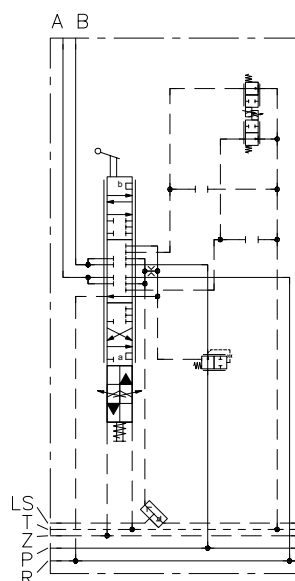

FPC-S..

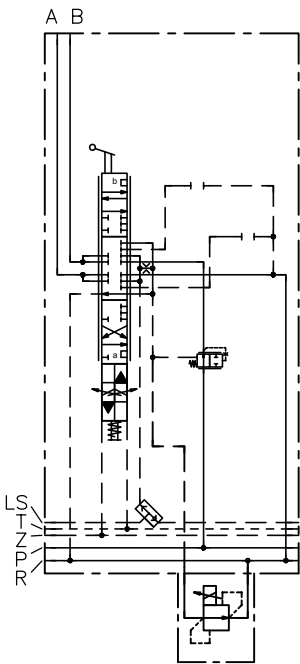

FPC-R../..

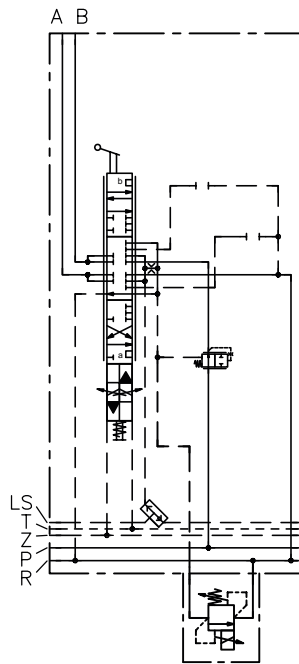

FPCX

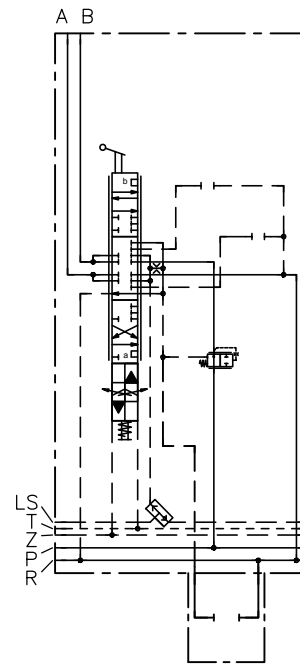

! NOTICE

Electric LS relief or LS pressure limitation is only available in conjunction with a 2-way controller ([Chapter 2.2.1.2](#)).

! NOTICE

Even with LS relief, pressure in consumer channel A or B cannot be reduced completely to 0 bar. The residual pressure in A or B ($p_{\min, A/B}$) results from

- a) control pressure in the 2-way controller ($\Delta p_{2\text{-way controller}}$),
- b) internal dynamic pressure in block (Δp_{Block}) and
- c) return pressure (p_{reflux}).

$$p_{\min, A/B} = \Delta p_{2\text{-way controller}} + \Delta p_{\text{Block}} + p_{\text{reflux}}$$

$\Delta p_{2\text{-way controller}}$: see [Chapter 2.2.1.2](#)

$\Delta p_{\text{Block}} = 10 \text{ bar}$ for coding F 1, F 2, F 3, FH 1, FH 2, FH 3

2.2.1.9 LS port for external limitation

Coding	Description																												
without coding	Without LS port for external limitation																												
S1 S1 UNF	<p>Ports for an external pilot valve.</p> <ul style="list-style-type: none"> U port = LSA W port = LSB <p>Connection thread:</p> <ul style="list-style-type: none"> S1: G 1/8 (ISO 228-1) S1 UNF: SAE-4 or 7/16-20 UNF-2B (SAE J 514) <p>Only in conjunction with:</p> <table border="1"> <thead> <tr> <th>Consumer ports (Chapter 2.2.1.1)</th> <th>LS pressure limitation (Chapter 2.2.1.7)</th> <th>LS port for external limitation (Chapter 2.2.1.9)</th> <th>Actuation (Chapter 2.2.1.13)</th> </tr> </thead> <tbody> <tr> <td rowspan="3">SL 5-5..</td> <td>AB, A..B.., A.., B..</td> <td></td> <td>with E</td> </tr> <tr> <td>AB, A..B.., A.., B..</td> <td></td> <td>without E</td> </tr> <tr> <td>AB, A..B.., A.., B..</td> <td>X</td> <td>with E</td> </tr> <tr> <td rowspan="3">SL 5-A..</td> <td>AB, A..B.., A.., B..</td> <td></td> <td>with E</td> </tr> <tr> <td></td> <td></td> <td>with E</td> </tr> <tr> <td>AB, A..B.., A.., B..</td> <td>XXH</td> <td>with E</td> </tr> <tr> <td>SL 5-UNF 5..</td> <td>AB, A..B.., A.., B..</td> <td></td> <td>with E</td> </tr> </tbody> </table>	Consumer ports (Chapter 2.2.1.1)	LS pressure limitation (Chapter 2.2.1.7)	LS port for external limitation (Chapter 2.2.1.9)	Actuation (Chapter 2.2.1.13)	SL 5-5..	AB, A..B.., A.., B..		with E	AB, A..B.., A.., B..		without E	AB, A..B.., A.., B..	X	with E	SL 5-A..	AB, A..B.., A.., B..		with E			with E	AB, A..B.., A.., B..	XXH	with E	SL 5-UNF 5..	AB, A..B.., A.., B..		with E
Consumer ports (Chapter 2.2.1.1)	LS pressure limitation (Chapter 2.2.1.7)	LS port for external limitation (Chapter 2.2.1.9)	Actuation (Chapter 2.2.1.13)																										
SL 5-5..	AB, A..B.., A.., B..		with E																										
	AB, A..B.., A.., B..		without E																										
	AB, A..B.., A.., B..	X	with E																										
SL 5-A..	AB, A..B.., A.., B..		with E																										
			with E																										
	AB, A..B.., A.., B..	XXH	with E																										
SL 5-UNF 5..	AB, A..B.., A.., B..		with E																										
S	<p>Ports for an external pilot valve.</p> <ul style="list-style-type: none"> U port = LSA W port = LSB <p>The ports are integrated directly in the spool block.</p> <p>Connection thread:</p> <ul style="list-style-type: none"> G 1/8 (ISO 228-1) <p>Only in conjunction with:</p> <table border="1"> <thead> <tr> <th>Consumer ports (Chapter 2.2.1.1)</th> <th>LS pressure limitation (Chapter 2.2.1.7)</th> <th>Actuation (Chapter 2.2.1.13)</th> </tr> </thead> <tbody> <tr> <td rowspan="3">SL 5-5..</td> <td>AB, A..B.., A.., B..</td> <td>with E</td> </tr> <tr> <td></td> <td>with E</td> </tr> <tr> <td>AB, A..B.., A.., B..</td> <td>without E</td> </tr> <tr> <td></td> <td></td> <td>without E</td> </tr> </tbody> </table>	Consumer ports (Chapter 2.2.1.1)	LS pressure limitation (Chapter 2.2.1.7)	Actuation (Chapter 2.2.1.13)	SL 5-5..	AB, A..B.., A.., B..	with E		with E	AB, A..B.., A.., B..	without E			without E															
Consumer ports (Chapter 2.2.1.1)	LS pressure limitation (Chapter 2.2.1.7)	Actuation (Chapter 2.2.1.13)																											
SL 5-5..	AB, A..B.., A.., B..	with E																											
		with E																											
	AB, A..B.., A.., B..	without E																											
		without E																											
X	<p>Port for an external pilot valve.</p> <ul style="list-style-type: none"> X port = LSA/B <p>The port is integrated directly in the spool block.</p> <p>Connection thread:</p> <ul style="list-style-type: none"> G 1/8 (ISO 228-1) <p>Only in conjunction with:</p> <table border="1"> <thead> <tr> <th>Consumer ports (Chapter 2.2.1.1)</th> <th>LS pressure limitation (Chapter 2.2.1.7)</th> <th>LS relief or LS pressure limitation (Chapter 2.2.1.8)</th> <th>Actuation (Chapter 2.2.1.13)</th> </tr> </thead> <tbody> <tr> <td rowspan="2">SL 5-5..</td> <td>AB, A..B.., A.., B..</td> <td>F..</td> <td>with E</td> </tr> <tr> <td>C..</td> <td></td> <td>with E</td> </tr> </tbody> </table>	Consumer ports (Chapter 2.2.1.1)	LS pressure limitation (Chapter 2.2.1.7)	LS relief or LS pressure limitation (Chapter 2.2.1.8)	Actuation (Chapter 2.2.1.13)	SL 5-5..	AB, A..B.., A.., B..	F..	with E	C..		with E																	
Consumer ports (Chapter 2.2.1.1)	LS pressure limitation (Chapter 2.2.1.7)	LS relief or LS pressure limitation (Chapter 2.2.1.8)	Actuation (Chapter 2.2.1.13)																										
SL 5-5..	AB, A..B.., A.., B..	F..	with E																										
	C..		with E																										

Coding

Description

XXH

Ports for an external pilot valve.

- X port = LS_{A/B}
- XH port = LS_{A/B}

Unlike with coding X, in the case of XH the LS signal pick-up is upstream of the LS orifice. This makes a greater flow rate available for auxiliary functions (e.g. releasing a brake).

The port is integrated directly in the spool block.

Connection thread:

- G 1/8 (ISO 228-1)

Only in conjunction with:

Consumer ports (Chapter 2.2.1.1)	LS pressure limitation (Chapter 2.2.1.7)	LS relief or LS pressure limitation (Chapter 2.2.1.8)	Actuation (Chapter 2.2.1.13)
SL 5-A..	AB, A..B.., A.., B..	F..	with E

Circuit symbols

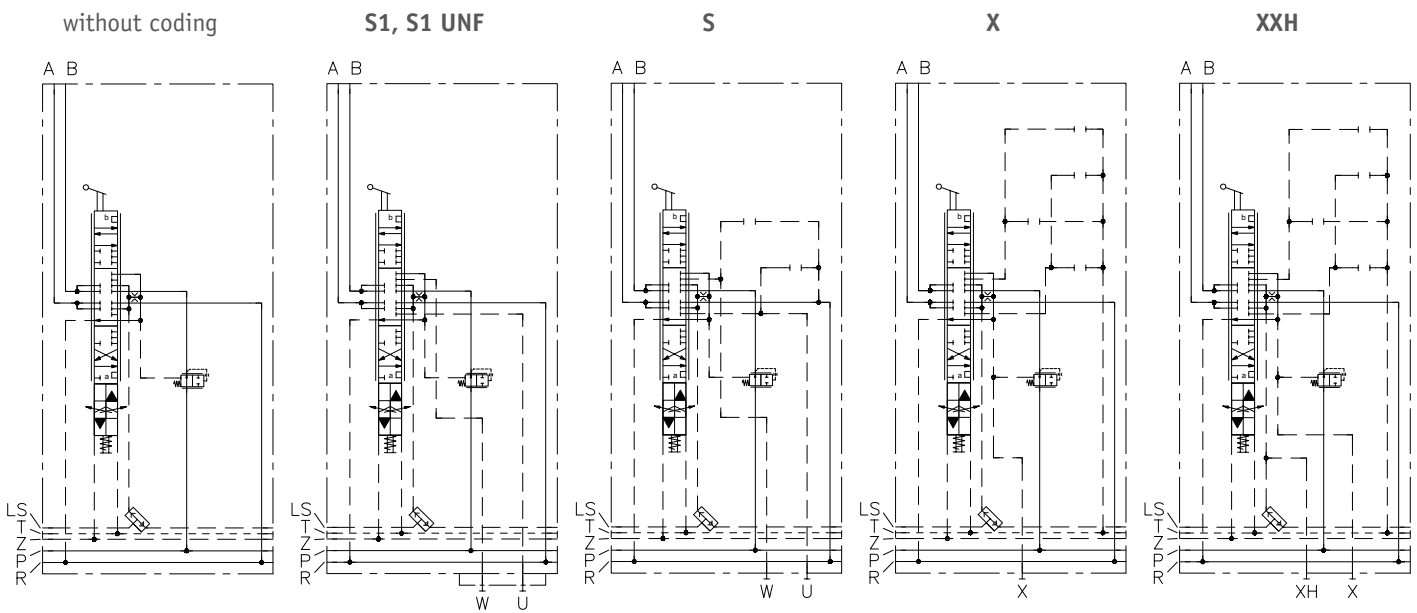

NOTICE

An LS port for external limitation is only possible in conjunction with a 2-way controller (Chapter 2.2.1.2).

NOTICE

Even with LS relief, pressure in consumer channel A or B cannot be reduced completely to 0 bar. The residual pressure in A or B ($p_{min, A/B}$) results from

- a) control pressure in the 2-way controller ($\Delta p_{2\text{-way controller}}$),
- b) internal dynamic pressure in block (Δp_{Block}) and
- c) return pressure (p_{reflux}).

$$p_{min, A/B} = \Delta p_{2\text{-way controller}} + \Delta p_{Block} + p_{reflux}$$

$\Delta p_{2\text{-way controller}}$: see Chapter 2.2.1.2

Δp_{Block} for coding S, S 1 = 5 bar

Δp_{Block} for coding X = 1 bar

2.2.1.10 LS orifice

Coding	Description
without coding	Standard version with \varnothing 0.8 mm orifice
9	Special version with \varnothing 0.9 mm orifice

2.2.1.11 Shuttle valve

Coding	Description	Circuit symbol
without coding	Standard version	
W3	Special version without ball Only useful in manifold's final valve section in case the downstream LS-line is not relieved by the end plate.	

2.2.1.12 Additional functions

Coding	Description	Circuit symbol									
D	<p>Valve section with differential circuit (regeneration function)</p> <p>When in switching position a, the valve section links the A, B and P-lines. In this case, A connects to the piston side and B to the cylinder's rod side.</p> <p>The differential circuit (regeneration function) makes it possible to reach considerably greater cylinder extension speeds at the same pump flow rate. At the same time, however, the force available becomes lower because the pressure applied on the cylinder's piston and rod side is identical. This makes the differential function suitable only for dragging loads.</p> <p>Formula for calculating the required pump flow rate (Q_{pump}) as a function of desired flow rate for cylinder extension (Q_{piston}) and cylinder ratio:</p> $Q_{Pumpe} = Q_{Kolben} \cdot \left(1 - \frac{1}{\phi}\right)$ <p>Only in conjunction with:</p> <table border="1" style="width: 100%; border-collapse: collapse;"> <tr> <td style="width: 33%;">Consumer ports (Chapter 2.2.1.1)</td> <td style="width: 33%;">LS pressure limitation (Chapter 2.2.1.7)</td> <td style="width: 33%;">Actuation (Chapter 2.2.1.13)</td> </tr> <tr> <td>SL 5-5..</td> <td></td> <td>with E</td> </tr> <tr> <td></td> <td>C..</td> <td>with E</td> </tr> </table>	Consumer ports (Chapter 2.2.1.1)	LS pressure limitation (Chapter 2.2.1.7)	Actuation (Chapter 2.2.1.13)	SL 5-5..		with E		C..	with E	
Consumer ports (Chapter 2.2.1.1)	LS pressure limitation (Chapter 2.2.1.7)	Actuation (Chapter 2.2.1.13)									
SL 5-5..		with E									
	C..	with E									

2.2.1.13 Actuation

Actuation types

The different actuation types can be combined with one another.

Coding	Description	Circuit symbol
Electro-hydraulic actuation prepared		
EO	Prepared for electro-hydraulic actuation	--
Manual actuation		
A	<p>Manual actuation with spring return</p> <p>Only in conjunction with actuation variants:</p> <ul style="list-style-type: none"> ▪ A, EOA, AR, EOAR, EAR ▪ EA, EMA(UNF) ▪ HA(UNF), FA(UNF), EHA(UNF), EFA(UNF), EOHA(UNF), EOFA(UNF), EOZA, EOZMA, TA, TOHA, TOFA ▪ PA, EOPA 	
C	<p>Manual actuation, infinitely variable.</p> <p>Only in conjunction with actuation variants:</p> <ul style="list-style-type: none"> ▪ C, EOC 	
R	<p>Manual actuation with 3 positions of neutral position, a or b. With spring return.</p> <p>Without stroke limitation. No flow rate setting possible.</p> <p>Only in conjunction with actuation variants:</p> <ul style="list-style-type: none"> ▪ AR, EOAR ▪ EAR, ER 	
K K12	<p>Joystick actuation</p> <p>Combined manual actuation for two adjacent sections with shared 2-axis actuation.</p> <ul style="list-style-type: none"> ▪ K: with hand lever ▪ K12: With M12 thread for hand lever, supplied without hand lever. Lower actuation torque. $p_{max} = 250 \text{ bar}$ <p>Switching angle: approx. $5^\circ - 19^\circ$</p> <p>Only in conjunction with actuation variants:</p> <ul style="list-style-type: none"> ▪ K ▪ K12 	<p>K, K12</p>

Coding	Description	Circuit symbol
Electro-hydraulic actuation		
EI EM EM UNF	<p>Electro-hydraulic actuation.</p> <ul style="list-style-type: none"> ▪ EI: without stroke limitation ▪ EM: with measurement fitting, with stroke limitation ▪ EM: G 1/4 (ISO 228-1) ▪ EM UNF: SAE-4 or 7/16-20UNF-2B (SAE J 514) <p>Only in conjunction with actuation variants:</p> <ul style="list-style-type: none"> ▪ EI, EM, EIM ▪ EA, EMA ▪ EACAN(L), EMACAN(L), EICAN(L), EIMCAN(L), EHACAN(L), EFACAN(L) ▪ EH, EF, EHA, EFA, EHI, EFI ▪ ER, EAR <p>(also as UNF variants)</p>	

Coding	Description	Circuit symbol
CAN actuation		
CAN CANL	<p>Directly mounted CAN controls</p> <ul style="list-style-type: none"> ▪ CAN: CAN actuation with integrated displacement transducer for spool valve position control. The spool valve characteristic line is linearised and hysteresis is minimised. ▪ CANL: CAN Lite actuation without integrated displacement transducer. Spool valve position is controlled; start and end point are calibrated. <p>Only in conjunction with actuation variants:</p> <ul style="list-style-type: none"> ▪ EACAN(L) ▪ EMACAN(L) ▪ EICAN(L) ▪ EIMCAN(L) ▪ EHACAN(L) ▪ EFACAN(L) <p>(also as UNF variants)</p> <div style="border: 1px solid black; padding: 5px; margin-top: 10px;"> <p>! NOTICE</p> <p>When using CAN actuation, the nominal flow rate may be undershot under certain circumstances. To enable optimum control, an additional tolerance for the mechanical travel stop has been programmed.</p> </div>	

Coding	Description	Circuit symbol
Hydraulic actuation		
H F H UNF F UNF	<p>Hydraulic actuation with pilot pressure ports on spring housing.</p> <p>Ports 1 and 2 parallel to spool valve axis.</p> <ul style="list-style-type: none"> H: Ports 1 and 2 perpendicular to spool valve axis. Not in conjunction with ancillary blocks or intermediate plates that have additional valves, as port 1 would otherwise be hidden by the additional valves. F, FI: Ports 1 and 2 parallel to spool valve axis. H / F: with stroke limitation HI / FI: without stroke limitation H / F: G 1/4 ISO 228-1 H UNF / F UNF: SAE-4 or 7/16-20UNF-2B (SAE J 514) <p>Pilot pressure: min.: approx. 5 max.: approx. 18 bar max. perm.: 50 bar</p> <p>Only in conjunction with actuation variants:</p> <ul style="list-style-type: none"> H, F, EOH, EOF HI, FI, EOH, EOFI HA, FA, EOH, EOHFA EH, EF EHI, EFI EHA, EFA <p>(also as UNF variants)</p>	<p>EHA</p>
EOZ EOZ UNF	<p>Hydraulic actuation with pilot pressure ports in the spool block beneath spring housing.</p> <ul style="list-style-type: none"> EOZ: G 1/8 (ISO 228-1) EOZ UNF: SAE-2 or 5/16-24 UNF-2B (SAE J 514) <p>Only in conjunction with actuation variants:</p> <ul style="list-style-type: none"> EOZM EOZI, EOZIM EOZA, EOZAM <p>(also as UNF variants)</p>	<p>EOZM EOZAM</p>

Coding	Description	Circuit symbol
Pneumatic actuation		
P	<p>Pneumatic actuation with pilot pressure ports on lever housing.</p> <p>Ports 1 and 2: G 1/8 (ISO 228-1)</p> <p>Pilot pressure: approx. 2.5 - approx. 7 bar</p> <p>Only in conjunction with actuation variants:</p> <ul style="list-style-type: none"> P, EOP PA, EOPA 	<p>P</p>

Note concerning actuation variants combining electric and hydraulic actuation (EH, EF, EHI, EFI, EHA, EFA):

Combination with hydraulic joysticks

with closed centre position

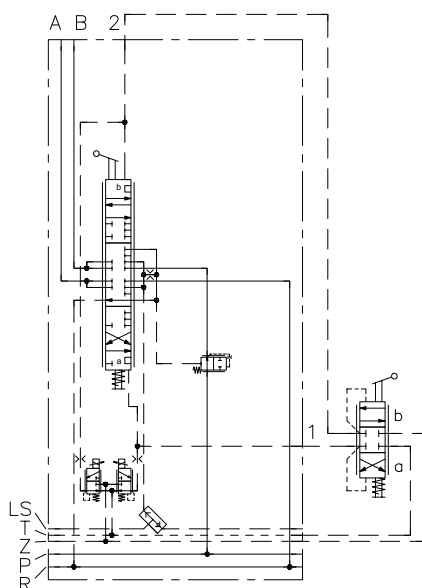

with open centre position

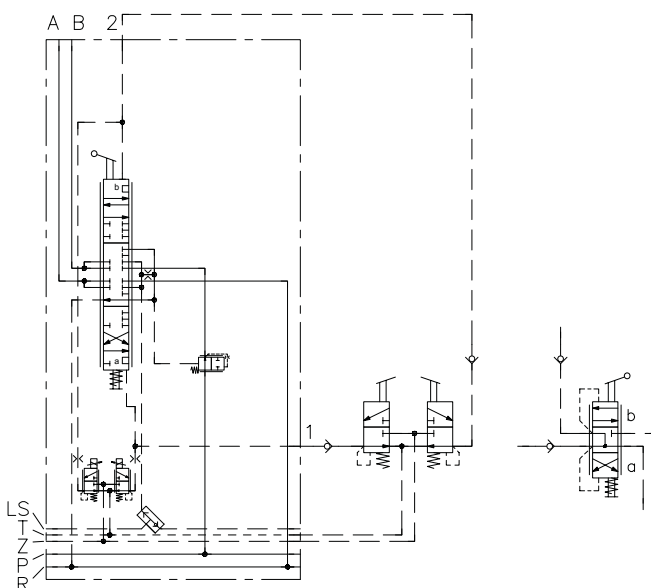

There are two $\varnothing 0.7$ mm orifices between the electro-hydraulic actuation's pilot valves and the pilot pressure ports 1 and 2. The control oil flow for the hydraulic joystick needs to be sufficiently large to compensate for bypass leakage through the orifice.

For joysticks with open centre position, pilot pressure ports 1 and 2 are connected to the tank when the joystick is in neutral position. Electro-hydraulic activation would then result in the entire control oil flow escaping that way, and no pressure would be built up to shift the valve spool. For this reason, additional check valves need to be added to the control lines in this case.

2.2.1.14 Additional elements for actuation

Coding	Description
without coding	Standard version Hand lever straight approx. 177 mm
1	Add-on for manual actuation A
2	<ul style="list-style-type: none"> ▪ 1: Without hand lever ▪ 2: Hand lever straight approx. 106 mm
045	<ul style="list-style-type: none"> ▪ 045: Hand lever 45° curved approx. 152 mm
212	<ul style="list-style-type: none"> ▪ 212: Hand lever 12.5° curved approx. 104 mm <p>Ordering example: SL 5-52 L 120/120 /EA212-DT24</p>
8	Additional description for stronger or weaker spring package
9	<ul style="list-style-type: none"> ▪ 8: Actuation torques as for E actuation (neutral position: 3.0 Nm; end position: 12.0 Nm) ▪ 9: Actuation torques as for H actuation (neutral position: 5.0 Nm; end position: 16.5 Nm) <p>Ordering example: SL 5-52 L 120/120 /EA9-DT24</p>
BE...	<p>Add-on for actuation E0Z actuation. With restrictor check valve type BE 0-... as per D 7555 B in the ports.</p> <p>Ordering example: SL 5-52 L 120/120/E0Z BE0606</p>
04 05 06 07 08	<p>Add-on for actuation with E Additional damping in the electro-hydraulic pilot control.</p> <ul style="list-style-type: none"> ▪ Coding 04 – 0.4 mm orifice ▪ Coding 05 – 0.5 mm orifice ▪ Coding 06 – 0.6 mm orifice ▪ Coding 07 – 0.7 mm orifice ▪ Coding 08 – 0.8 mm orifice <p>Ordering example:</p> <p>SL 5-52 L 120/120/EA 07 (if A and B are the same, 0.7 mm orifice here)</p> <p>SL 5-52 L 120/120/EA 0705 (if A and B are different, 0.7 mm orifice here in A and 0.5 mm orifice in B)</p>

2.2.1.15 Switching position monitoring, displacement transducer

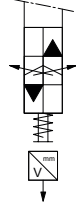
Coding	Description	Circuit symbol
U	<p>Comparator for monitoring spool valve position.</p> <ul style="list-style-type: none"> ▪ In neutral position: A and B on ▪ P → A: A on, B off ▪ P → B: A off, B on ▪ Voltage U: 10 - 32 V DC <p>Connector types: X</p> <p>Ordering example: SL 5-52 L 120/120/EAU</p>	
WA WA-EX WA-IS WA-MSHC	<p>Integrated displacement transducer (Hall sensor) for spool valve position monitoring with analogue output signal.</p> <p>Connector types: X, G, DT, C</p> <ul style="list-style-type: none"> ▪ WA-EX explosion-proof version ▪ WA-IS intrinsically safe version ▪ WA-MSHC explosion-proof version <p>Ordering example: SL 5-52 L 120/120/EAWA-AMP</p>	

2.2.2 Ancillary block

Depending on their version, the ancillary blocks comprise different kinds of additional valves (e.g. shock valves, releasable check valves, load-holding valves or electrically actuated 2/2-way directional seated valves). They can be flange-mounted either on a valve section with flange surface (coding A as per [Chapter 2.2.1.1, "Consumer ports"](#)) or on an intermediate plate ([Chapter 2.2.3](#)).

Ports A and B as per ISO 228-1 or SAE J 514 or JIS B 2351

- /4: G 3/4
- /5: G 1
- /UNF 4: 1 1/16-12 UN-2B (SAE-12)
- /UNF 5: 1 5/16-12 UN-2B (SAE-16)
- /JIS 5: JIS G 1/2

Coding	Description	Circuit symbol			
/5 /UNF 5	No additional function. Measurement fittings a and b. <ul style="list-style-type: none"> ▪ /5: G 1/4 ▪ /UNF 5: 7/16-20UNF-2B 				
/JIS 5	No additional function.				
/5 AS.. BS.. /UNF 5 AS.. BS..	Shock valves in A and B. (Adjustment range: 40 to 420 bar) The shock valves are each connected to their opposite side.				
/5 VV /5 SS /5 VX /5 SX /5 XV /5 XS	Electrically actuated 2/2-way directional seated valve in A, B or A and B. $Q_{max} = 160 \text{ lpm}$; $p_{max} = 350 \text{ bar}$ <ul style="list-style-type: none"> ▪ X: no valve, unrestricted flow ▪ V: closed in neutral position (EM 42 V as per D 7490/1) ▪ V1: closed in neutral position (EM 41 V as per D 7490/1) ▪ S: open in neutral position (EM 42 S as per D 7490/1) ▪ S1: open in neutral position (EM 41 S as per D 7490/1) Ordering example: <table border="1" style="margin-left: 20px;"> <tr> <td>/5</td> <td>X</td> <td>V</td> </tr> </table> <div style="margin-left: 40px;"> 2/2-way directional valve in B 2/2-way directional valve in A </div> Connection thread G 1 Common applications: Seat-tight sealing of consumers.	/5	X	V	<div style="display: flex; justify-content: space-around;"> <div style="text-align: center;"> <p>/5 VX</p> </div> <div style="text-align: center;"> <p>/5 V1X</p> </div> </div> <div style="display: flex; justify-content: space-around;"> <div style="text-align: center;"> <p>/5 XS</p> </div> <div style="text-align: center;"> <p>/5 XS1</p> </div> </div>
/5	X	V			

Coding	Description	Circuit symbol
/5 AN.. BN.. /UNF 5 AN.. BN..	<p>Shock and anti-cavitation valves in A and B. (Adjustment range: 40 to 420 bar)</p> <p>The shock and anti-cavitation valves are each connected to the reflux. Common applications: Protecting cylinders against overpressure.</p> <ul style="list-style-type: none"> ▪ Shock valve similar to MV 6 as per D 7000/1 ▪ Check valve RC 3 as per D 6969 R 	
/4 ASN.. BSN..	<p>Shock valve and anti-cavitation valve in A and B. (Adjustment range: 40 to 420 bar)</p> <p>The shock valves are each connected to their opposite side. The anti-cavitation valves are each connected to the reflux.</p> <ul style="list-style-type: none"> ▪ Shock valve similar to MV 6 as per D 7000/1 ▪ Check valve RK 3 as per D 7445 	
/5 AN.. /5 BN..	<p>Shock valve and anti-cavitation valve.</p> <ul style="list-style-type: none"> ▪ /5 AN: Shock valve in A, anti-cavitation valve in B ▪ /5 BN: Shock valve in B, anti-cavitation valve in A 	<p style="text-align: center;">/5 AN..</p> <p style="text-align: center;">/5 BN..</p>

Coding

Description

/5 AL
/5 BL

Load-holding valves

- /5 AL-...: Load-holding valve in A (type LHT 5 as per D 7918)
- /5 BL-...: Load-holding valve in B (type LHT 5 as per D 7918)

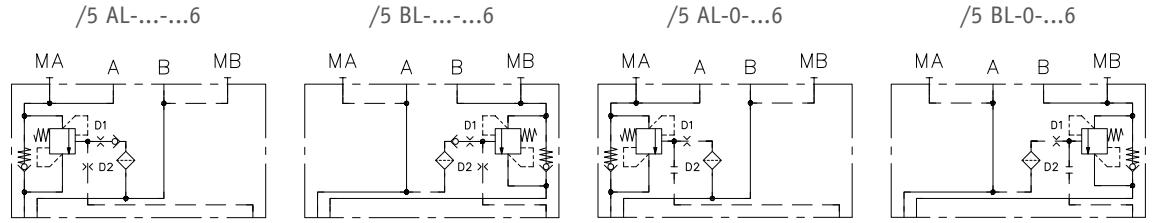

Ordering example:

/5 AL -0 -A 8 /400

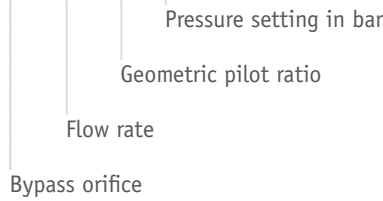

- Inflow orifice D1:
 - Ø 0.5 mm
- Bypass orifice D2:
 - 0 = sealed
 - Ø 0.4 / 0.5 / 0.6 / 0.7 / 0.8 mm
- Geometric pilot ratio:
 - 1:∞ (coding 0)
 - 1:7 (coding 6)

Coding 6

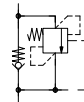

Coding 0

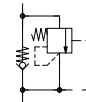

For coding 0, the load pressure has no effect, and the load-holding valve is opened by the pilot pressure alone. In this case, the load-holding valve does not have an overpressure function. The set pressure corresponds to the pilot pressure.

Actual pilot ratio depends on bypass orifice:

Coding	0	4	5	6	7	8
Bypass orifice Ø (mm)	sealed	0,4	0,5	0,6	0,7	0,8
Geometric pilot ratio	1:6	1:6	1:6	1:6	1:6	1:6
Actual pilot ratio	1:6	1:4,26	1:3	1:1,95	1:1,56	1:0,79

Flow rate:

Coding	A	B	C	D	E	F
Q _{max} (lpm)	250	200	150	100	50	25

Coding
Description

/5 AC..
/5 BC..

Load-holding valves

As coding /5 AL... and /5 BL... but with additional spring cavity relief. By relieving the spring cavity, the load-holding valve's opening signal is unaffected by return pressure.

- /5 AC-...: Load-holding valve in A (type LHT 5 as per D 7918)
- /5 BC-...: Load-holding valve in B (type LHT 5 as per D 7918)

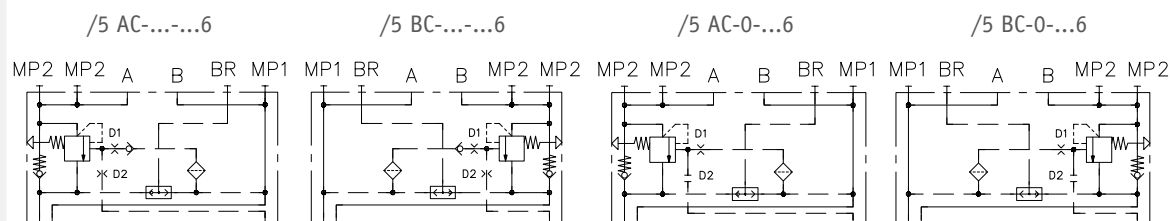

Ordering example:

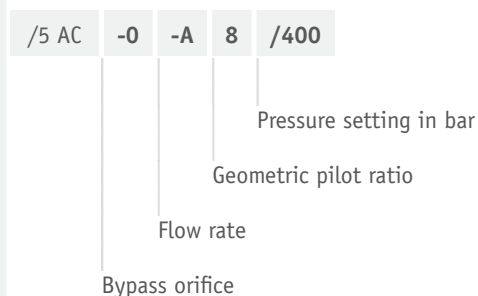

- Inflow orifice D1:
 - Ø 0.5 mm
- Bypass orifice D2:
 - 0 = sealed
 - Ø 0.4 / 0.5 / 0.6 / 0.7 / 0.8 mm
- Geometric pilot ratio:
 - 1:∞ (coding 0)
 - 1:7 (coding 6)

Coding 6

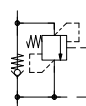

Coding 0

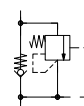

For coding 0, the load pressure has no effect, and the load-holding valve is opened by the pilot pressure alone. In this case, the load-holding valve does not have an overpressure function. The set pressure corresponds to the pilot pressure.

Actual pilot ratio depends on bypass orifice:

Coding	0	4	5	6	7	8
Bypass orifice Ø (mm)	sealed	0,4	0,5	0,6	0,7	0,8
Geometric pilot ratio	1:6	1:6	1:6	1:6	1:6	1:6
Actual pilot ratio	1:6	1:4,26	1:3	1:1,95	1:1,56	1:0,79

Flow rate:

Coding	A	B	C	D	E	F
Q _{max} (lpm)	250	200	150	100	50	25

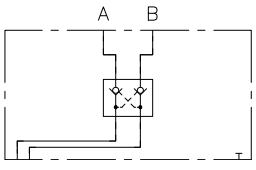
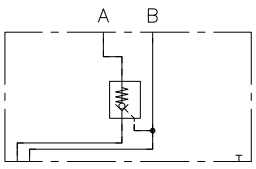
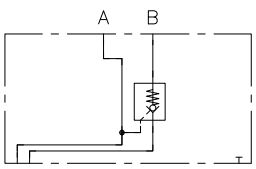
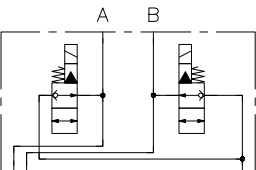
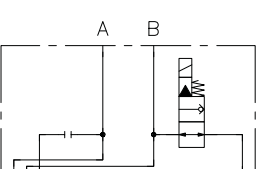
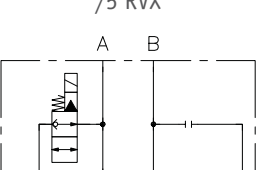
Coding	Description	Circuit symbol				
<p>/5 DRH /5 DRH A /5 DRH B /5 DRH VV /UNF 5 DRH /UNF 5 DRH A /UNF 5 DRH B /UNF 5 DRH VV</p>	<p>Releasable check valves</p> <ul style="list-style-type: none"> ▪ /5 DRH: in A and B ▪ /5 DRH A: in A ▪ /5 DRH B: in B ▪ /5 DRH VV: in A and B, both sides with hydraulic release <p>Check valves used: Type DRH 5 as per D 6110</p> <p>Pressure required for releasing:</p> <ul style="list-style-type: none"> ▪ /5 DRH...: 0.4-fold of shut-off pressure + 3 bar ▪ /5 DRH VV: 0.1-fold of shut-off pressure + 12 bar 	<p>5(UNF 5) DRH (VV)</p>  <p>5(UNF 5) DRH A</p>  <p>5(UNF 5) DRH B</p> 				
<p>/5 RVV /5 RSS /5 RVX /5 RSX /5 RXV /5 RXS /UNF 5 RVV /UNF 5 RSS /UNF 5 RVX /UNF 5 RSX /UNF 5 RXV /UNF 5 RXS</p>	<p>With bypass valves for relieving the consumers. Q_{max} towards R = 40 lpm; p_{max} = 400 bar</p> <ul style="list-style-type: none"> ▪ X: no valve, A/B → R sealed ▪ V: closed in neutral position (EM 22 V as per D 7490/1) ▪ S: open in neutral position (EM 22 S as per D 7490/1) <p>Ordering example:</p> <table border="1" data-bbox="327 1187 502 1232"> <tr> <td>/5</td> <td>R</td> <td>X</td> <td>V</td> </tr> </table> <p>2/2-way directional valve in B 2/2-way directional valve in A Release towards R Connection thread G 1</p>	/5	R	X	V	<p>/5 RVV</p>  <p>/5 RXS</p>  <p>/5 RVX</p> 
/5	R	X	V			

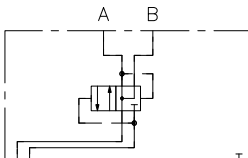
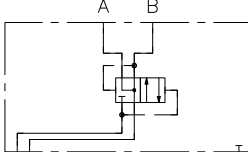
Coding	Description	Circuit symbol
/54 DFA /54 DFB	<p>Differential function.</p> <p>The differential circuit (regeneration function) makes it possible to reach considerably greater cylinder extension speeds at the same pump flow rate. At the same time, however, the force available becomes lower because the pressure applied on the cylinder's piston and rod side is identical; only the effective areas differ. This makes the differential function suitable for loads that drag on the cylinder.</p> <ul style="list-style-type: none"> ▪ /54 DFA: cylinder's piston side on A-side, rod side on B-side ▪ /54 DFB: cylinder's piston side on B-side, rod side on A-side <p>Formula for calculating the required pump flow rate (Q_{pump}) as a function of desired flow rate for cylinder extension (Q_{piston}) and cylinder ratio (ϕ):</p> $Q_{\text{Pumpe}} = Q_{\text{Kolben}} \cdot \left(1 - \frac{1}{\phi}\right)$ <p>! NOTICE In the neutral position, the load should not be a dragging load, to ensure there is no negative pressure on the piston side. Otherwise there may be undefined changes to the piston's switching position in the ancillary block.</p>	<p>/54 DFA</p>  <p>/54 DFB</p> 

! NOTICE
For combinations comprising two intermediate plates (Chapter 2.2.3) and an ancillary block (Chapter 2.2.2), certain configurations might be unavailable because the maximum permissible screw length is exceeded.

2.2.3 Intermediate plate (on the consumer side)

Coding	Description	Circuit symbol
/Z 30	Spacer plate, height 30 mm, for compensating height differences relative to adjacent valve sections.	
/Z 70	Spacer plate, height 70 mm, for compensating height differences relative to adjacent valve sections.	

Coding

Description

/Z ALW-...
/Z BLW-...

Load-holding valves.
With external pressure tapping for the consumer that currently has the higher load.

- /5 AL...: Load-holding valve in A (type LHT 5 as per D 7918)
- /5 BL...: Load-holding valve in B (type LHT 5 as per D 7918)

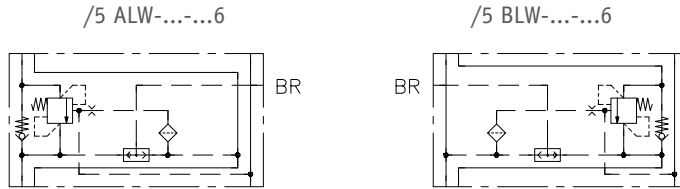

Ordering example:

/Z ALW -0 -A 8 /400

Pressure setting in bar
Geometric pilot ratio
Flow rate
Bypass orifice

- Inflow orifice D1:
- Ø 0.5 mm
- Bypass orifice D2:
- 0 = sealed
- Ø 0.4 / 0.5 / 0.6 / 0.7 / 0.8 mm
- Geometric pilot ratio:
- 1:6 (coding 7)
- 1:∞ (coding 0)

Coding 6

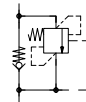

Coding 0

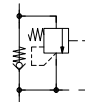

For coding 0, the load pressure has no effect, and the load-holding valve is opened by the pilot pressure alone. In this case, the load-holding valve does not have an overpressure function. The set pressure corresponds to the pilot pressure.

Actual pilot ratio depends on bypass orifice:

Coding	0	4	5	6	7	8
Bypass orifice Ø (mm)	sealed	0,4	0,5	0,6	0,7	08
Geometric pilot ratio	1:6	1:6	1:6	1:6	1:6	1:6
Actual pilot ratio	1:6	1:4,26	1:3,0	1:1,95	1:1,56	1:0,79



Flow rate:

Coding	A	B	C	D	E	F
Q _{max} (lpm)	250	200	150	100	50	25

Coding	Description	Circuit symbol			
/ZVV /ZSS	Electrically actuated 2/2-way directional seated valve in A, B or A and B. $Q_{\max} = 160 \text{ lpm}$; $p_{\max} = 350 \text{ bar}$ <ul style="list-style-type: none"> ▪ X: no valve, unrestricted flow ▪ V: closed in neutral position (EM 42 V as per D 7490/1) ▪ S: open in neutral position (EM 42 S as per D 7490/1) 				
/ZVX /ZXV	Ordering example: <table border="1" style="margin-left: 20px;"> <tr> <td style="padding: 2px 5px;">/Z</td> <td style="padding: 2px 5px;">X</td> <td style="padding: 2px 5px;">V</td> </tr> </table> <p style="margin-left: 40px;">2/2-way directional valve in B</p>	/Z	X	V	
/Z	X	V			
/ZSX /ZXS	<p style="margin-left: 20px;">2/2-way directional valve in A</p> <p>Connection thread G 1</p> <p>Common applications: seat-tight sealing of consumers.</p>				

! **NOTICE**
 For combinations comprising two intermediate plates and an ancillary block ([Chapter 2.2.2](#)), certain configurations might be unavailable because the maximum permissible screw length is exceeded.

2.3 Series intermediate plate

Coding	Description
<p>ZPL 55/9 ZPL 55/15</p>	<p>Spacer plate.</p> <ul style="list-style-type: none"> ▪ ZPL 55/9: 9 mm ▪ ZPL 55/15: 15 mm <p>ZPL 55(/9, /15)</p>  <div style="border: 1px solid gray; padding: 5px; margin-top: 10px;"> <p>! NOTICE ZPL 55/9 is installed after a connection block as standard if a valve section with coding A as per Chapter 2.2.1.1, "Consumer ports" follows.</p> </div>
<p>ZPL 55/9/XR</p>	<p>Locks the R-line.</p> <p>ZPL 55/9/XR</p> 

Coding

Description

ZPL 5 P6 R6
ZPL 5 P6 RX6
ZPL 5 P6 R6 /R1

- Ports P, R and T
- ZPL 5 P6 R6:
 - Ports in P, R and T
 - Measurement fitting in P
 - ZPL 5 P6 RX6:
 - Ports in P, R and T
 - Measurement fitting in P
 - R only connected to valve sections that are installed after the intermediate plate
 - ZPL 5 P6 R6 /R1:
 - Ports in P, R and T
 - Check valve in R

P, R: G 1 1/4
T, M: G 1/4
Width: 62.5 mm

ZPL 5 P6 R6

ZPL 5 P6 RX6

ZPL 5 P6 R6 /R1

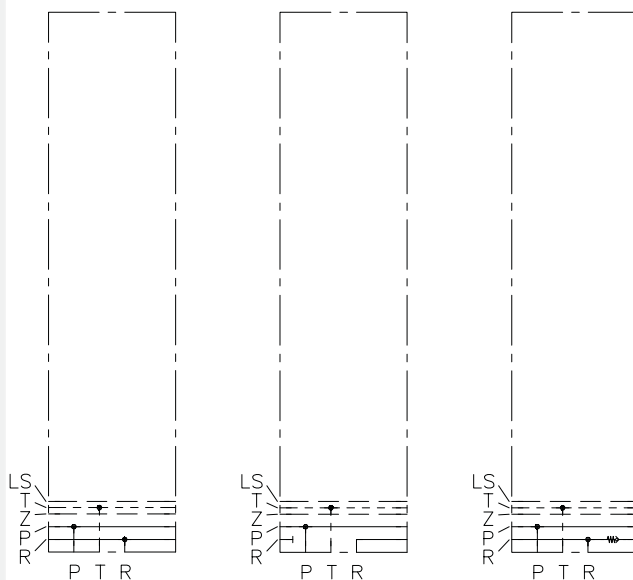

Coding

Description

ZPL 50 ...
ZPL 50 T ...

Locks the P-line, the LS line and optionally the pilot pressure Z.

Due to this intermediate plate, the valve sections in a valve bank can operate in two separate systems.

- P-line locked
- External LS connection – LS2 (optionally with LS damping element)
- Optional Z-line lock

Ordering example:

ZPL 50 **T** **S**

Damping element as per [Chapter 2.1.6](#)

Z-line:

- - : not locked
- T : locked

ZPL 50

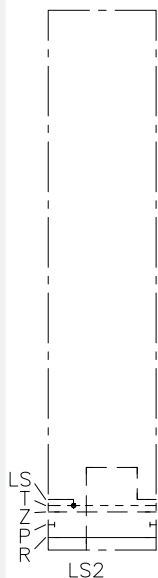

ZPL 50 S



ZPL 50 T

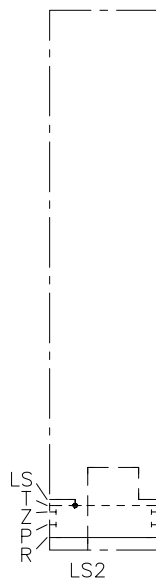

ZPL 50 T S

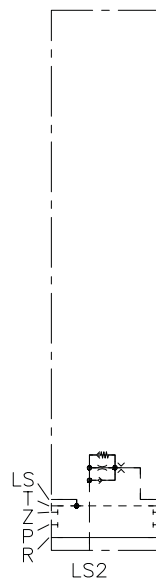

! NOTICE

In conjunction with the end plate E...PSL 56, the LS ports LS 2 (to ZPL 50...) and DW 2 (to E...PSL 56) must be connected externally.

Coding

Description

ZPL 531
ZPL 531 /RB
ZPL 531 /XR
ZPL 531 /RB XR

Transition plate to PSL size 3 as per D 7700-3.

- ZPL 531: Transition to PSL size 3
- ZPL 531 /RB: Transition to PSL size 3. T-line internally connected with R-line.
- ZPL 531 /XR: Transition to PSL size 3. R-line locked.
- ZPL 531 /RB XR: Transition to PSL size 3. T-line internally connected with R-line. R-line locked.

Width: 42.5 mm

ZPL 531

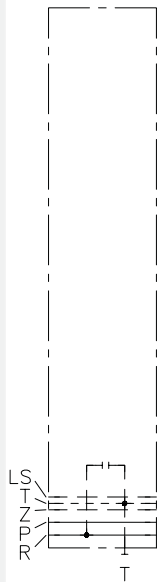

ZPL 531 /RB



ZPL 531 /XR

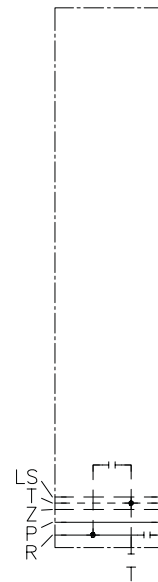

ZPL 531 /RB XR

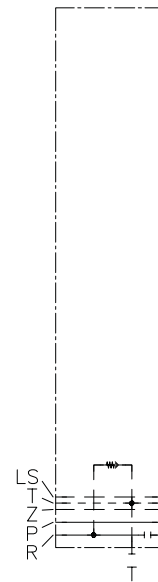

ZPL 521

Transition plate to PSL size 2 as per D 7700-2.
With sealed T port.

T: G 1/4

ZPL 521



2.4 End plate

Coding	Description		
E 1, E 1 UNF E 7 E 13, E 13 UNF	<p>T port for external recirculation of control oil to tank.</p> <ul style="list-style-type: none"> E 7: with additional R port E 13: with additional P port <p>P: G 1 (1 5/16-12 UN-2B) R: G 1 1/4</p>		
E 2 E 8 E 14, E 14 UNF	<p>With additional Y port for connecting a downstream manifold's LS signal. T port for external recirculation of control oil to tank.</p> <ul style="list-style-type: none"> E 8: with additional R port E 14: with additional P port <p>P: G 1 (1 5/16-12 UN-2B) R: G 1 1/4</p>		
E 4, E 4 UNF E 9 E 15, E 15 UNF	<p>T-line internally linked with R-line for internal recirculation of control oil through R line.</p> <ul style="list-style-type: none"> E 9: with additional R port E 15: with additional P port <p>P: G 1 (1 5/16-12 UN-2B) R: G 1 1/4</p>		
E 5 E 10 E 16, E 16 UNF	<p>With additional Y port for connecting a downstream manifold's LS signal. T-line internally linked with R-line for internal recirculation of control oil through R line.</p> <ul style="list-style-type: none"> E 10: with additional R port E 16: with additional P port <p>P: G 1 (1 5/16-12 UN-2B) R: G 1 1/4</p>		
E 3 E 6	<p>With integrated 3/2-way directional valve (WN 1 H as per D 7470 A/1) to switch P to LS when required and shut off the PSL connection block's unpressurised circulation.</p> <ul style="list-style-type: none"> E 3: T port for external recirculation of control oil to tank E 6: T-line internally linked with R-line for internal recirculation of control oil through R line 		
E 7 A...	<p>With additional internal control oil supply in Z as per Chapter 2.1.7 T port for external recirculation of control oil to tank. Additional R port. R: G 1 1/4</p> <p>Ordering example:</p> <table border="1" data-bbox="319 1500 446 1556"> <tr> <td>E 7 A</td> <td>1</td> </tr> </table> <p>Pilot pressure:</p> <ul style="list-style-type: none"> 1: 20 bar 2: 40 bar 	E 7 A	1
E 7 A	1		

Coding

Description

E 8 A...

With additional internal control oil supply in Z as per [D 7470 A/1](#).
Y port for connecting a downstream manifold's LS signal.
T port for external recirculation of control oil to tank.

- E 8: with additional R port

R: G 1 1/4

Ordering example:

E 8 A 1

Pilot pressure:

- 1: 20 bar
- 2: 40 bar

E 1 PSL 56.../...

T port for external recirculation of control oil to tank.

Additionally, the end plate has the functionality of a PSL connection block as per [Chapter 2.1](#). In conjunction with ZPL 50 ... as per [Chapter 2.3](#), can be used as a separate second circuit.

The following are separately provided or selectable for this purpose:

- P and R port
- Pilot-controlled pressure-limiting valve
- 3-way controller and additional elements as per [Chapter 2.1.5](#)
- Pilot pressure selectable as per [Chapter 2.1.7](#)
- LS relief or LS pressure limitation as per [Chapter 2.1.8](#)

An LS damping element as per [Chapter 2.1.6](#) can be selected in ZPL 50... as per [Chapter 2.3](#).

Ordering example:

E 1 PSL 56 H 2 F /350

Pressure limitation in bar

LS relief or LS pressure limitation as per [Chapter 2.1.8](#)

Internal control oil supply as per [Chapter 2.1.7](#)

for 3-way controller as per [Chapter 2.1.5](#)

End plate

P2: G 1

R2: G 1 1/4



NOTICE

In conjunction with the intermediate plate ZPL 50..., the LS ports LS 2 (to ZPL 50...) and DW 2 (to E...PSL 56) must be connected externally.

Coding
Description
E 4 PSL 56.../...

T-line internally linked with R-line for internal recirculation of control oil through R line.

Additionally, the end plate has the functionality of a PSL connection block as per [Chapter 2.1](#). In conjunction with ZPL 50 ... as per [Chapter 2.3](#), can be used as a separate second circuit.

The following are separately provided or selectable for this purpose:

- P and R port
- Pilot-controlled pressure-limiting valve
- 3-way controller and additional elements as per [Chapter 2.1.5](#)
- Pilot pressure selectable as per [Chapter 2.1.7](#)
- LS relief or LS pressure limitation as per [Chapter 2.1.8](#)

An LS damping element as per [Chapter 2.1.6](#) can be selected in ZPL 50... as per [Chapter 2.3](#).

Ordering example:

E 4 PSL 56	H	2	F	/350
------------	---	---	---	------

Pressure limitation in bar

LS relief or LS pressure limitation as per [Chapter 2.1.8](#)

Internal control oil supply as per [Chapter 2.1.7](#)

Additional elements for 3-way controller as per [Chapter 2.1.5](#)

End plate

P2: G 1

R2: G 1 1/4

! **NOTICE**

In conjunction with the intermediate plate ZPL 50..., the LS ports LS 2 (to ZPL 50...) and DW 2 (to E...PSL 56) must be connected externally.

Coding

Description

E 1 PSV 56.../...

T port for external recirculation of control oil to tank.

Additionally, the end plate has the functionality of a PSL connection block as per [Chapter 2.1](#). In conjunction with ZPL 50... as per [Chapter 2.3](#), can be used as a separate second circuit.

The following are separately provided or selectable for this purpose:

- P and R port
- Pilot-controlled pressure-limiting valve
- Pilot pressure selectable as per [Chapter 2.1.7](#)
- LS relief or LS pressure limitation as per [Chapter 2.1.8](#)

An LS damping element as per [Chapter 2.1.6](#) can be selected in ZPL 50... as per [Chapter 2.3](#).

Ordering example:

E 1 PSV 56	2	F	/350
------------	---	---	------

Pressure limitation in bar

LS relief or LS pressure limitation as per [Chapter 2.1.8](#)

Internal control oil supply as per [Chapter 2.1.7](#)

End plate

P2: G 1

R2: G 1 1/4



NOTICE

In conjunction with the intermediate plate ZPL 50..., it is necessary to pick up the LS signal on port LS 2 to ZPL 50....

Coding
Description
E 4 PSV 56.../...

T-line internally linked with R-line for internal recirculation of control oil through R line.

 Additionally, the end plate has the functionality of a PSL connection block as per [Chapter 2.1](#). In conjunction with ZPL 50... as per [Chapter 2.3](#), can be used as a separate second circuit.

The following are separately provided or selectable for this purpose:

- P and R port
- Pilot-controlled pressure-limiting valve
- Pilot pressure selectable as per [Chapter 2.1.7](#)
- LS relief or LS pressure limitation as per [Chapter 2.1.8](#)

 An LS damping element as per [Chapter 2.1.6](#) can be selected in ZPL 50... as per [Chapter 2.3](#).

Ordering example:

E 1 PSV 56	2	F	/350
------------	---	---	------

Pressure limitation in bar

 LS relief or LS pressure limitation as per [Chapter 2.1.8](#)

 Internal control oil supply as per [Chapter 2.1.7](#)

End plate

P2: G 1

R2: G 1 1/4

NOTICE

In conjunction with the intermediate plate ZPL 50..., it is necessary to pick up the LS signal on port LS 2 to ZPL 50....

NOTICE

Internal control oil recirculation through R line is permissible only for return pressures < 10 bar.

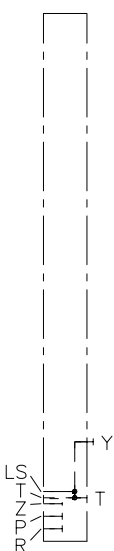
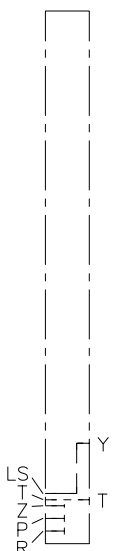
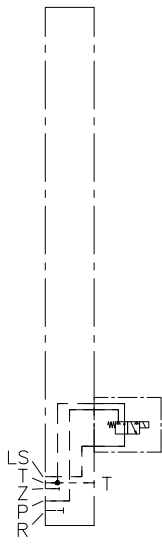
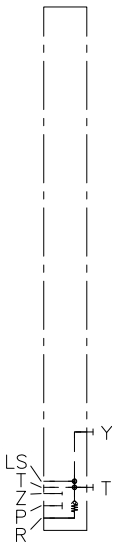
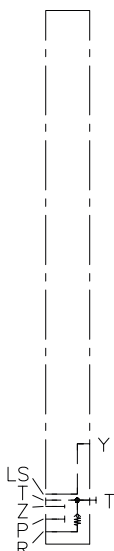
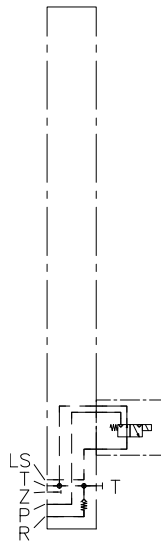
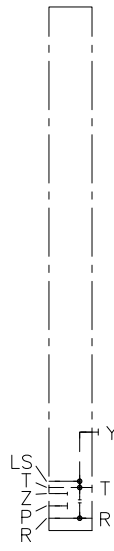
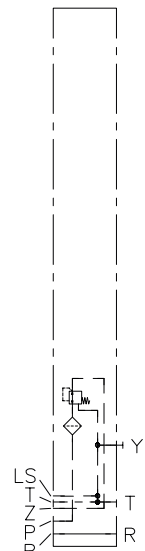
Circuit symbols
E 1 (UNF)

E 2 (UNF)

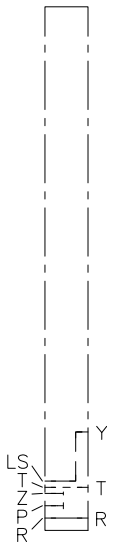
E 3

E 4 (UNF)

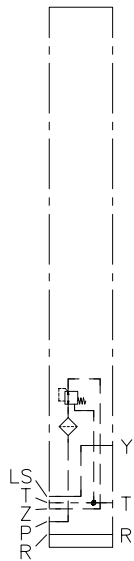
E 5

E 6

E 7

E 7 A1(2)

E 8



E 8 A1(2)



E 9

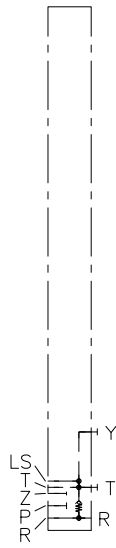

E 10

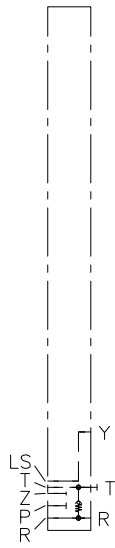

E 13 (UNF)

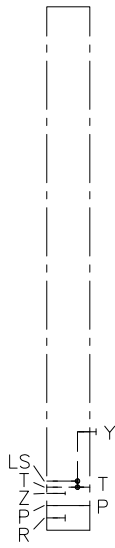

E 14 (UNF)

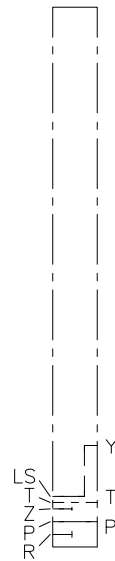

E 15 (UNF)

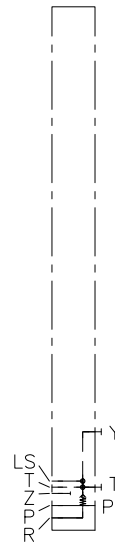

E 16 (UNF)



E 1 PSL 56../..

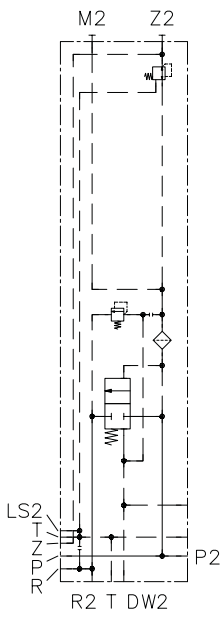

E 4 PSL 56../..

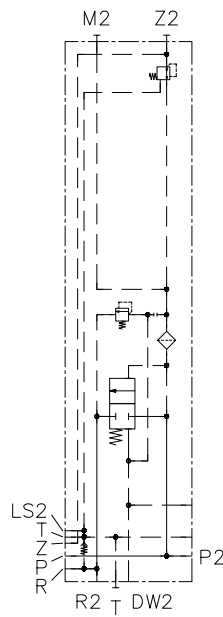

E 1 PSV 56../..

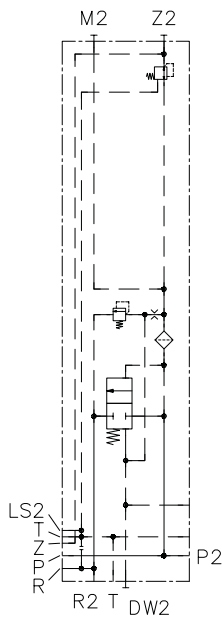

E 4 PSV 56../..

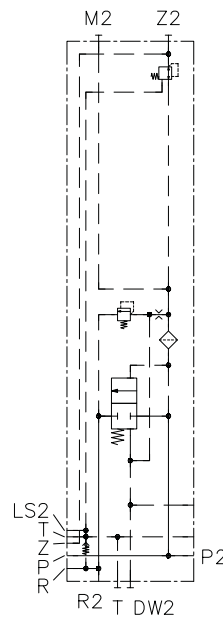

2.5 Solenoid voltage and solenoid version

2.5.1 Standard solenoid versions

Coding	Electrical connection	Nominal voltage	Protection class (IEC 60529)	Valve section with electro-hydraulic actuation (EI, EA, EH, EHA etc.)	Can be combined with certain additional valves				
					WN	BVE	EM, EMP	F, FH	FP, FPH
AMP 12 K 4 AMP 24 K 4	AMP Junior Timer	12 V DC 24 V DC	IP 67	4-pin, connector position front		●	●		●
AMP 12 H 4 AMP 24 H 4		12 V DC 24 V DC		4-pin, connector position side (bottom)		●	●		●
AMP 12 H 4 T AMP 24 H 4 T		12 V DC 24 V DC		4-pin, connector position side (bottom), with override		●	●		●
AMP 12 K AMP 24 K		12 V DC 24 V DC		3-pin, connector position front		●	●		●
DT 12 DT 24	German (DT 04-4P)	12 V DC 24 V DC	IP 69k	4-pin, connector position side (bottom)		●	●		●
DT 12 T DT 24 T		12 V DC 24 V DC		4-pin, connector position side (bottom), with override		●	●		●
DT 12 TH DT 24 TH		12 V DC 24 V DC		4-pin, connector position side (bottom), with override button		●	●		●
DT 12 K DT 24 K		12 V DC 24 V DC		4-pin, connector position front		●	●		●
S 12 S 24	Bayonet coupling PA6 Schlemmer	12 V DC 24 V DC	IP 67	3-pin, connector position front	●	●	●		●
S 12 T S 24 T		12 V DC 24 V DC		3-pin, connector position front, with override	●	●	●		●
G 12 G 24	EN 175 301-803 A <ul style="list-style-type: none"> ▪ G: with male connector (MSD 3-309 as per D 7163) ▪ X: without male connector ▪ L: with male connector with LED (SVS 296365 as per D 7163) ▪ L5K: with male connector with LED and 5 m cable (L5K-VZP as per D 7163 Erg. 78/1) ▪ L10K: with male connector with LED and 10 m cable (L10K-VZP as per D 7163 Erg. 78/1) 	12 V DC 24 V DC	IP 65	3-pin, connector position side (bottom)	●	●	●	●	●
X 12 X 24		12 V DC 24 V DC		●	●	●	●	●	
L 12 L 24		12 V DC 24 V DC		●	●	●	●	●	
L5K 12 L5K 24		12 V DC 24 V DC		●	●	●	●	●	
L10K 12 L10K 24		12 V DC 24 V DC		●	●	●	●	●	
G 12 T G 24 T		12 V DC 24 V DC		3-pin, connector position side (bottom), with override	●	●	●	●	●
X 12 T X 24 T		12 V DC 24 V DC		●	●	●	●	●	
L 12 T L 24 T		12 V DC 24 V DC		●	●	●	●	●	
L5K 12 T L5K 24 T		12 V DC 24 V DC		●	●	●	●	●	
L10K 12 T L10K 24 T		12 V DC 24 V DC		●	●	●	●	●	

Coding	Electrical connection	Nominal voltage	Protection class (IEC 60529)	Valve section with electro-hydraulic actuation (EI, EA, EH, EHA etc.)	Can be combined with certain additional valves							
					WN	BVE	EM, EMP	F, FH	FP, FPH			
G 12 TH G 24 TH	EN 175 301-803 A ■ G: with male connector (MSD 3-309 as per D 7163) ■ X: without male connector ■ L: with male connector with LED (SVS 296365 as per D 7163) ■ L5K: with male connector with LED and 5 m cable (L5K-VZP as per D 7163 Erg. 78/1) ■ L10K: with male connector with LED and 10 m cable (L10K-VZP as per D 7163 Erg. 78/1)	12 V DC 24 V DC	IP 65	3-pin, connector position side (bottom), with override button	●	●	●	●	●			
X 12 TH X 24 TH		12 V DC 24 V DC			●	●	●	●	●			
L 12 TH L 24 TH		12 V DC 24 V DC			●	●	●	●	●			
L5K 12 TH L5K 24 TH		12 V DC 24 V DC			●	●	●	●	●			
L10K 12 TH L10K 24 TH		12 V DC 24 V DC			●	●	●	●	●			
G 12 DS * G 24 DS *		12 V DC 24 V DC			IP 65	3-pin, connector position side (bottom), deep-sea version (coil and connector socket not potted)						
X 12 DS * X 24 DS *							12 V DC 24 V DC					
G 12 H 4 G 24 H 4							12 V DC 24 V DC	4-pin, connector position side (bottom)	●	●	●	●
X 12 H 4 X 24 H 4		12 V DC 24 V DC			●	●	●		●	●		
L 12 H 4 L 24 H 4		12 V DC 24 V DC			●	●	●		●	●		
X 12 C X 24 C		EN 175 301-803 C			12 V DC 24 V DC	IP 65	3-pin, connector position front					
X 12 C 4 X 24 C 4					12 V DC 24 V DC			4-pin, connector position front				
DTL 12 DTL 24		MIL-DTL-38999 series III			12 V DC 24 V DC	IP 67	4-pin, connector position side (bottom)			●		
ITT 12 ITT 24	VG 95234 MIL	12 V DC 24 V DC			●							

* (available upon request only)

Electrical connection for additional valves:

- **WN:** see [D 7470 A/1](#)
- **BVE:** see [D 7921](#)
- **EM 21:** see [D 7490/1 E](#)
- **EM 31, EMP 31:** see [D 7490/1](#)
- **SWS:** see [D 7951](#)
- **PM 1, PMZ 1:** see [D 7625](#)

Different types of plug (e.g. EA actuation with AMP 24 K 4 and WN valve with G 24) are available upon request.

Electrical connection for LS relief coding F 1, F 2, F3, FH 1, FH 2, FH 3:

The electrical LS relief's on/off twin solenoids are only available with DIN connectors and manual override (coding -G...T(H), -X...T(H) or -L...T(H)). Should you require another plug option, the electro-proportional LS pressure limitation coding FP.., FPH.. can be used instead.

Electrical connection for electro-proportional LS pressure limitation coding FP.., FPH..:

Only twin solenoids with manual override (coding -...T or -...TH) are possible.

If a twin solenoid without manual override was chosen for the valve section's electro-hydraulic actuation, the same twin solenoid type is automatically used for the LS pressure limitation's electro-proportional actuation, but with additional manual override. If the twin solenoid type is not possible with manual override, coding -G...T is used by default.

2.5.2 Solenoid versions for potentially explosive atmospheres

Coding	Description
X 24 TEX 4 70 FM	Explosion-proof solenoid in terminal box Information on the solenoid is provided in the operating instructions B ATEX
G 24 EX G 24 EX-10 m	Explosion-proof solenoid with cable <ul style="list-style-type: none"> ▪ No additional specification: with 3 m cable ▪ 10 m: with 10 m cable Information on the solenoid is provided in the operating instructions B ATEX
G 12 IS G 12 IS-10 m	Explosion-proof solenoid with cable. <ul style="list-style-type: none"> ▪ No additional specification: with 3 m cable ▪ 10 m: with 10 m cable
G 12 M2FP G 12 M2FP-10 m	Information on the solenoid is provided in the operating instructions B ATEX
G 24 MSHA G 24 MSHA-10 m	

3 Parameters

3.1 General information

Designation	Proportional directional spool valve PSL, PSV, PSM
Design	Manifold with up to 12 valve sections
Material	Steel, nitrided (anti-corrosion) surfaces, internal function parts tempered and polished, solenoids' surfaces galvanised
Attachment	M10 mounting thread, see Chapter 4, "Dimensions"
Installation position	Any
Ports/connections	<ul style="list-style-type: none"> ▪ P = Pump ▪ R = Reflux ▪ A, B = Consumers ▪ LS, DW, U, W, X, XH, Y = load pressure signals ▪ M = Pressure gauge connection for pump pressure ▪ a, b = Pressure gauge connection for consumer pressure ▪ Z = Pilot pressure ▪ T = Tank line for control oil <p>Connecting thread:</p> <ul style="list-style-type: none"> ▪ P, R, A, B = as per type designation ▪ M, LS, DW, Y, Z, T = G 1/4 (ISO 228-1) or SAE-4, or 7/16-20 UNF-2B (SAE J 514) ▪ U, W, X, XH = G 1/8 (ISO 228-1) ▪ a, b = G 1/4 or G 1/8 (ISO 228-1)
Hydraulic fluid	<p>Hydraulic fluid, according to DIN 51 524 Parts 1 to 3; ISO VG 10 to 68 according to DIN ISO 3448</p> <p>Viscosity range: 4 - 1500 mm²/s</p> <p>Optimal operating range: approx. 10 - 500 mm²/s</p> <p>Also suitable for biologically degradable hydraulic fluids type HEPG (polyalkylene glycol) and HEES (synthetic ester) at operating temperatures up to approx. +70°C.</p> <p>Not suitable for HETG such as rapeseed oil and water-glycol solutions, e.g. HFA and HFC.</p>
Cleanliness level	<p>ISO 4406</p> <hr style="width: 20%; margin-left: 0;"/> <p>20/17/14</p>
Temperatures	<p>Environment: approx. -40 to +80 °C, hydraulic fluid: -25 to +80 °C, pay attention to the viscosity range.</p> <p>Start temperature: down to -40 °C is permissible (take account of the start viscosities!), as long as the steady-state temperature is at least 20 K higher during subsequent operation.</p> <p>Biologically degradable hydraulic fluids: note manufacturer specifications. With consideration for the seal compatibility, not above +70°C.</p> <div style="border: 1px solid black; padding: 5px; margin-top: 10px;"> <p>! NOTICE Note restrictions on explosion-proof solenoid.</p> </div>

3.2 Pressure and volumetric flow

Operating pressure	<ul style="list-style-type: none"> ▪ $p_{max} = 400$ bar (ports P, P1, P2, A, B, LS, M, Y) ▪ Pilot pressure ≤ 40 bar (port Z) ▪ Return pressure ≤ 50 bar (ports R, R1, T) for high return pressures, T port should be routed to the tank separately (end plate E 1, E 2, E 3, etc. see Chapter 2.4, "End plate")
Flow rate	<ul style="list-style-type: none"> ▪ Q_{max} connection block: see Chapter 3.4, "Characteristic lines" ▪ Q_{max} consumer: see Chapter 2.2.1.6, "Flow rate"

3.3 Weight

Connection block	<p>Type</p> <p>PSV 5(6)...-5 = 4.5 kg</p> <p>PSV 5(6).../...-5 = 7.7 kg</p> <p>PSM 6... = 4.5 kg</p> <p>Supplement</p> <p>F, D, ZD, ZDM, ZDP, VD, + 0.6 kg</p>
Directional valve section	<p>Valve section with actuation</p> <p>Coding</p> <p>A, E, H, F, P, E0A = 3.7 kg</p> <p>EA, HA, PA = 4.1 kg</p> <p>EHA = 4.6 kg</p> <p>Supplement</p> <p>C..., S + 0.0 kg</p> <p>A...B...FP(H) 1(2,3), S1 + 0.4 kg</p>
Ancillary block	<p>Coding</p> <p>/UNF 5 = 1.5 kg</p> <p>/UNF 5 AS.. BS.. = 2.4 kg</p> <p>/UNF 5 AN.. BN.. = 2.3 kg</p> <p>/5 AL.., /5 BL.. = 3.4 kg</p> <p>/5 VV(VX, XV) = 2.4 kg</p> <p>/UNF 5 DRH = 2.3 kg</p> <p>/54 DFA, /54 DFB = 2.4 kg</p> <p>/5 RVV, RSS = 2.4 kg</p>

Series intermediate plate	Coding	
	ZPL 5 S/H	= 5.0 kg
	ZPL 5 V/E	= 5.0 kg
	ZPL 5 P6 R6	= 5.9 kg
	ZPL 531	= 3.4 kg
	ZPL 521	= 3.4 kg
	ZPL 55/9	= 0.7 kg
ZPL 50 T...	= 2.6 kg	
End plate	Coding	
	E 1(UNF), E 2(UNF), E 4(UNF), E 5(UNF)	= 2.5 kg
	E 3, E 6	= 3.1 kg
	E 7(UNF) to E 16(UNF)	= 3.0 kg
	E 7 A 1(2), E 8 A 1(2)	= 2.5 kg
	E 1, E 4 PSL(V) 56	= 7.7 kg

3.4 Characteristic lines

Viscosity of the hydraulic fluid approx. 60 mm²/s

3.4.1 Connection block

Pressure-limiting valve (P → R)

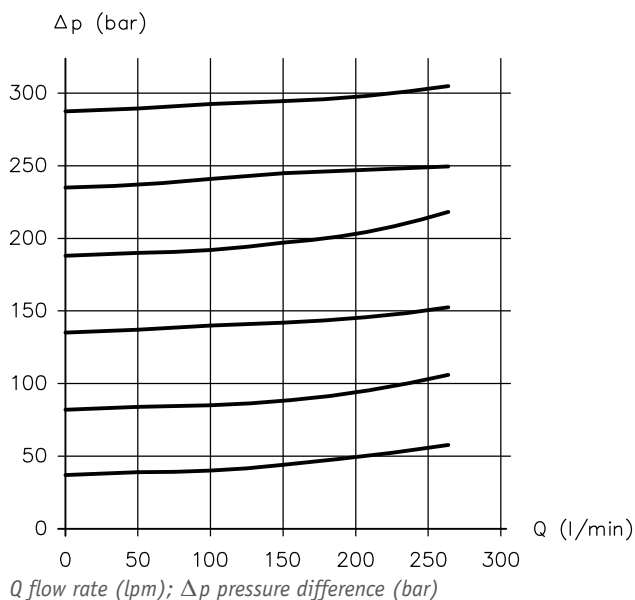

Circulation pressure (P → R) in PSL connection blocks

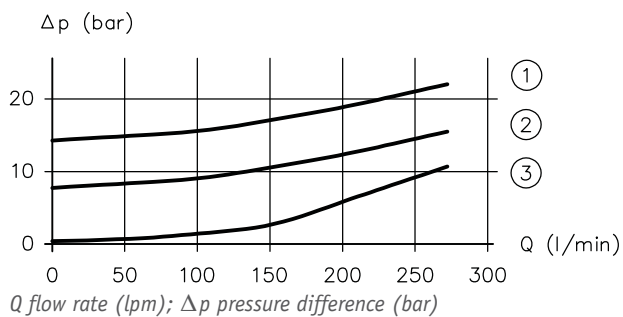

- 1 PSL (UNF) 5(6) H...-5
- 2 PSL (UNF) 5(6) ...-5
- 3 PSL (UNF) 5(6) U(Y)...-5

Electro-proportional LS pressure limitation as per Chapter 2.1.8

Coding **V, Z, ZM, ZP**

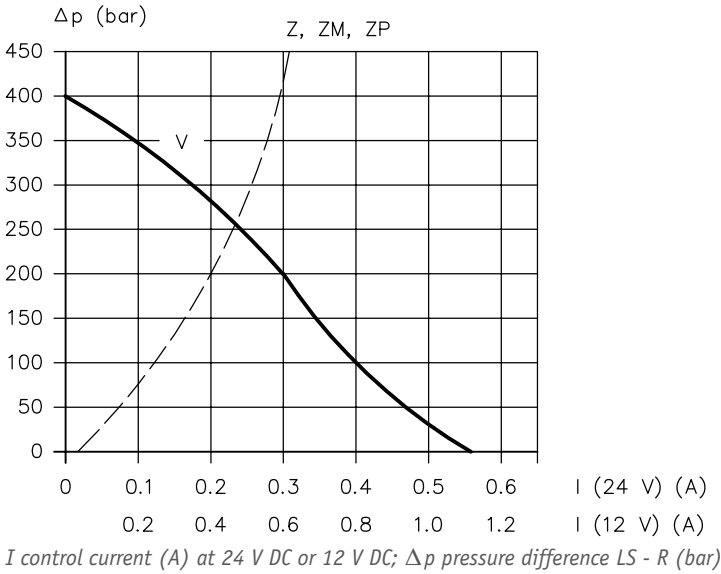

Coding **PA, PB, PD**

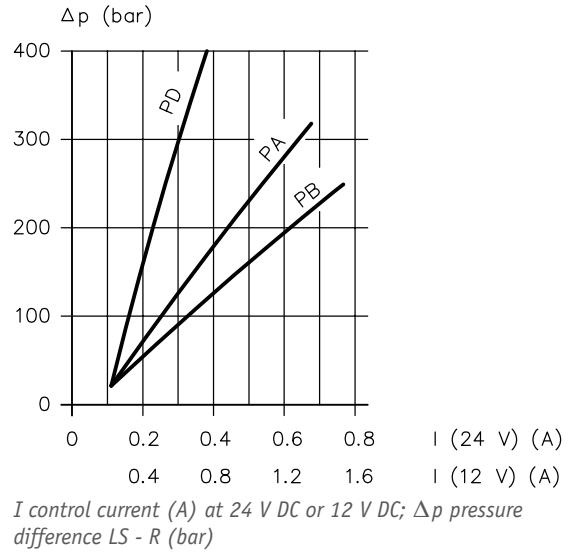

3.4.2 Directional valve section

Pressure difference P → A/B and A/B → R

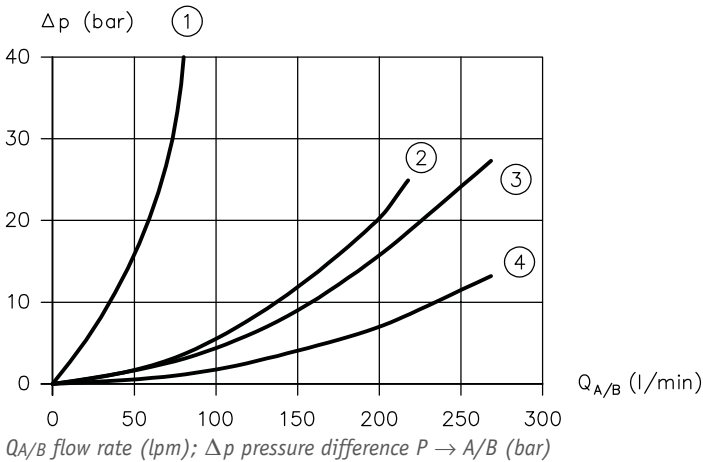

- 1 A/B → R (in neutral position) for spool valve coding H as per Chapter 2.2.1.5
- 2 P → A/B in valve section with 2-way controller code 2, 5 or 7 as per Chapter 2.2.1.2
- 3 P → A/B in valve section without 2-way controller code 1 as per Chapter 2.2.1.2
- 4 A/B → R in spool valve coding L, M, F, H as per Chapter 2.2.1.2

Control characteristic line for consumer flow rate

as per Chapter 2.2.1.6, "Flow rate"

(reference values measured with 2-way controller and standard 2-way controller spring)

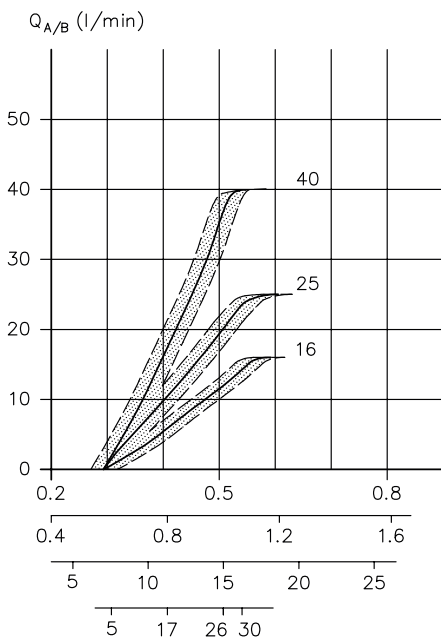

I (24 V) (A)
I (12 V) (A)
p_{hydr.} (bar)
Switching angle (°)

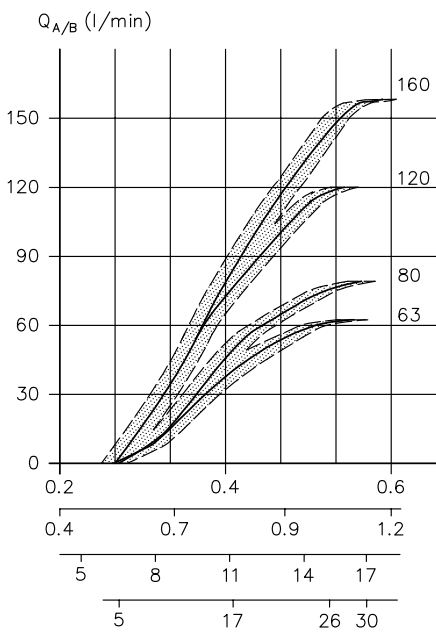

I (24 V) (A)
I (12 V) (A)
p_{hydr.} (bar)
Switching angle (°)

I control current (A) at 24 V DC or 12 V DC for electro-hydraulic actuation

p_{hydr.} Pilot pressure (bar) for hydraulic actuation

Switching angle (°) for manual actuation with hand lever

Q_{A/B} flow rate (lpm)

2-way controller

as per Chapter 2.2.1.2, "Valve section, 2-way controller"

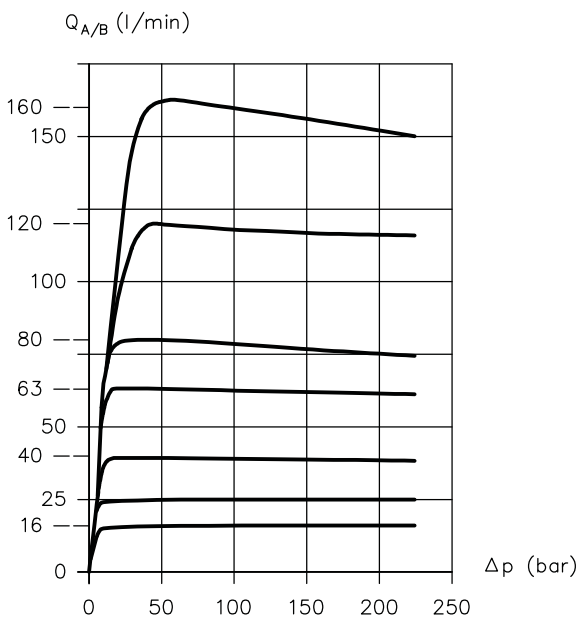

Δp pressure difference P → A/B (bar); Q_{A/B} flow rate (lpm)

LS pressure-limiting valves

as per Chapter 2.2.1.7, "LS pressure limitation"

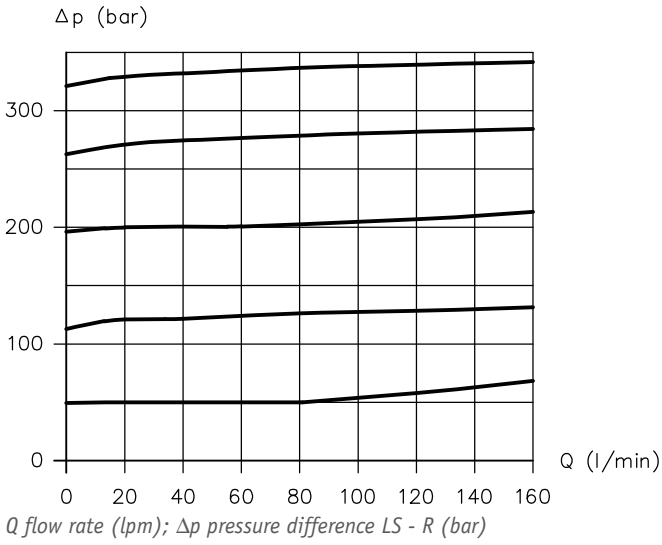

Electro-proportional LS pressure limitation

as per Chapter 2.2.1.8, "Electric LS relief or LS pressure limitation"

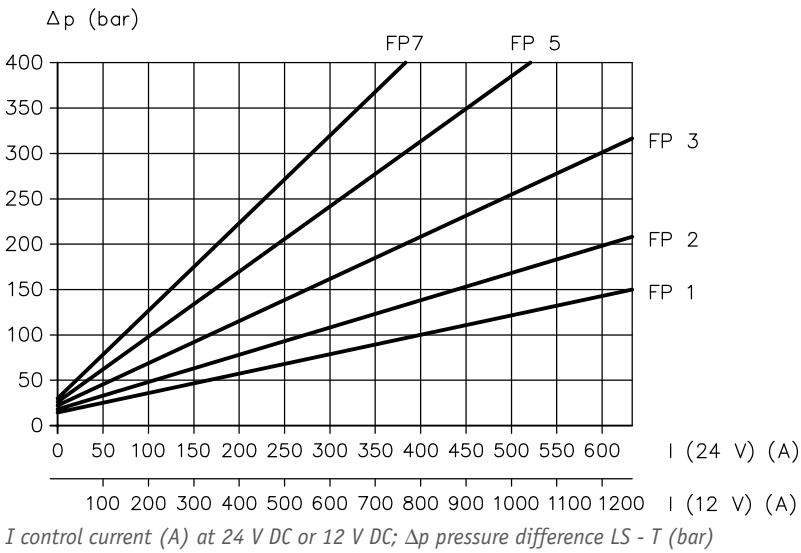

3.5 Electrical data

3.5.1 Electro-hydraulic actuation with standard solenoid

Proportional solenoid, produced and tested in accordance with DIN VDE 0580

Twin solenoid with anchor chambers sealed on the outside and connected to the tank channel. The anchors in the anchor chambers are thereby lubricated by the hydraulic fluid and protected against corrosion without the need for maintenance.

Nominal power U_N	12 V DC	24 V DC
Resistance R_{20}	6.3 Ω	27.0 Ω
Current, cold I_{20}	1.9 A	0.9 A
Limit current I_G	1.26 A	0.63 A
Limit power P_G	15.1 W	15.1 W
Duty cycle	S1 (100%)	
Dither frequency	40 - 70 Hz (recommended value 55 Hz)	
Dither amplitude	$20\% \leq A_D \leq 50\%$	
$AD (\%) = \frac{I_{Spitze-Spitze}}{I_G} \cdot 100$		

I stroke characteristic curve

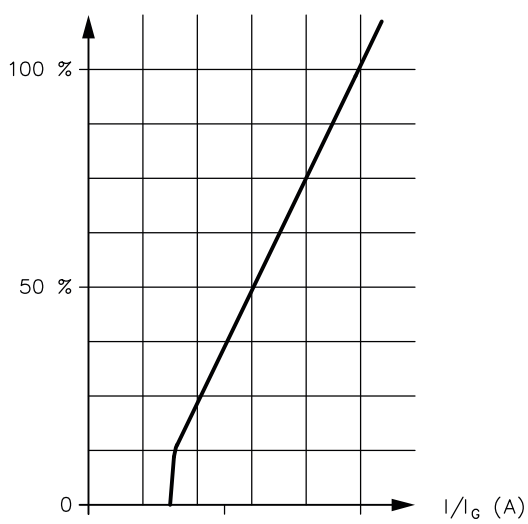

I/I_G control current (A); spool stroke (%)

Ports

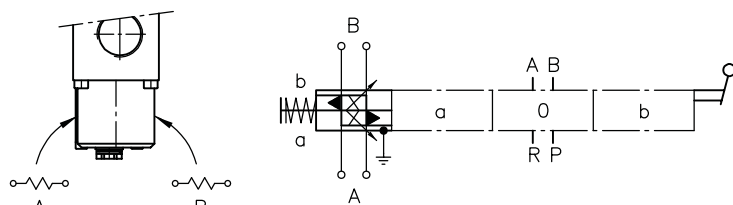

Specifications for A and B

see Table "Electrical connection", "Connection" column

Electrical connection

Coding	Specification	Connection	Plug
AMP 12 (24) K	AMP Junior Timer 3-pin IP 67 (IEC 60529)		
AMP 12 (24) K 4 AMP 12 (24) H 4 AMP 12 (24) H 4 T	AMP Junior Timer 4-pin IP 67 (IEC 60529)		
DT 12 (24) DT 12 (24) T DT 12(24) K	German (DT04 – 4p) 4-pin IP 69k (IEC 60529)		
S 12 (24) S 12 (24) T	Bayonet coupling PA6 Schlemmer 3-pin IP 67 (IEC 60529)		
X 12 (24) G 12 (24) L 12 (24) X 12 (24) T G 12 (24) T L 12 (24) T X 12 (24) TH G 12 (24) TH L 12 (24) TH X 12 (24) DS G 12 (24) DS	EN 175 301-803 A 3-pin IP 65 (IEC 60529)		
X 12 (24) H 4 G 12 (24) H 4 L 12 (24) H 4	EN 175 301-803 A 4-pin IP 65 (IEC 60529)		
X 12 (24) C G 12 (24) C	EN 175 301-803 C 3-pin IP 65 (IEC 60529)		
X 12 (24) C4 G 12 (24) C4	EN 175 301-803 C 3-pin IP 65 (IEC 60529)		
ITT 12 (24)	VG 95234 MIL 4-pin IP 67 (IEC 60529)		
DTL 12 (24) DTL 12 (24) T	MIL-DTL 38999 series III 4-pin IP 67 (IEC 60529)		

3.5.2 Electro-hydraulic actuation with solenoid for potentially explosive atmospheres

! NOTICE

When using solenoids for potentially explosive atmospheres: observe operating instructions [B ATEX](#) and the separate operating instructions for the respective solenoid.

Refer to the applicable operating instructions for operating thresholds, classifications, electrical parameters and electrical connections.

Coding	Operating instructions with declaration of conformity
X 24 TEX 4 70 FM	<ul style="list-style-type: none"> ▪ B ATEX ▪ B 41/2017 (EX23)
G 24 EX G 24 EX-10 m	<ul style="list-style-type: none"> ▪ B ATEX ▪ B 01/2002 (EX01)
G 12 IS G 12 IS-10 m	<ul style="list-style-type: none"> ▪ B ATEX ▪ B 17/2011 (EX05)
G 24 M2FP G 24 M2FP-10 m	<ul style="list-style-type: none"> ▪ B ATEX ▪ B 04/2005 (EX05)
G 24 MSHA G 24 MSHA-10 m G 24 MSHA-20 m	<ul style="list-style-type: none"> ▪ B ATEX ▪ B 04/2005 (EX05)

3.5.3 Switching position monitoring, displacement transducer

Coding WA

Coding	Electrical connection	Protection class (IEC 60529)
WA	EN 175 301-803 A	IP 65
WA-S	Bayonet coupling PA6 Schlemmer	IP 67
WA-AMP	AMP Junior Timer	IP 67
WA-DT	German (DT 04-4P)	IP 69k
WA-C	EN 175 301-803 C	IP 65

Pin assignment:

- 1 = U_{output}
- 2 = $+U_B$ (5 to 10 V)
- 3 = GND
- Earth = not assigned

Sensor assignment:

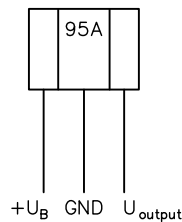

WA

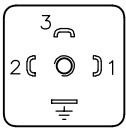

WA-S

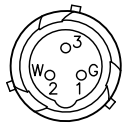

WA-AMP

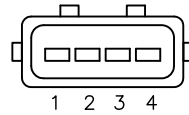

WA-DT

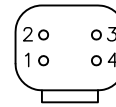

WA-C

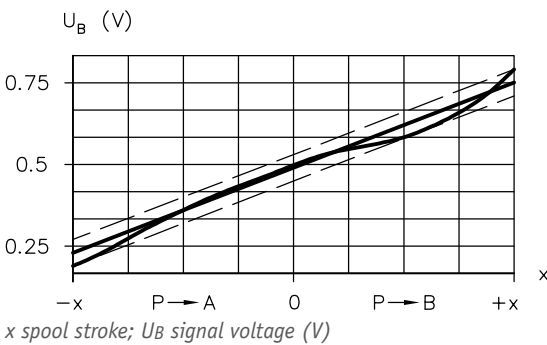
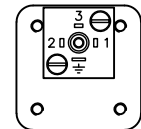

U_B = supply voltage
 $U_{B \text{ max}}$ = 76%
 $U_{B \text{ min}}$ = 24%
 Accuracy $\pm 9\%$ (of U_B)

Use stabilised, smoothed DC voltage only.



NOTICE

The displacement transducer will be destroyed by strong magnetic fields.

Coding U

Protection class IP 65 (IEC 60529)

Pin assignment

Pin	Signal	Description
1	OUTA	PNP positive-switching
2	OUTB	PNP positive-switching
3	+U _B	10 ... 32 V DC
⊕	GND	0 V DC

Open-Collector:
I_{max} = 10 mA
short-circuit-proof

Status table

Running no.	Spool valve action	Signal outputs PNP transistor with open collector:	
		OUTA	OUTB
1	Neutral position in centre	ON	ON
2	P → B	OFF	ON
3	P → A	ON	OFF

U

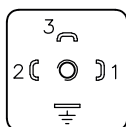

3.5.4 Switching position monitoring, displacement transducer for potentially explosive atmospheres

NOTICE

When using displacement transducers for potentially explosive atmospheres, it is essential to observe the operating instructions [B ATEX](#) and the separate operating instructions for the respective displacement transducer. Refer to the applicable operating instructions for operating thresholds, classifications, electrical parameters and electrical connections.

Coding	Operating instructions with declaration of conformity
WA-EX	<ul style="list-style-type: none"> B ATEX B 10/2008 (EX09)
WA-M2FP	<ul style="list-style-type: none"> B ATEX B 10/2008 (EX09)
WA-IS	<ul style="list-style-type: none"> B ATEX B 31/2013 (EX16)
WA-MSHC	<ul style="list-style-type: none"> B ATEX B 10/2008 (EX09)

3.5.5 Electric LS relief or LS pressure limitation

Electric LS relief coding F 1, F 2, F 3, FH 1, FH 2, FH 3

Nominal voltage U_N	12 V DC	24 V DC
Resistance R_{20}	8.7 Ω	34.8 Ω
Current, cold I_{20}	1.38 A	0.69 A
Limit current I_G	0.97 A	0.48 A
Limit power P_G	11.6 W	11.6 W
Duty cycle	S1 (100%)	

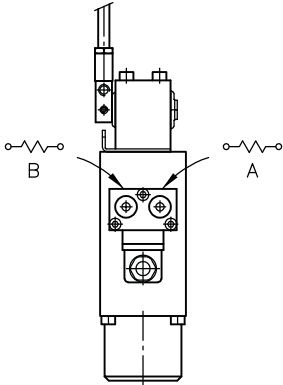

For specifications for **A** and **B** see Table “Electrical connection”, “Connection” column.

NOTICE
Duty cycle applies separately for a single twin solenoid coil. If both coils are powered simultaneously, only 50% is permitted as duty cycle.

NOTICE
The electrical LS relief’s on/off twin solenoids are only available with DIN connectors and manual override (coding -G..T(H), -X..T(H) or -L..T(H)).

Electrical connection

Coding	Specification	Connection	Plug
X 12 (24) T G 12 (24) T L 12 (24) T X 12 (24) TH G 12 (24) TH L 12 (24) TH	EN 175 301-803 A 3-pin IP 65 (IEC 60529)		

Electro-proportional LS pressure limitation coding FP.., FPH..

Nominal voltage U_N	12 V DC	24 V DC
Resistance R_{20}	6.3 Ω	27.0 Ω
Current, cold I_{20}	1.9 A	0.9 A
Limit current I_G	1.26 A	0.63 A
Limit power P_G	15.1 W	15.1 W
Duty cycle	S1 (100%)	
Dither frequency	40 - 70 Hz (recommended value 55 Hz)	
Dither amplitude	$20\% \leq A_D \leq 50\%$	
$AD (\%) = \frac{I_{Spitze} - I_{Spitze}}{I_G} \cdot 100$		

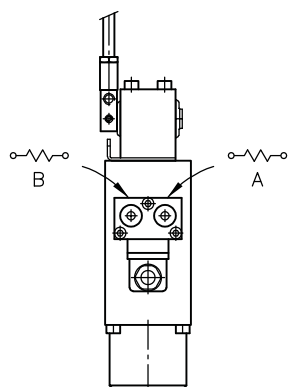

For specifications for **A** and **B** see Table "Electrical connection", "Connection" column

Electrical connection

Coding	Specification	Connection	Plug
AMP 12 (24) H 4 T	AMP Junior Timer 4-pin IP 67 (IEC 60529)		
DT 12 (24) T DT 12 (24) TH	German (DT04 - 4p) 4-pin IP 69k (IEC 60529)		
S 12 (24) T	Bayonet coupling PA6 Schlemmer 3-pin IP 67 (IEC 60529)		
X 12 (24) T G 12 (24) T L 12 (24) T X 12 (24) TH G 12 (24) TH L 12 (24) TH	EN 175 301-803 A 3-pin IP 65 (IEC 60529)		

NOTICE

Duty cycle applies separately for a single twin solenoid coil. If both coils are powered simultaneously, only 50% is permitted as duty cycle.

NOTICE

- Only twin solenoids with manual override (coding T or -TH) are possible.
- If a twin solenoid without manual override was chosen for the valve section's electro-hydraulic actuation, the same twin solenoid type is automatically used for the LS pressure limitation's electro-proportional actuation, but with additional manual override.
- If the twin solenoid type is not possible with manual override, coding -G..T is used by default.

3.5.6 Electric LS relief or LS pressure limitation for potentially explosive atmospheres

NOTICE

When using solenoids for potentially explosive atmospheres, it is essential to observe the operating instructions [B ATEX](#) and the separate operating instructions for the respective solenoid.

Refer to the applicable operating instructions for operating thresholds, classifications, electrical parameters and electrical connections.

Coding	Operating instructions with declaration of conformity
X 24 TEX 4 70 FM	<ul style="list-style-type: none"> B ATEX B 41/2017 (EX23)

3.5.7 Additional valves

The types of plugs available are described in [Chapter 2.5, "Solenoid voltage and solenoid version"](#). Refer to the respective additional valve's data sheet for electrical parameters.

4 Dimensions

All dimensions in mm, subject to change.

4.1 Connection block

see Chapter 2.1.4, "Connection block basic types"

PSL 5.../...-5

PSL 6.../...-5

PSL 6 UNF.../...-5

PSL JIS 5.../...-5

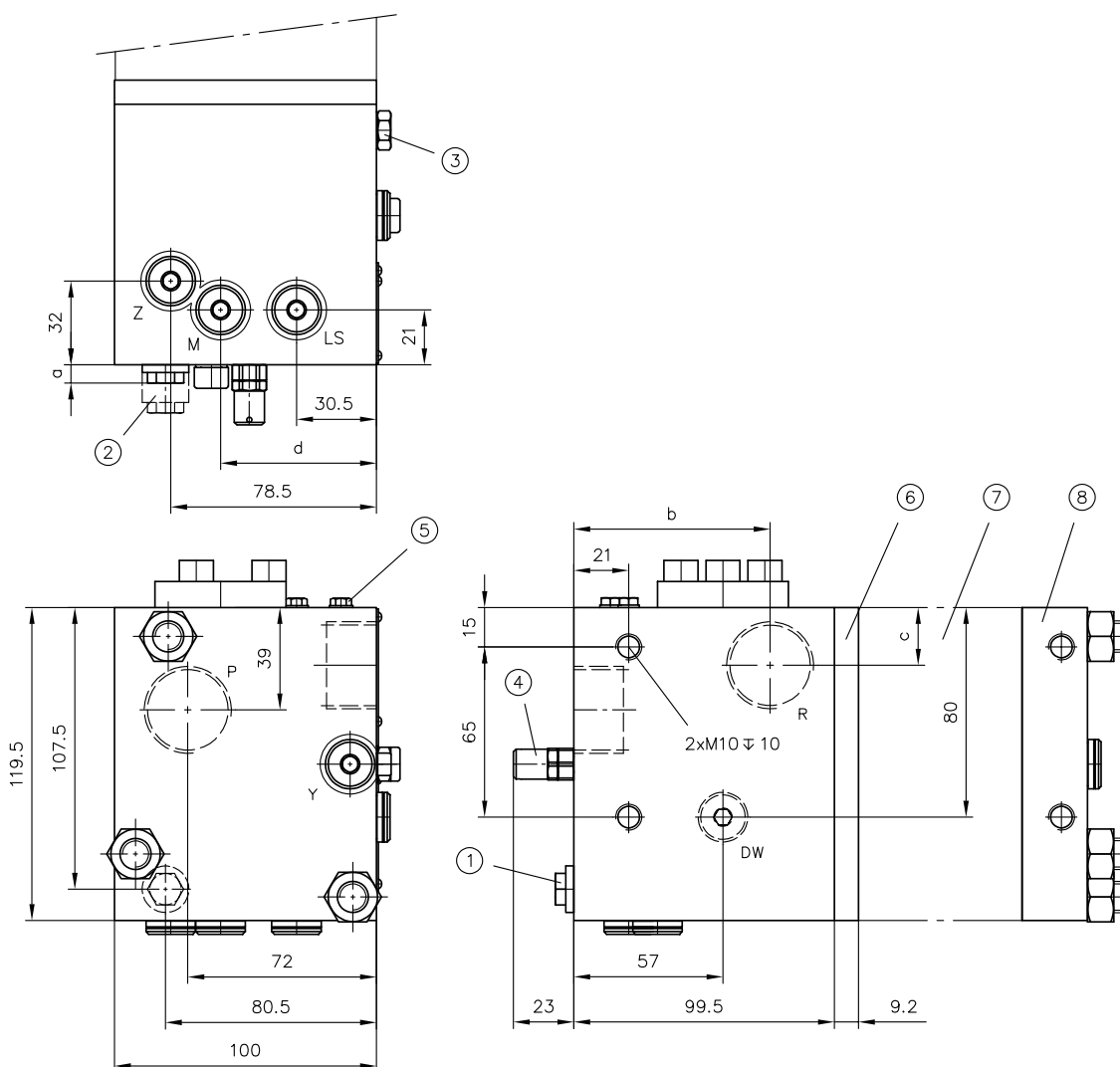

- 1 Internal control oil supply without coding or coding 1
- 2 Internal control oil supply coding 2
- 3 LS damping
- 4 Pressure-limiting valve
- 5 Mounting point for additional valve for LS relief or LS pressure limitation
- 6 Intermediate plate ZPL 55/9
- 7 Valve section
- 8 End plate

Coding	a	Type	b	c	d	Ports (ISO 228-1 or SAE J 514)	
						Z, M, LS, DW	R, P
without coding	6,5						
1	6,5	PSL 5.../...-5	75	22	59,5	G 1/4	G 1
2	18,4	PSL 6.../...-5	73,5	26	59,5	G 1/4	G 1 1/4
		PSL UNF 6.../...-5	66	26	59,5	7/16-20 UNF-2B (SAE-4)	1 5/8-12 UN-2B (SAE-20)
		PSL JIS 5.../...-5	75	22	56	G 1/4	G 1

PSL 5 U.../...-5

PSL 6 U.../...-5

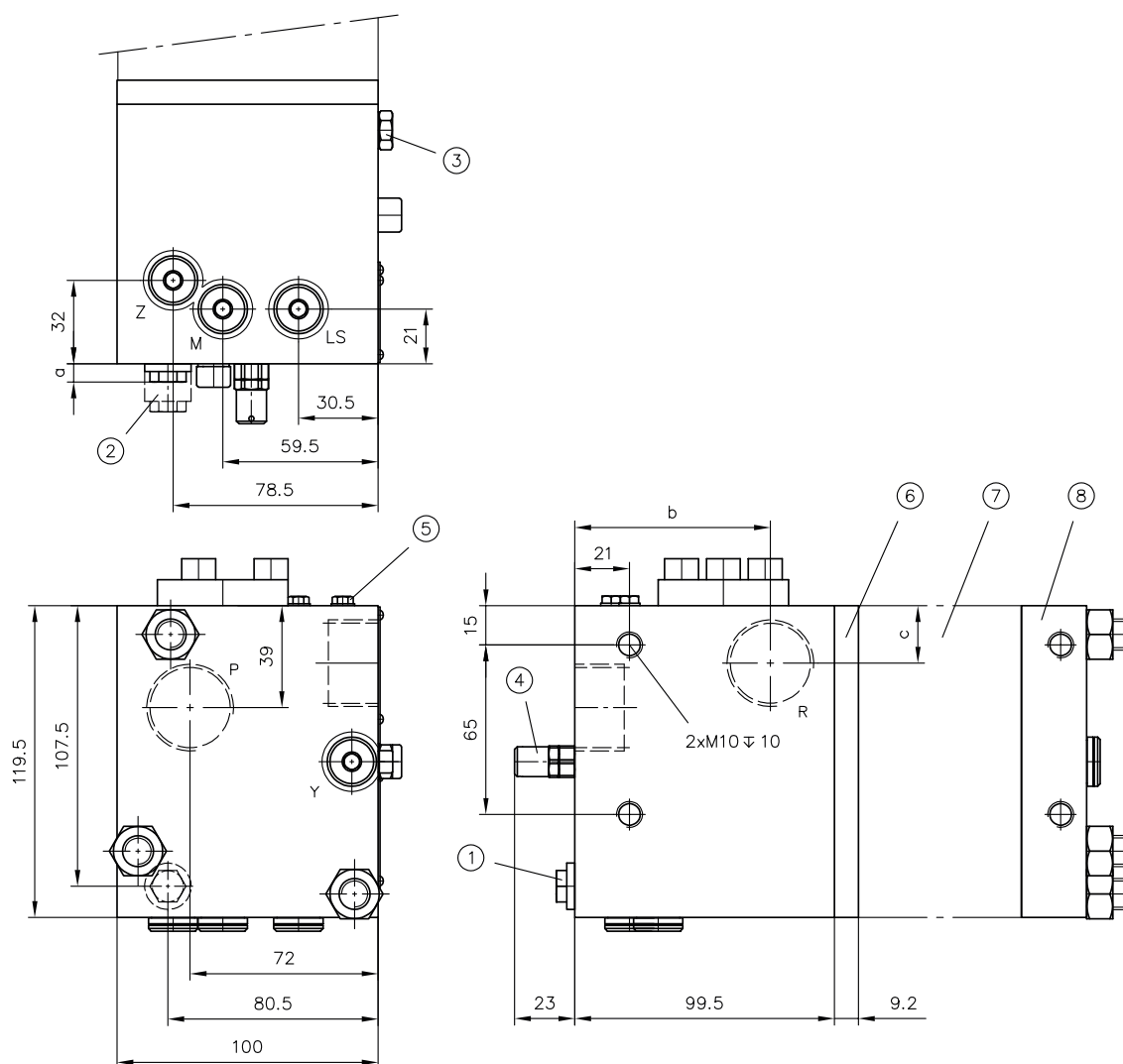

- 1 Internal control oil supply without coding or coding 1
- 2 Internal control oil supply coding 2
- 3 LS damping
- 4 Pressure-limiting valve
- 5 Mounting point for additional valve for LS relief or LS pressure limitation
- 6 Intermediate plate ZPL 55/9
- 7 Valve section
- 8 End plate

Coding	a	Type	b	c	Ports (ISO 228-1)	
					Z, M, LS	R, P
without coding	6,5					
1	6,5	PSL 5 U.../...-5	75	22	G 1/4	G 1
2	18,4	PSL 6 U.../...-5	73,5	26	G 1/4	G 1 1/4

PSL 6 UC22 2/...-5

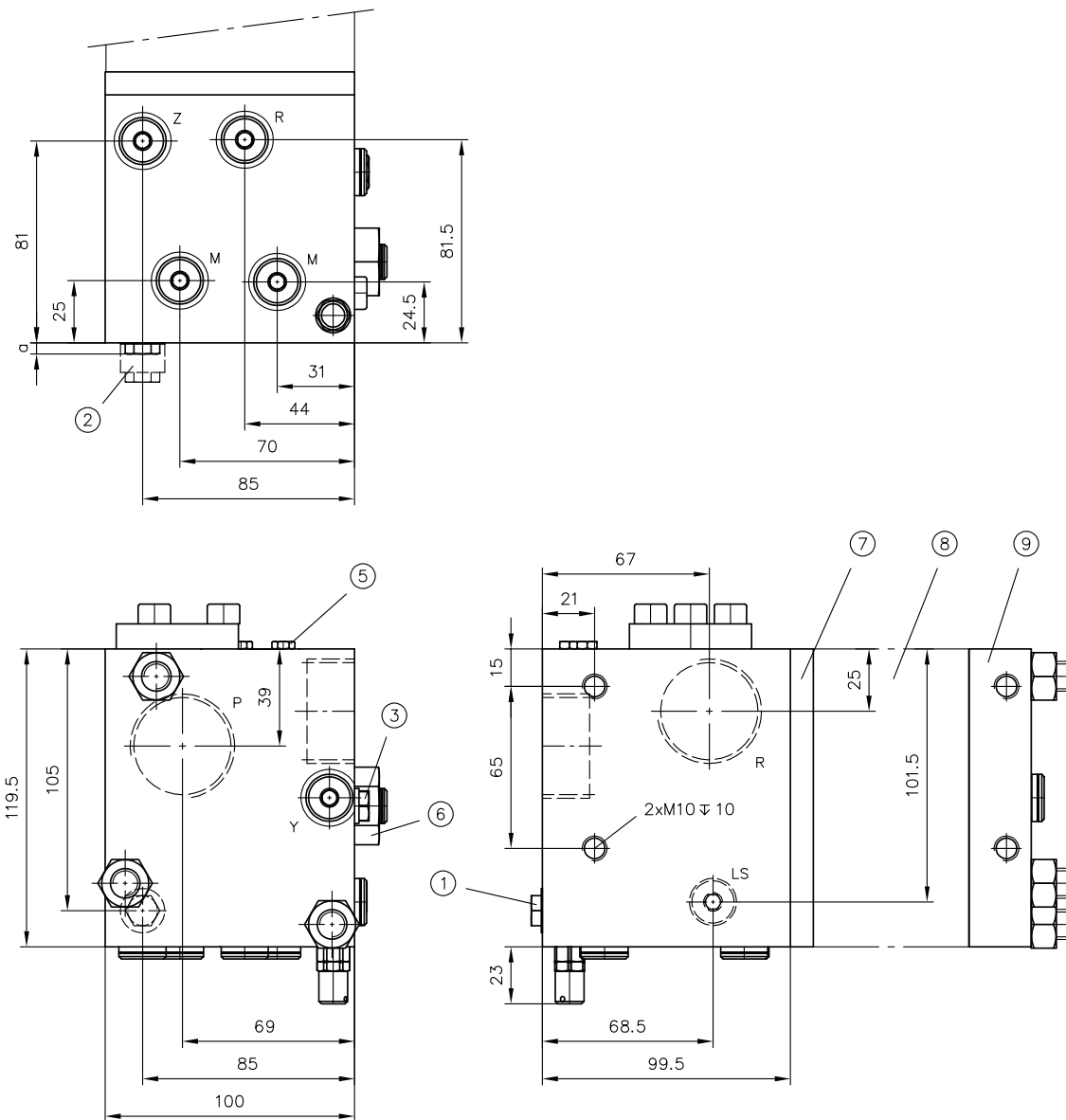

- 1 Internal control oil supply without coding or coding 1
- 2 Internal control oil supply coding 2
- 3 LS damping
- 4 Pressure-limiting valve
- 5 Mounting point for additional valve for LS relief or LS pressure limitation
- 6 Idle circulation valve
- 7 Intermediate plate ZPL 55/9
- 8 Valve section
- 9 End plate

Coding	a	Type	Ports (ISO 228-1)	
without coding	3,9	PSL 6 UC22 2.../...-5	Z, M, LS, R	R, P
1	3,9		G 1/4	G 1 1/4
2	15,8			

PSL 6 Y.../...-5

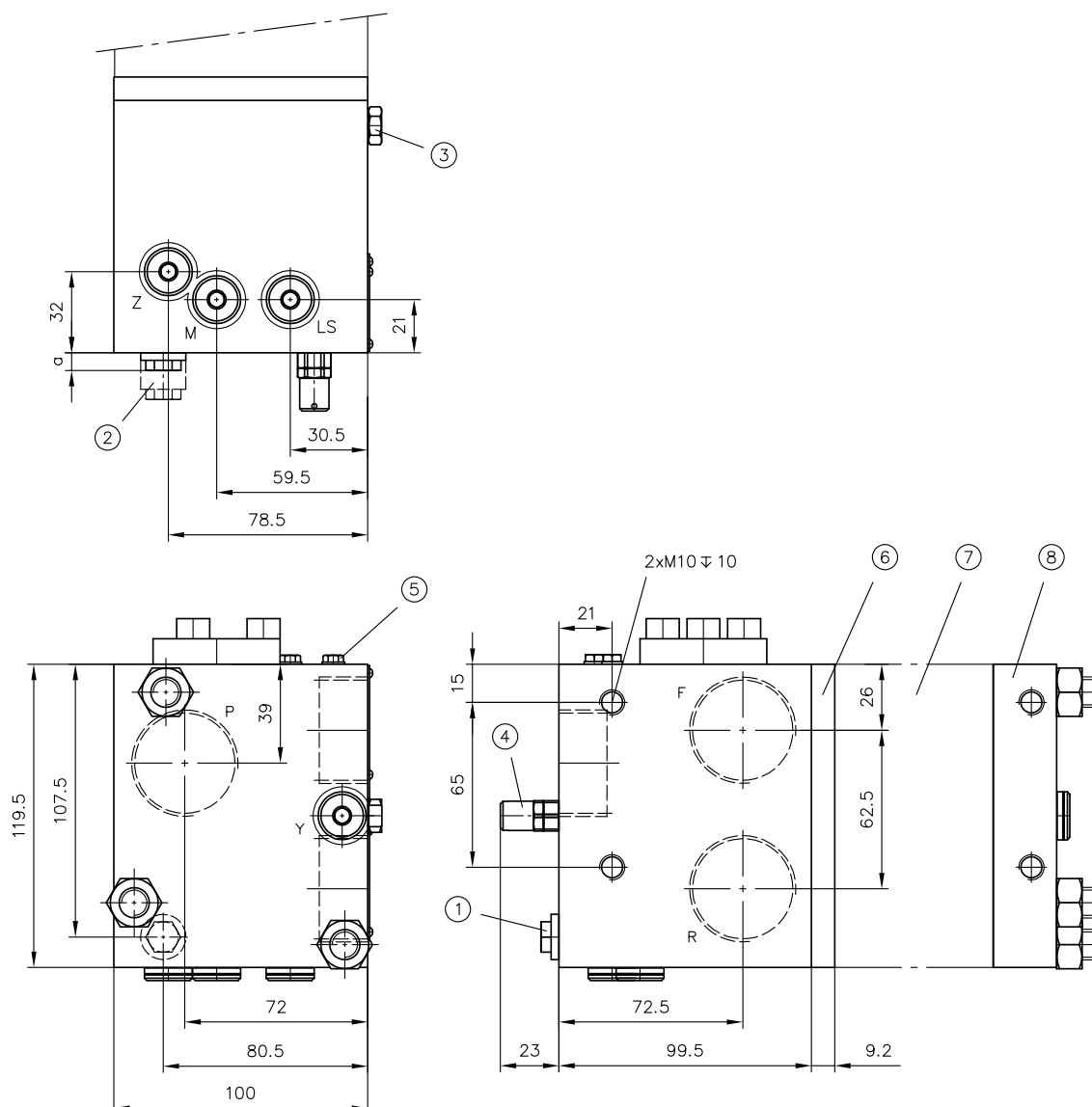

- 1 Internal control oil supply without coding or coding 1
- 2 Internal control oil supply coding 2
- 3 LS damping
- 4 Pressure-limiting valve
- 5 Mounting point for additional valve for LS relief or LS pressure limitation
- 6 Intermediate plate ZPL 55/9
- 7 Valve section
- 8 End plate

Coding	a	Type	Ports (ISO 228-1)	
			Z, M, LS	R, P, F
without coding	6,5	PSL 6 Y.../...-5	Z, M, LS	R, P, F
1	6,5		G 1/4	G 1 1/4
2	18,4			

PSV 5...-5
PSV 6...-5
PSV UNF 6...-5

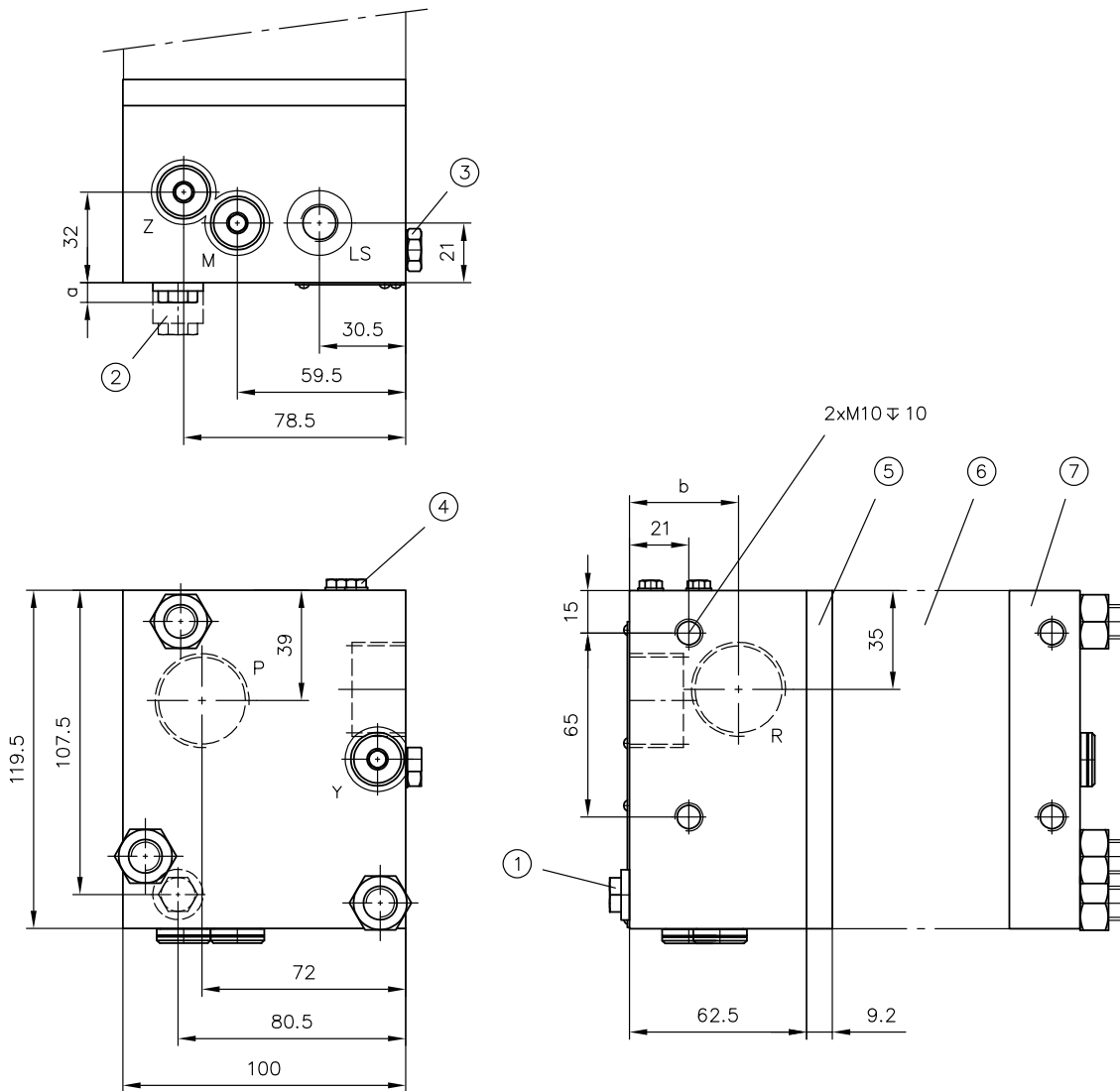

- 1 Internal control oil supply without coding or coding 1
- 2 Internal control oil supply coding 2
- 3 LS damping
- 4 Mounting point for additional valve for LS relief or LS pressure limitation
- 5 Intermediate plate ZPL 55/9
- 6 Valve section
- 7 End plate

Coding	a	Type	b	Ports (ISO 228-1 or SAE J 514)	
				Z, M, LS	R, P
without coding	6,5				
1	6,5	PSV 5...-5	38,5	G 1/4	G 1
2	18,4	PSV 6...-5	38,5	G 1/4	G 1 1/4
		PSV UNF 6...-5	33,5	7/16-20 UNF-2B (SAE-4)	1 5/8-12 UN-2B (SAE-20)

PSV 5.../...-5
 PSV 6.../...-5
 PSV UNF 6.../...-5

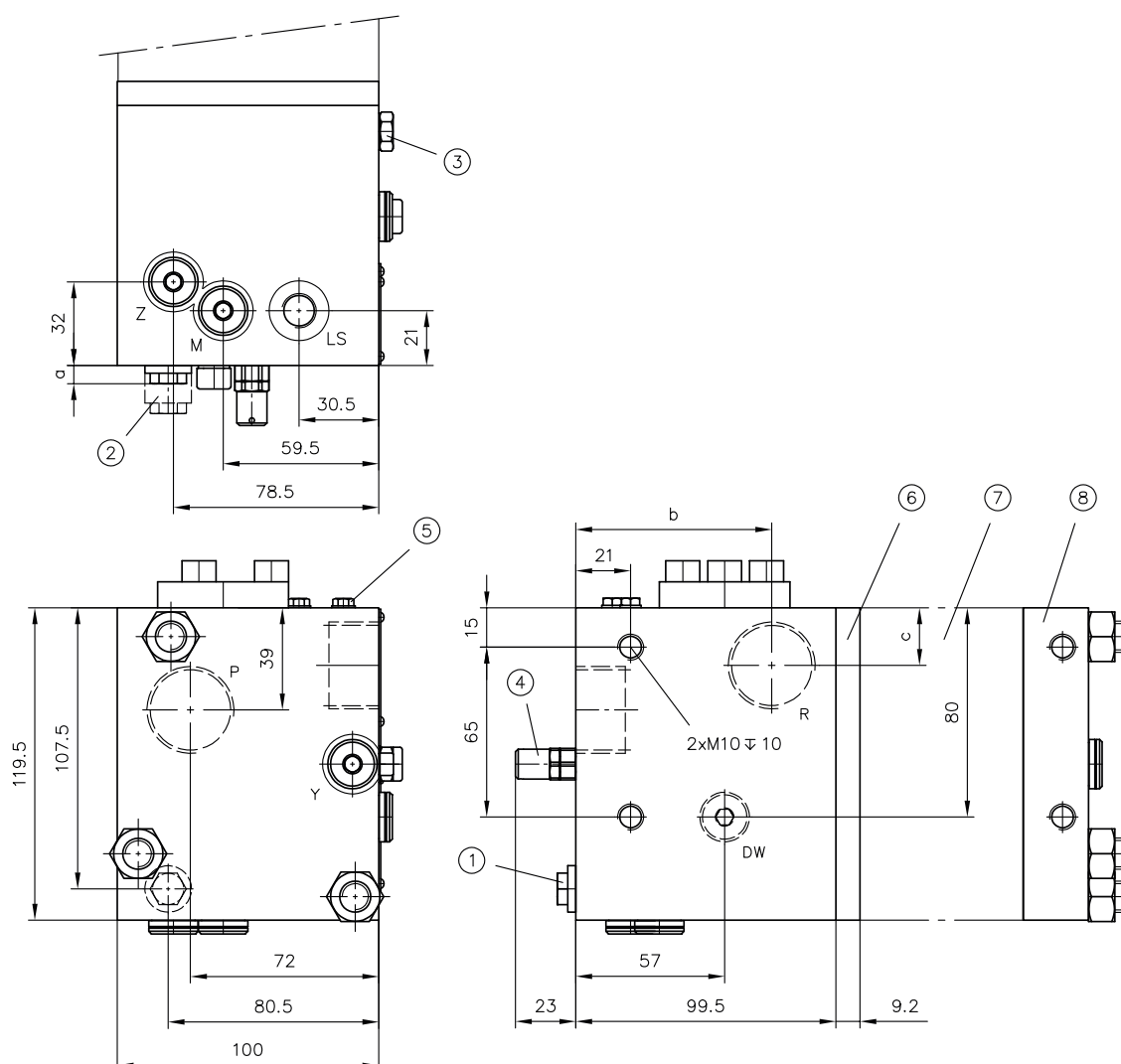

- 1 Internal control oil supply without coding or coding 1
- 2 Internal control oil supply coding 2
- 3 LS damping
- 4 Pressure-limiting valve
- 5 Mounting point for additional valve for LS relief or LS pressure limitation
- 6 Intermediate plate ZPL 55/9
- 7 Valve section
- 8 End plate

Coding	a	Type	b	c	Ports (ISO 228-1 or SAE J 514)	
					Z, M, LS, DW	R, P
without coding	6,5					
1	6,5	PSV 5.../...-5	75	22	G 1/4	G 1
2	18,4	PSV 6.../...-5	73,5	26	G 1/4	G 1 1/4
		PSV UNF 6.../...-5	66	26	7/16-20 UNF-2B (SAE-4)	1 5/8-12 UN-2B (SAE-20)

PSV 5 N.../.../...-5
PSV UNF 5 N.../.../...-5

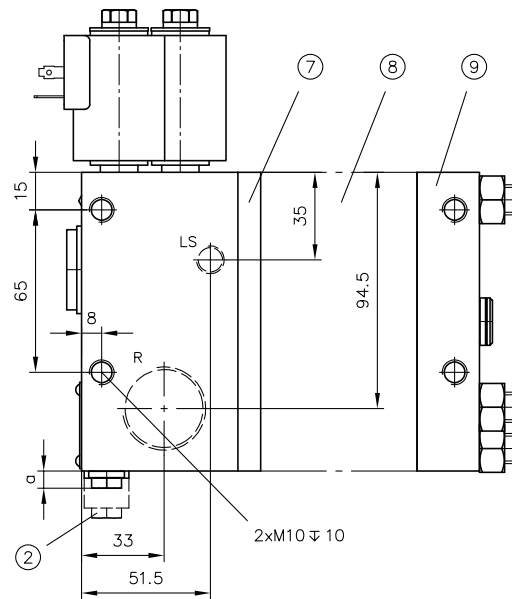
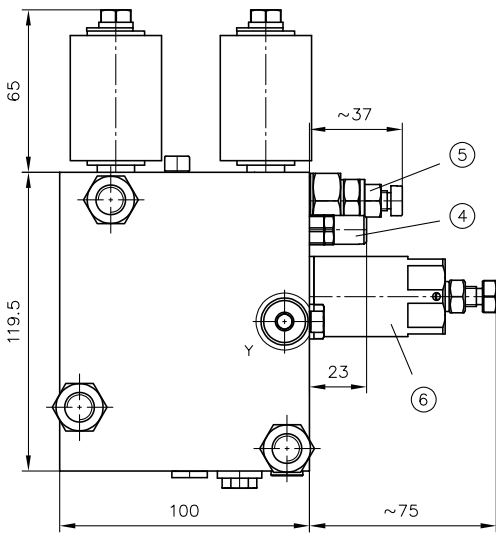
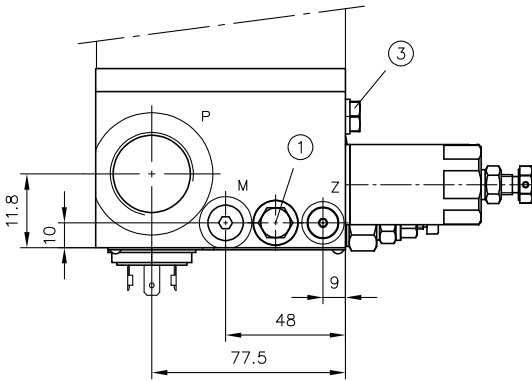

- 1 Internal control oil supply without coding or coding 1
- 2 Internal control oil supply coding 2
- 3 LS damping
- 4 Pressure-limiting valve
- 5 2-way flow control valve CSJ
- 6 Pressure-limiting valve MVJ 6
- 7 Intermediate plate ZPL 55/9
- 8 Valve section
- 9 End plate

Coding	a
without coding	6,5
1	6,5
2	18,4

Type	Ports (ISO 228-1 or SAE J 514)		
	M, LS	R, P	Z
PSL 5 N.../.../...-5	G 1/4	G 1 1/4	G 1/8
PSV UNF 5 N.../.../...-5	7/16-20 UNF-2B (SAE-4)	1 5/16-12 UN-2B (SAE-16)	5/16-24 UNF-2B (SAE-2)

PSM 5.../...-5
PSM UNF 6.../...-5

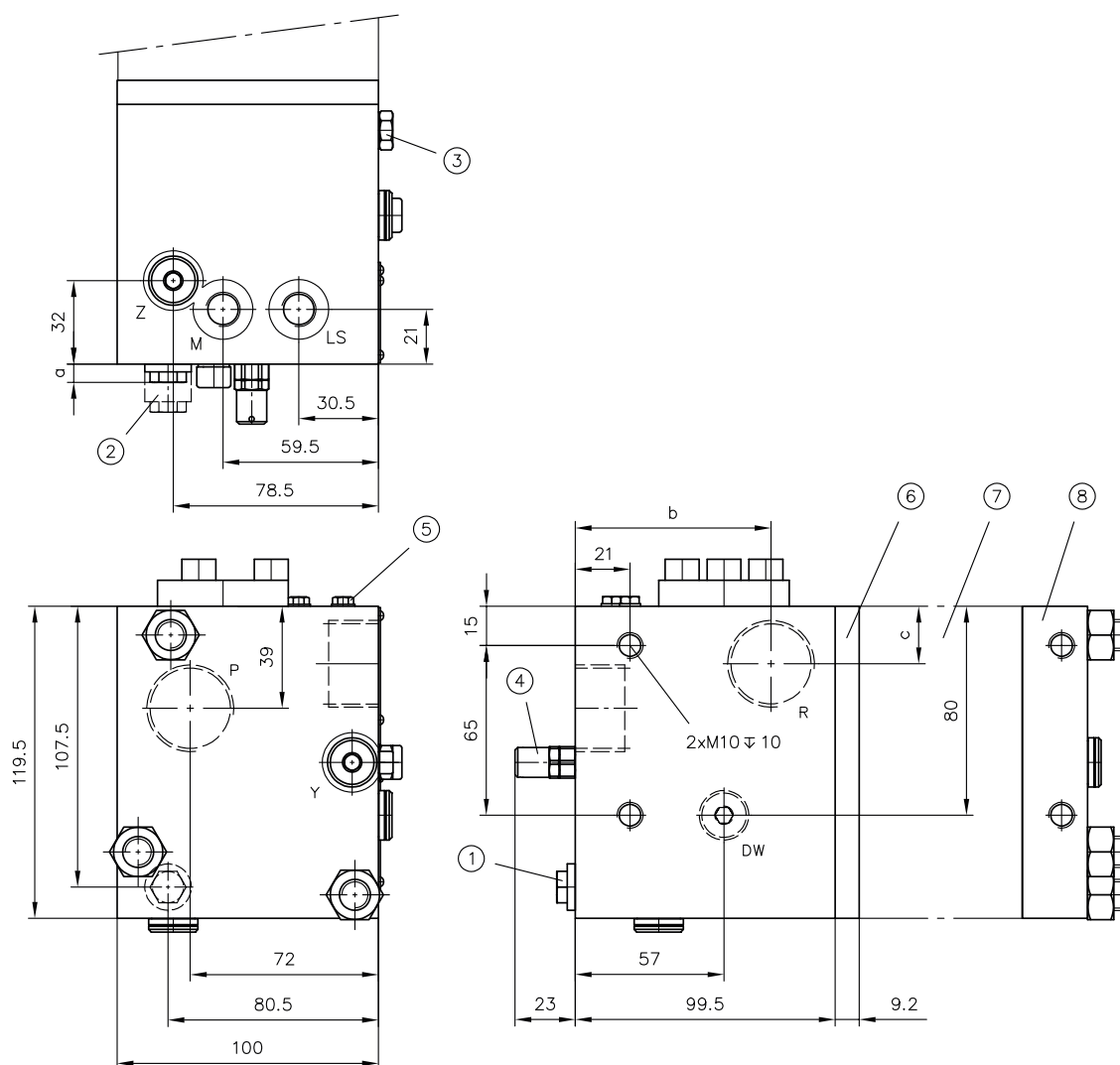

- 1 Internal control oil supply without coding or coding 1
- 2 Internal control oil supply coding 2
- 3 LS damping
- 4 Pressure-limiting valve
- 5 Mounting point for additional valve for LS relief or LS pressure limitation
- 6 Intermediate plate ZPL 55/9
- 7 Valve section
- 8 End plate

Coding	a	Type	b	c	Ports (ISO 228-1 or SAE J 514)	
					Z, M, LS, DW	R, P
without coding	6,5					
1	6,5	PSM 5.../...-5	75	22	G 1/4	G 1
2	18,4	PSM 6.../...-5	73,5	26	G 1/4	G 1 1/4
		PSM UNF 6.../...-5	66	26	7/16-20 UNF-2B (SAE-4)	1 5/8-12 UN-2B (SAE-20)

Additional valves for LS relief or LS pressure limitation on connection block

see Chapter 2.1.8, "LS relief or LS pressure limitation"

without coding



Coding X

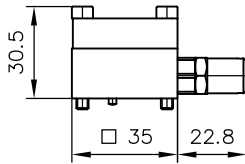

Coding VX

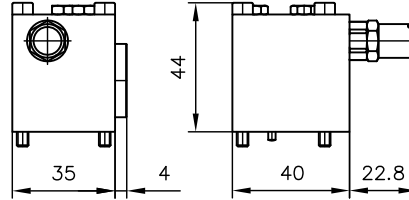

Coding F, D

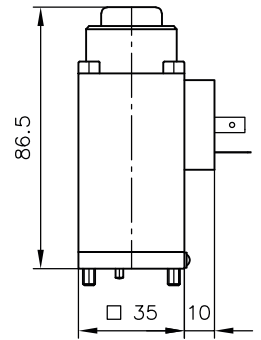

Coding F..., D...

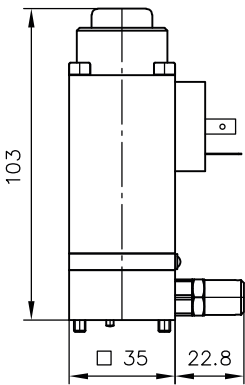

Coding F BVE, D BVE

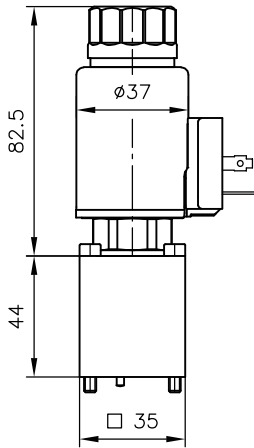

Coding V, Z

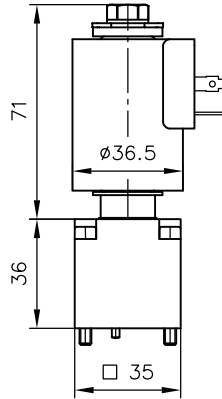

Coding ZM

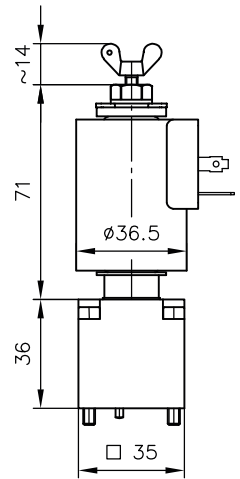

Coding ZP

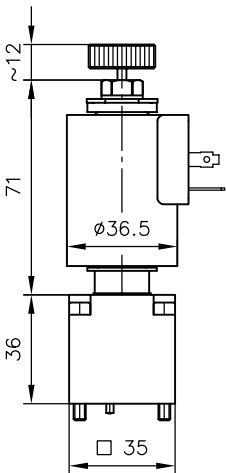

Coding VA, ZA

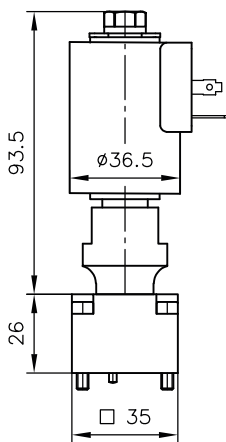

Coding ZAM

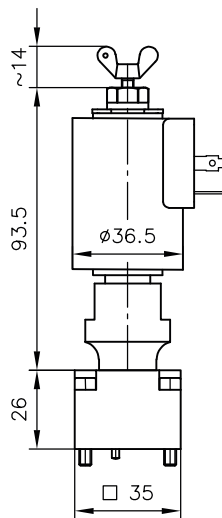

Coding ZAP

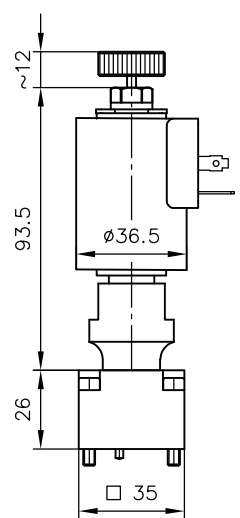

Coding **VD, ZD**

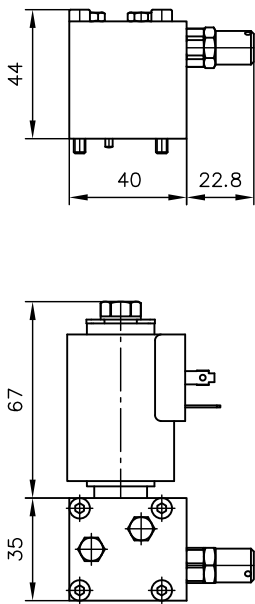

Coding **ZDM**

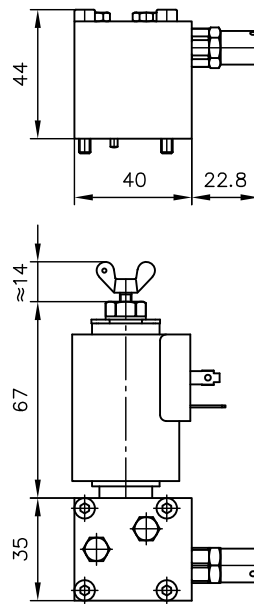

Coding **ZDP**

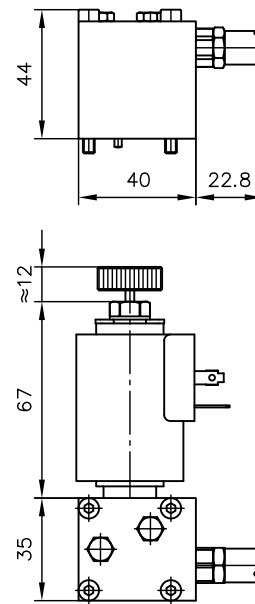

Coding **PA, PB, PC, PD**

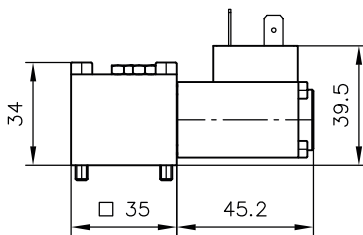

Coding **Z ADM..**

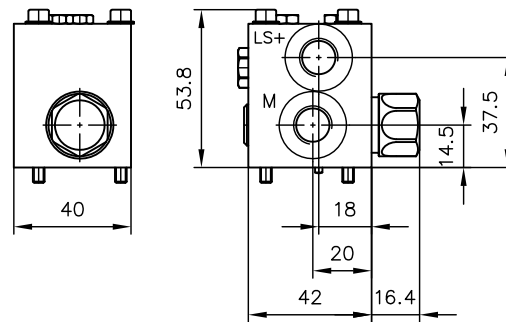

Coding **X9**

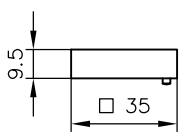

Coding **X18**

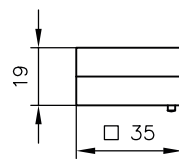

Coding **X27**

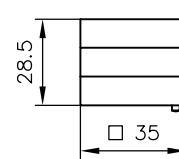

4.2 Valve section

4.2.1 Directional valve section

4.2.1.1 With integrated ports

(coding 5, UNF 5 as per Chapter 2.2.1.1, "Consumer ports")

Coding 5, UNF 5

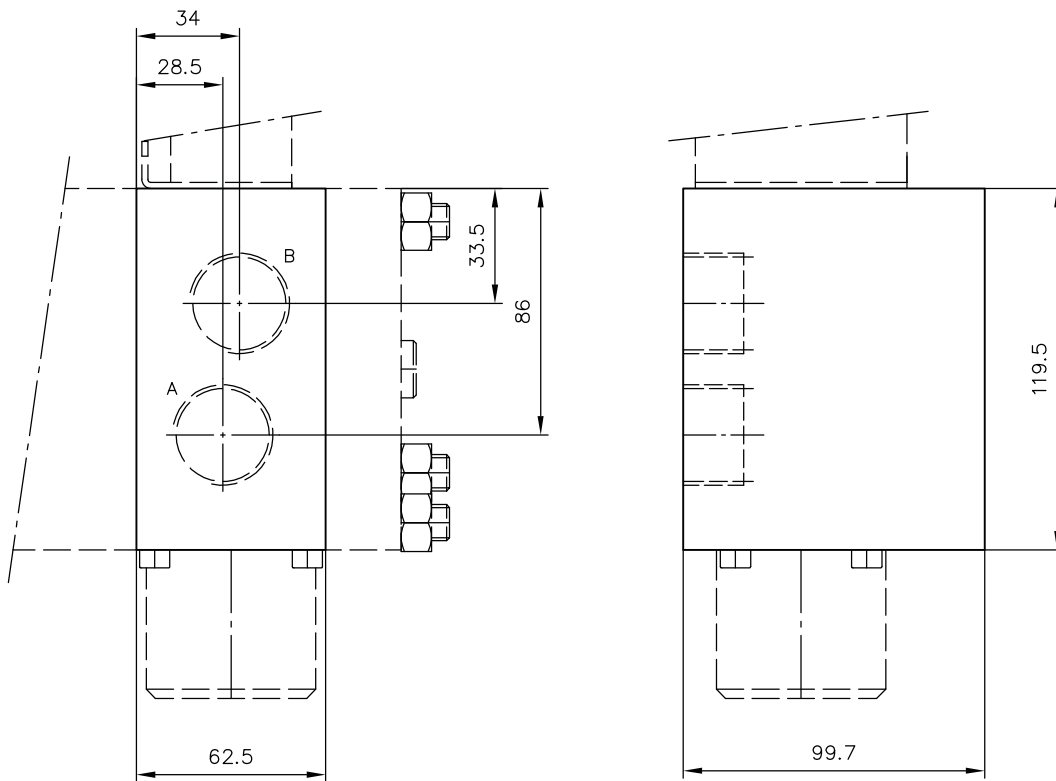

Coding	Ports (ISO 228-1 or SAE J 514)
	A, B
5	G 1
UNF 5	1 5/16-12 UN-2B (SAE-16)

4.2.1.2 For combination with an ancillary block

(coding A as per Chapter 2.2.1.1, "Consumer ports")

Coding A

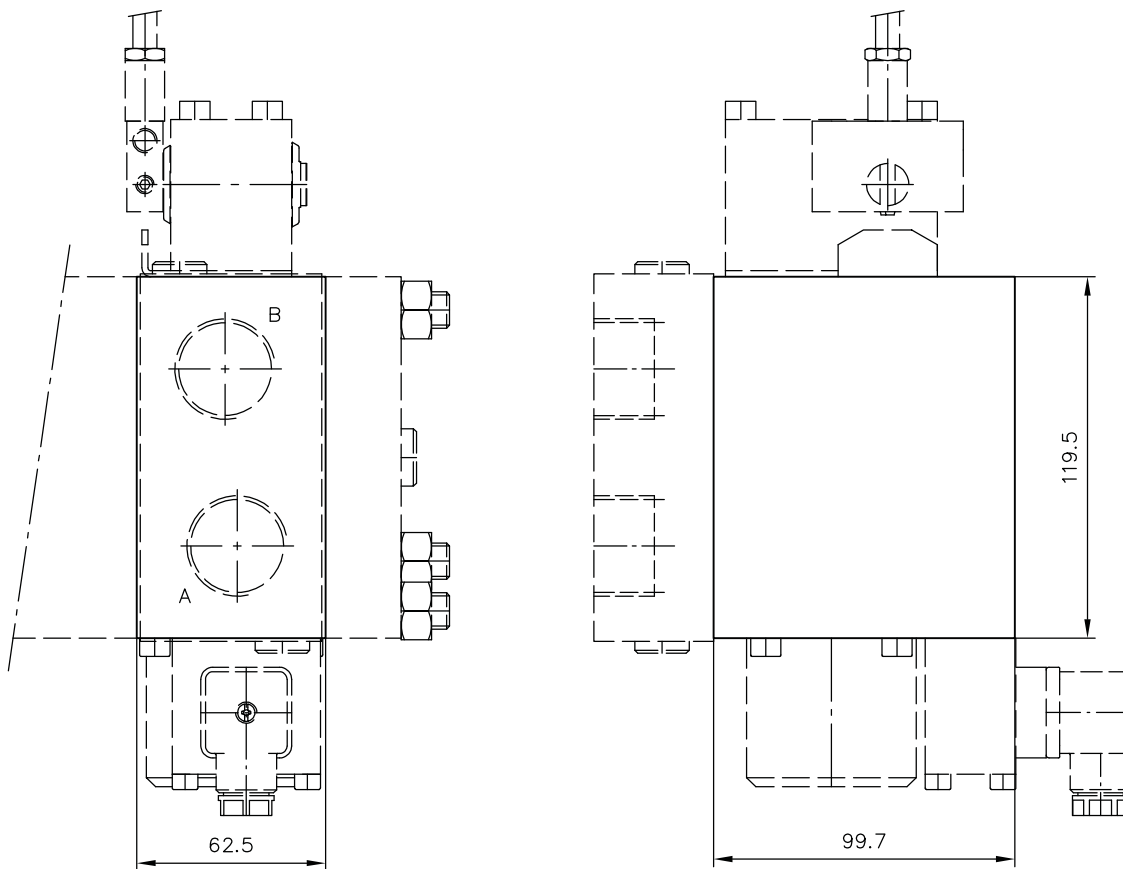

4.2.1.3 Pre-selector valve with integrated ports

(coding 8, 81, UNF 8, UNF 81 as per Chapter 2.2.1.2, "Valve section, 2-way controller")

Coding **8, 81**

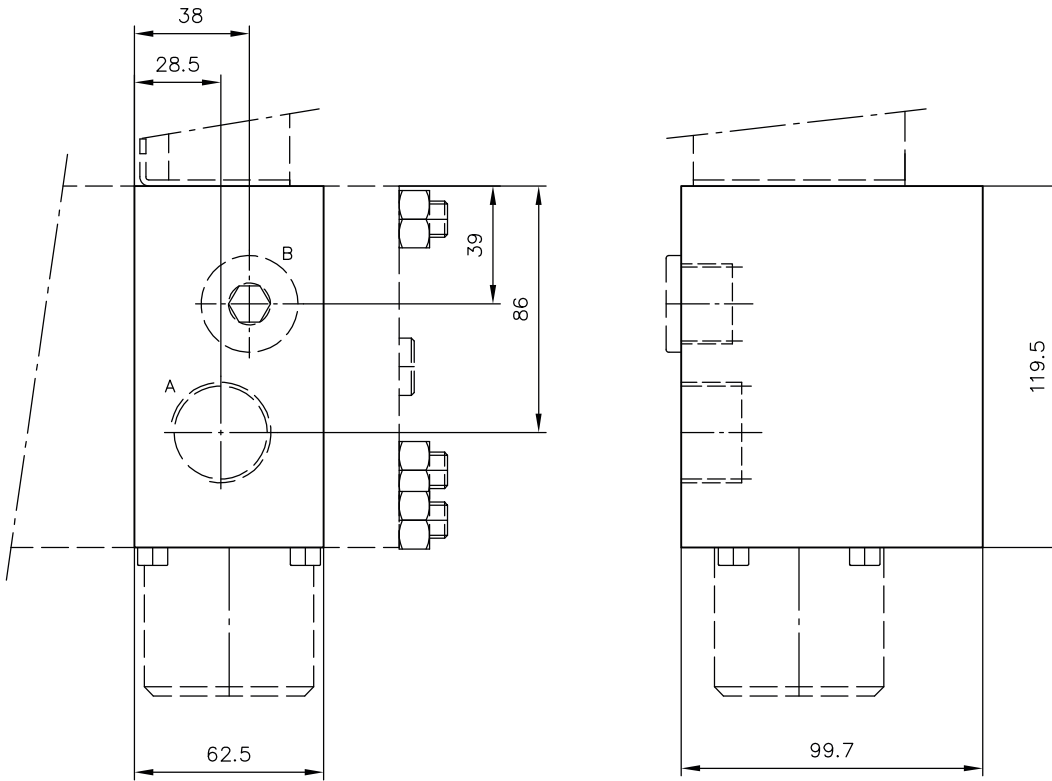

Coding

Ports (ISO 228-1)

	Ports (ISO 228-1)	
	A	B
8, 81	G 1	G 3/4

Coding **UNF 8, UNF 81**

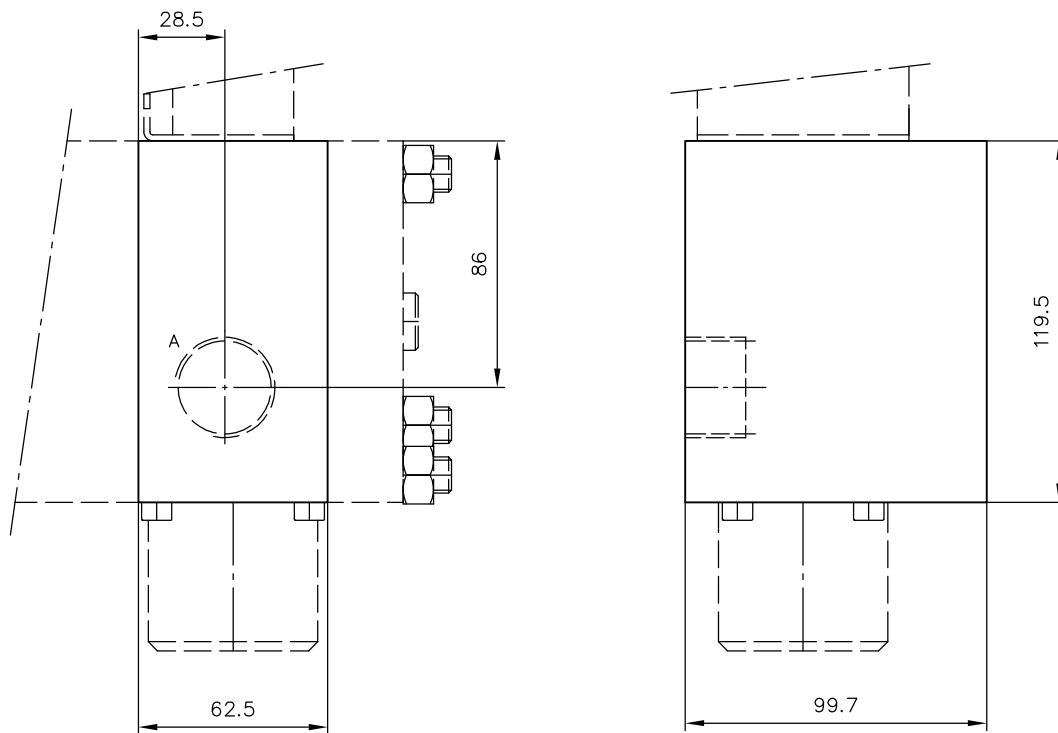

Coding

Ports (SAE J 514)

A

UNF 8, UNF 81

1 5/16-12 UN-2B (SAE-16)

4.2.1.4 With manual actuation

Actuation A, C

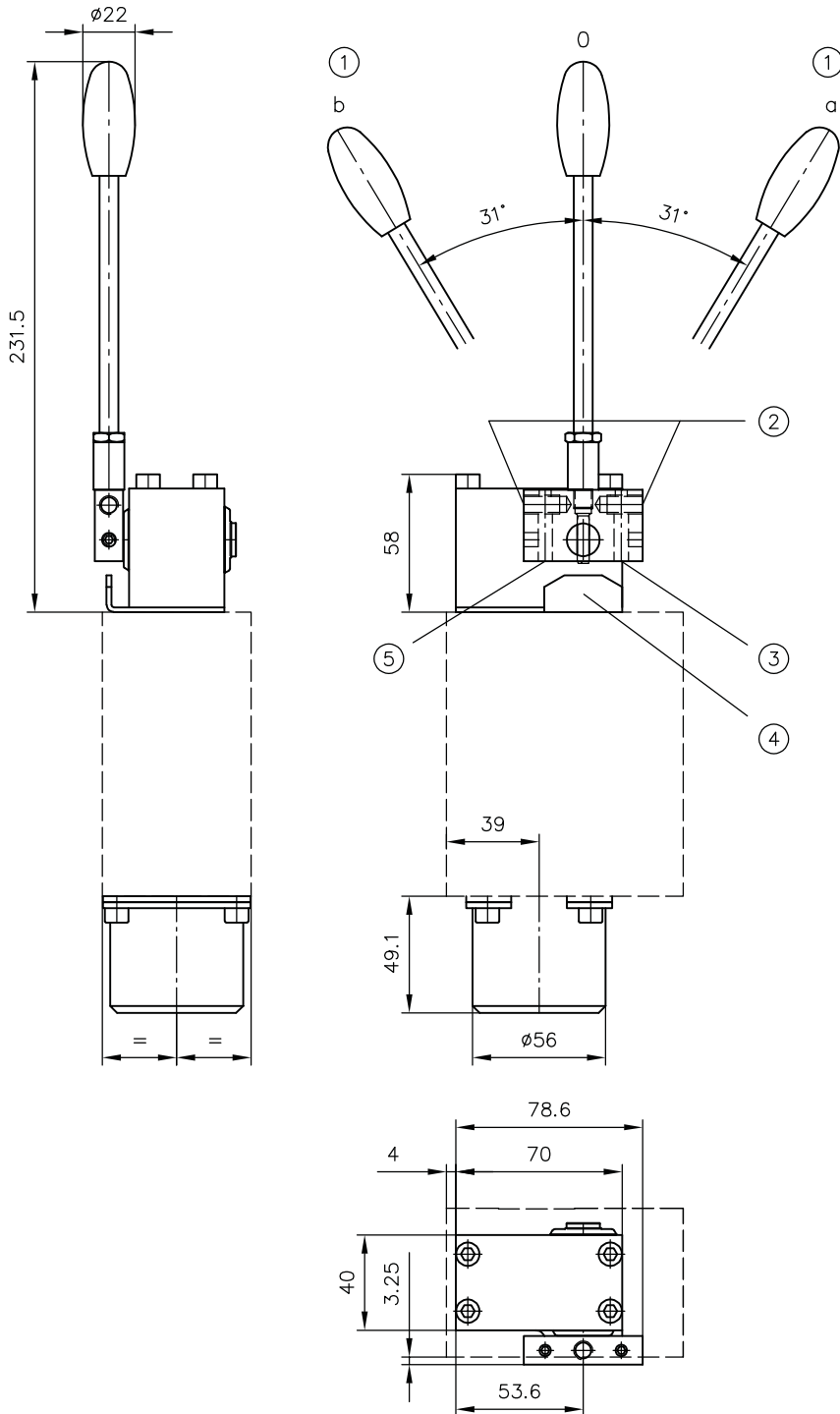

- 1 Switching position 0, a and b
- 2 Hand lever can also be mounted here, thread M8, 15 deep. This lever position cannot be used in combination with ancillary blocks.
- 3 Travel stop for flow rate limitation in A
- 4 Travel stop / intermediate sheet
- 5 Travel stop for flow rate limitation in B

Straight hand lever

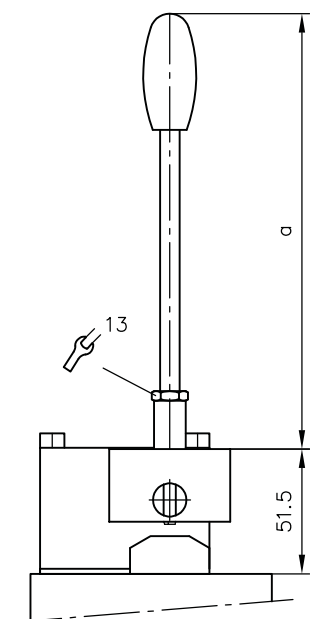

Coding	a
without coding	180
1	--
2	106

Angled hand levers

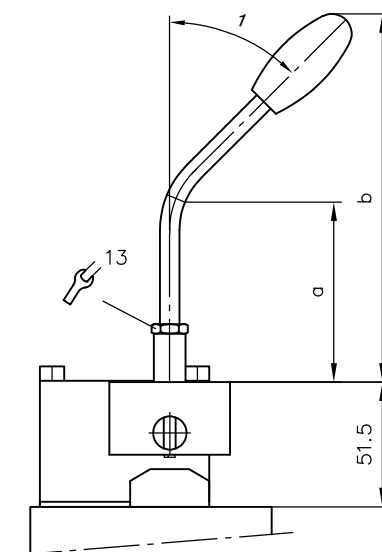

Coding	a	b	1
045	74,5	152	45°
212	26,5	104	12.5°

Actuation AR

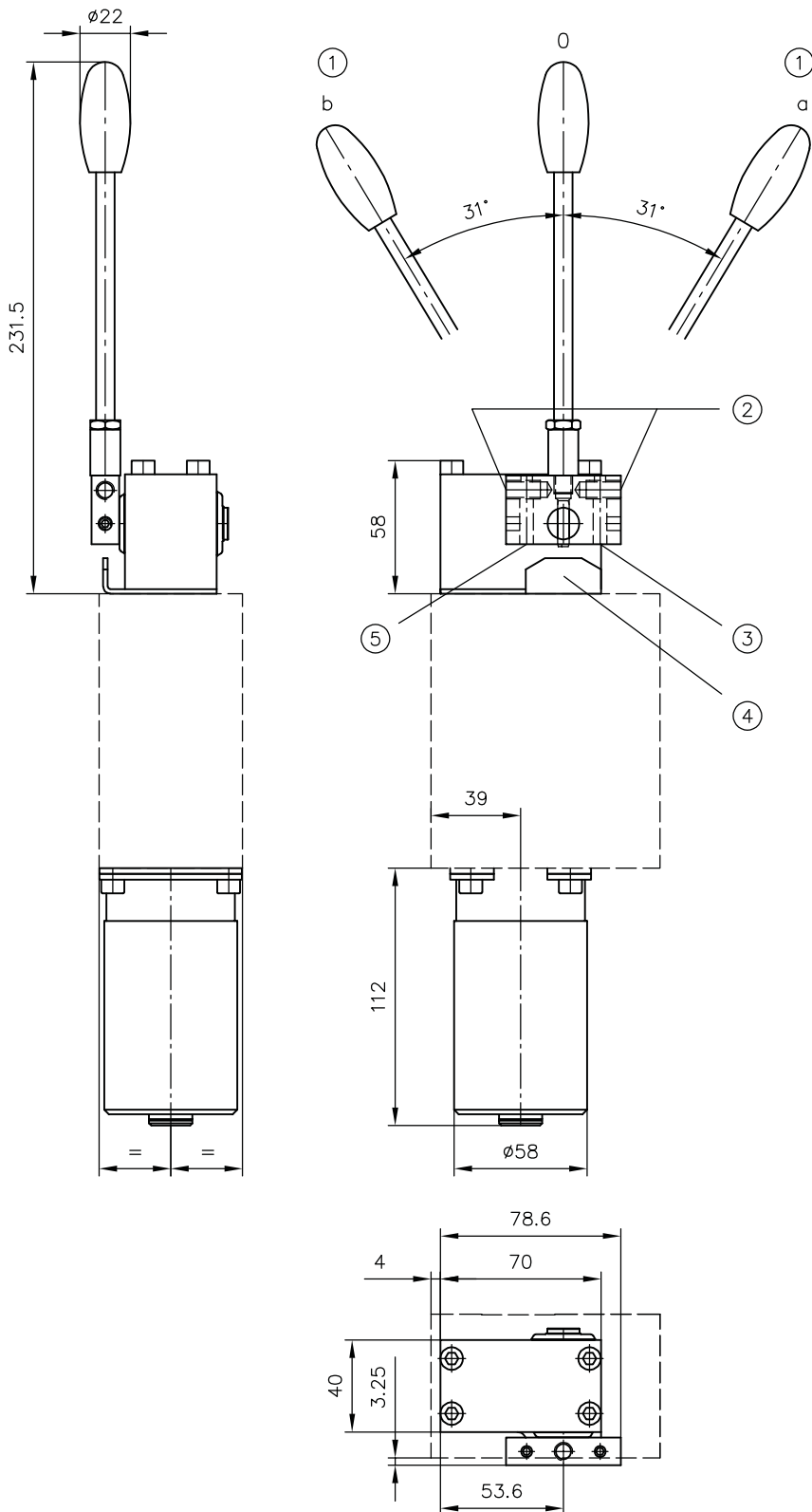

- 1 Switching position 0, a and b
- 2 Hand lever can also be mounted here, thread M8, 15 deep. This lever position cannot be used in combination with ancillary blocks.
- 3 Travel stop for flow rate limitation in A
- 4 Travel stop / intermediate sheet
- 5 Travel stop for flow rate limitation in B

Actuation K

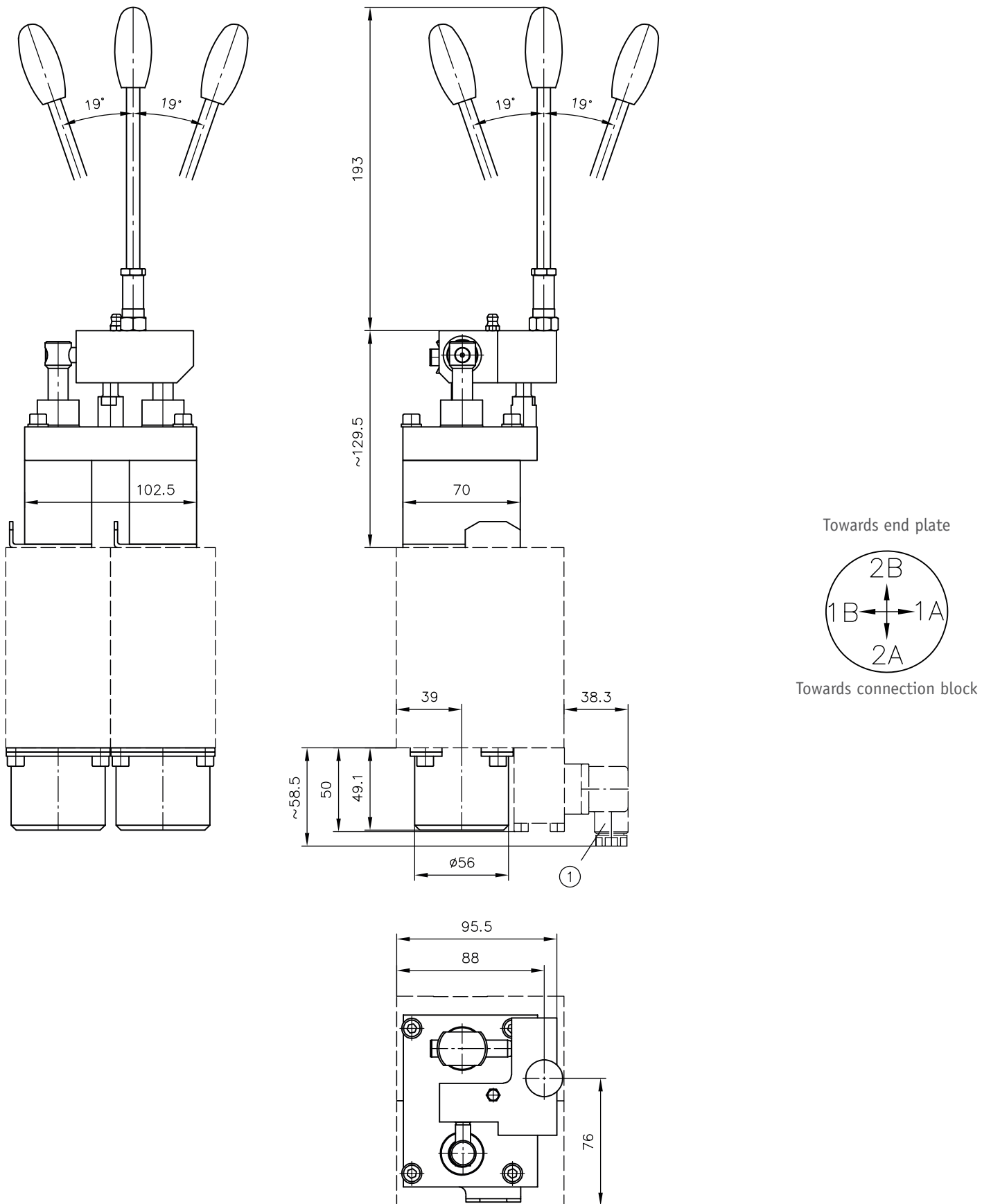

Actuation K12

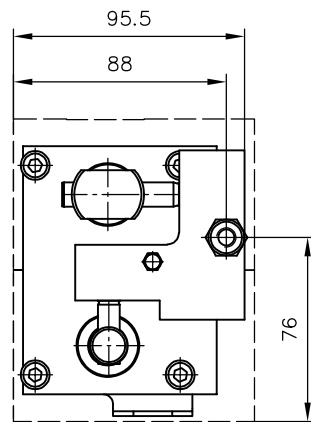
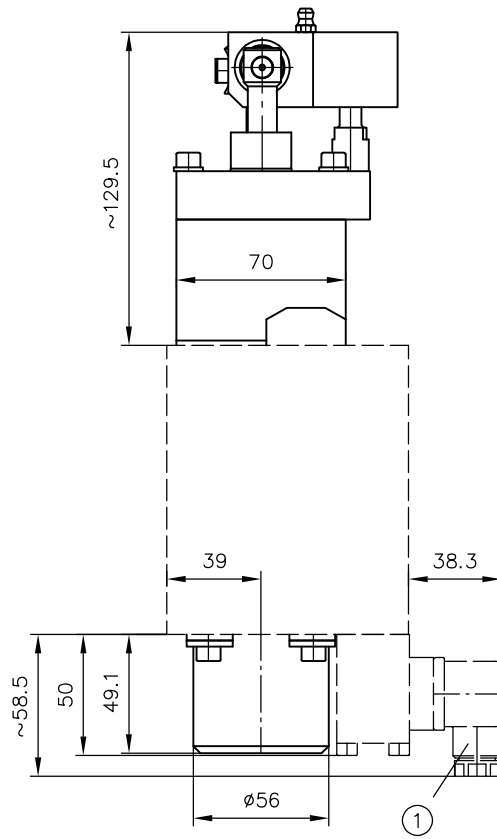
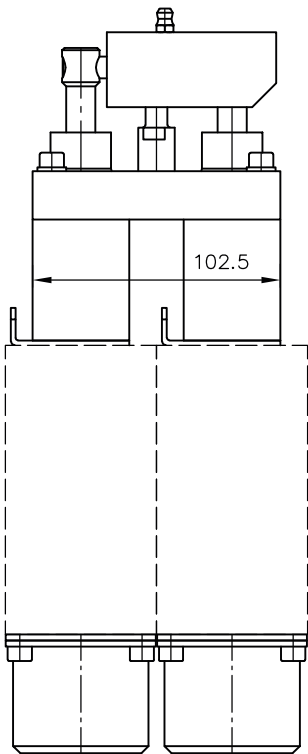

1 Male connector can be mounted offset by 180°

4.2.1.5 With electro-hydraulic actuation

Actuation EA

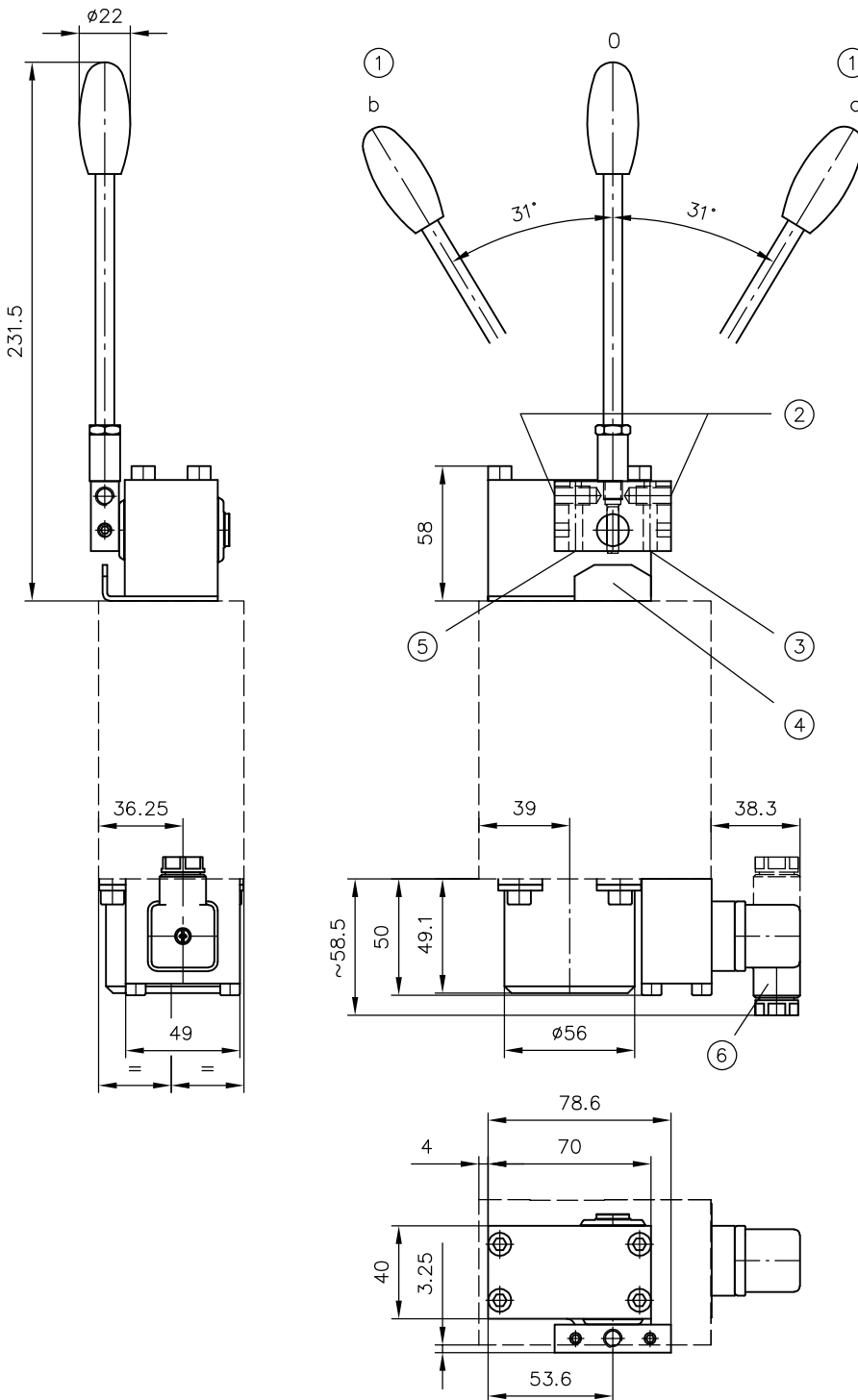

- 1 Switching position 0, a and b
- 2 Hand lever can also be mounted here, thread M8, 15 deep. This lever position cannot be used in combination with ancillary blocks.
- 3 Travel stop for flow rate limitation in A
- 4 Travel stop / intermediate sheet
- 5 Travel stop for flow rate limitation in B
- 6 Male connector can be mounted offset by 180°

Actuation EM

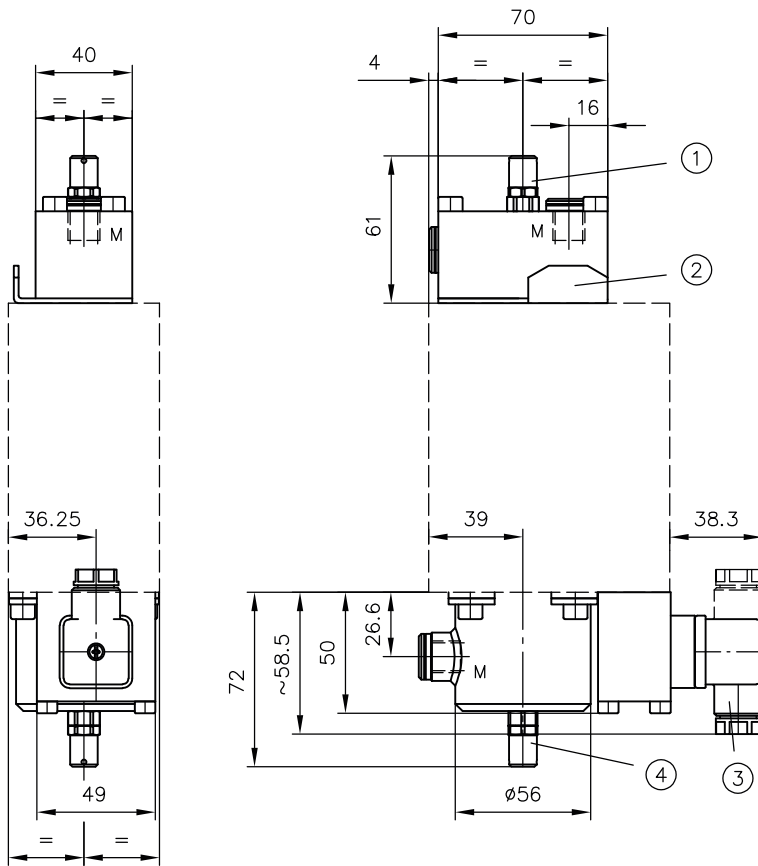

- 1 Travel stop for flow rate limitation in A
- 2 Travel stop / intermediate sheet
- 3 Male connector can be mounted offset by 180°
- 4 Travel stop for flow rate limitation in B

Actuation **EI**

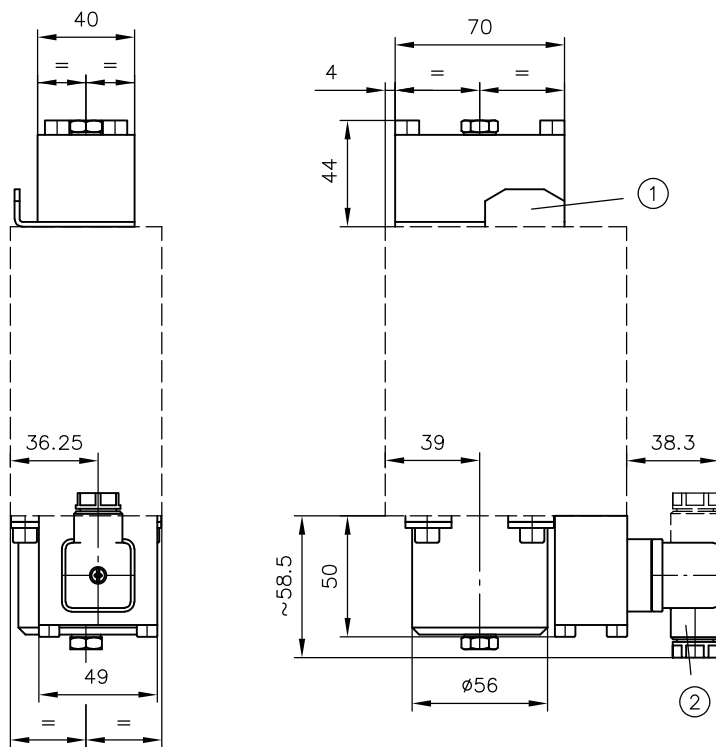

- 1 Travel stop intermediate sheet
- 2 Male connector can be mounted offset by 180°

Actuation **EOA**

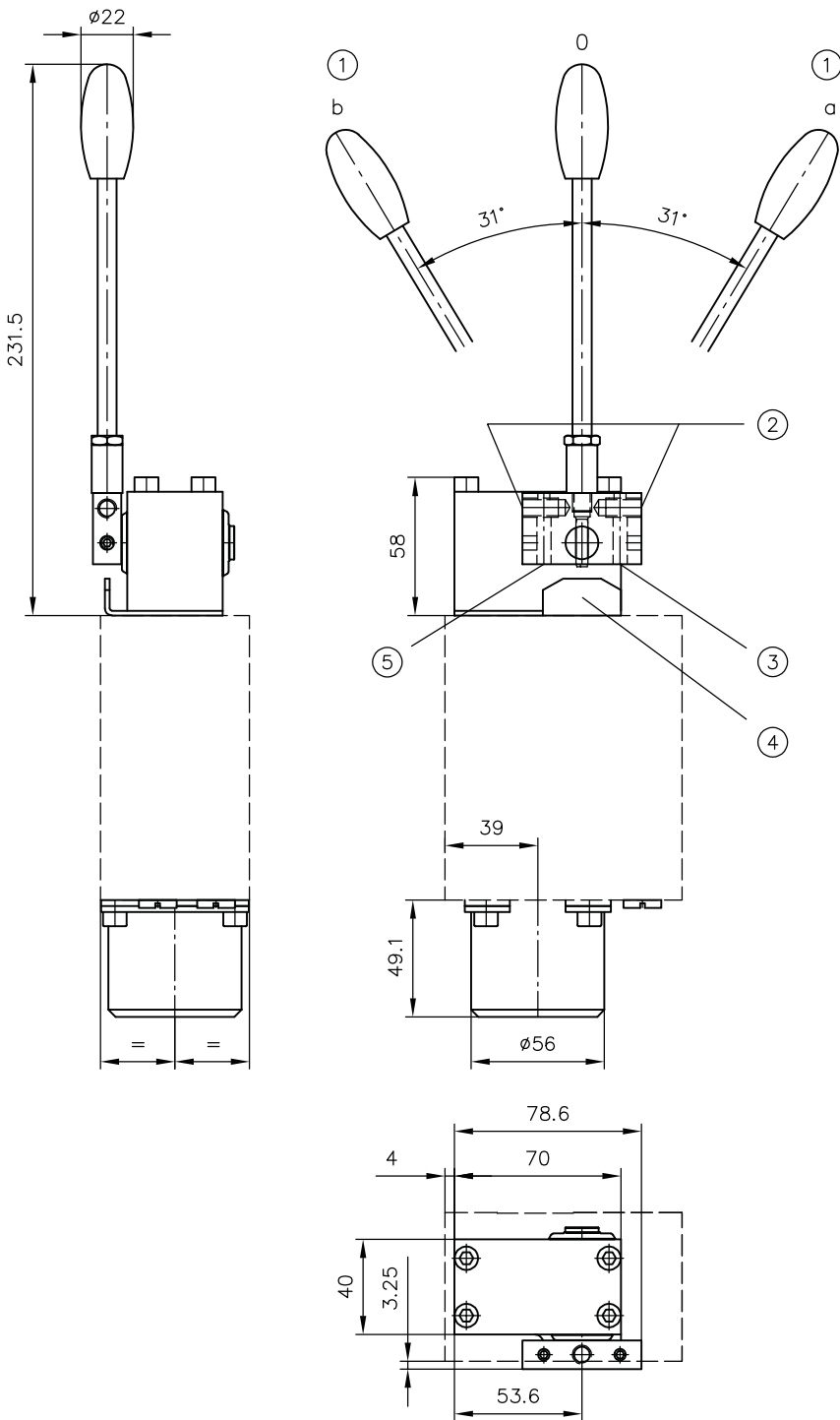

- 1 Switching position 0, a and b
- 2 Hand lever can also be mounted here, thread M8, 15 deep. This lever position cannot be used in combination with ancillary blocks.
- 3 Travel stop for flow rate limitation in A
- 4 Travel stop / intermediate sheet
- 5 Travel stop for flow rate limitation in B

Solenoid version drawings

S 12 (T), S 24 (T)

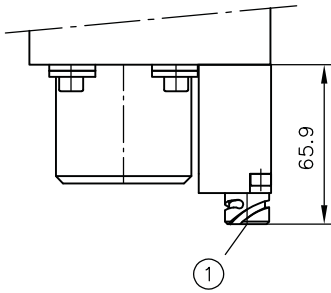

1 Bayonet plug connection PA 6

AMP 12 K 4, AMP 24 K 4

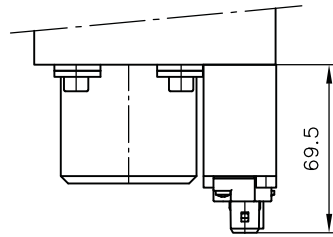

AMP 24 H 4 T

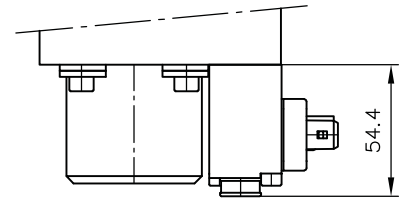

**G 12 T, G 24 T
X 12 T, X 24 T**

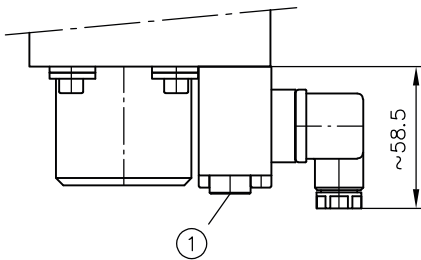

1 Manual override

DT 12, DT 24

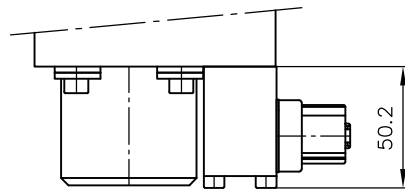

DT 12 K, DT 24 K

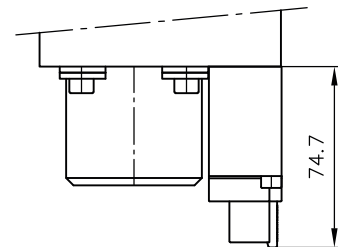

G 24 C 4, X 24 C 4

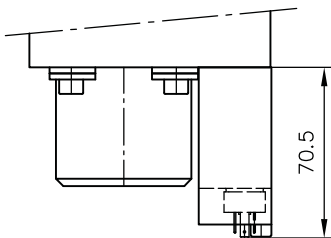

G 12 IS, G 24 MSHA, G 24 M2FP

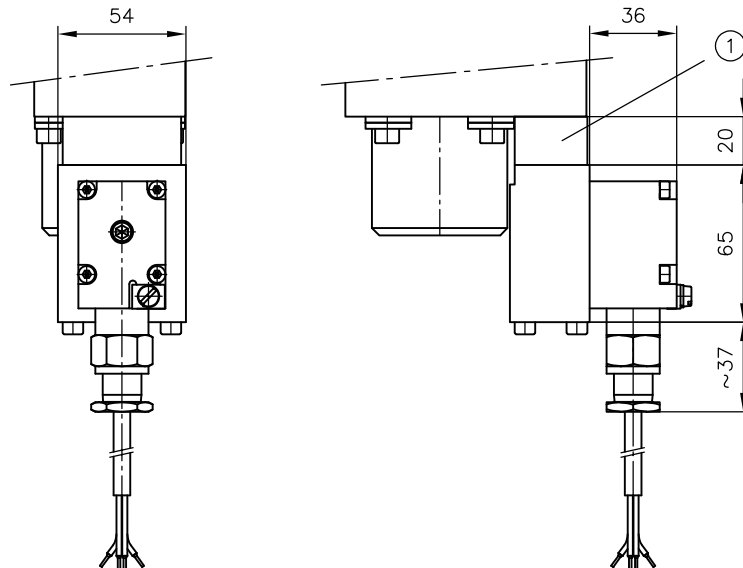

1 Intermediate plate only in combination with actuations ER and EAR

G 24 EX, G 24 EX 4

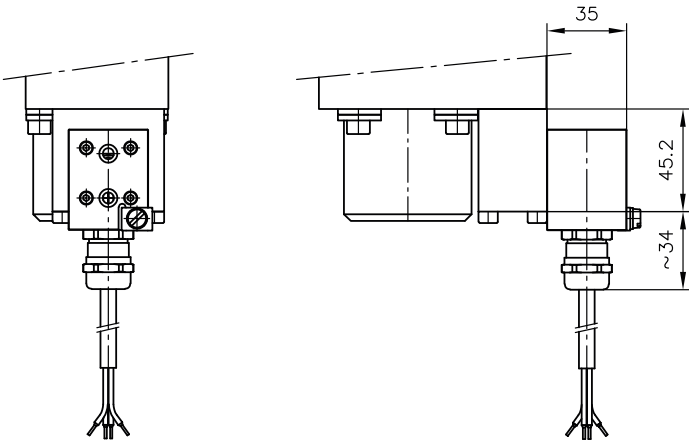

X 24 TEX 4 70 FM

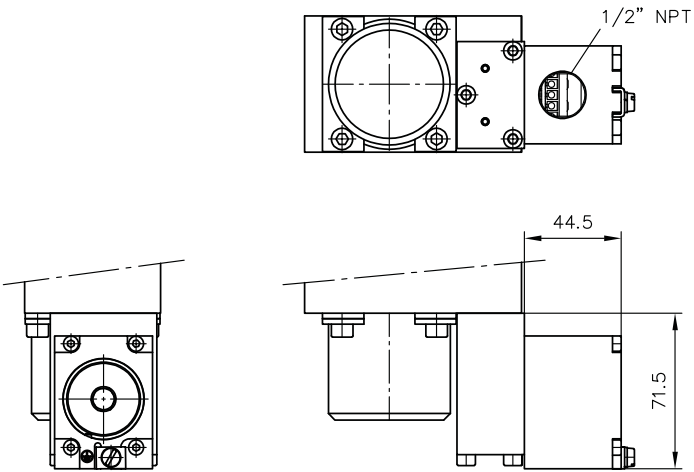

4.2.1.6 With CAN actuation

Actuation **EACAN**

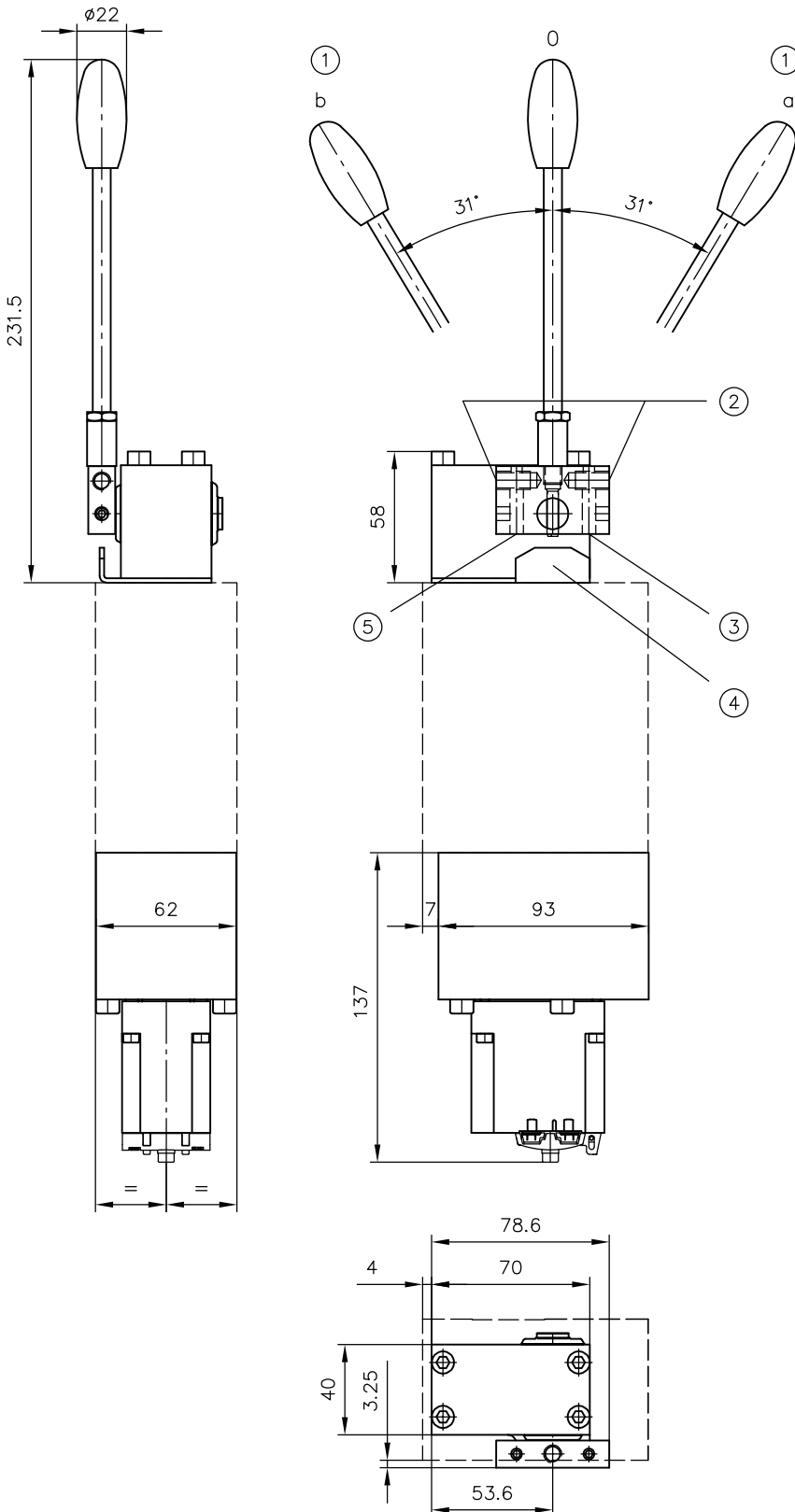

- 1 Switching position 0, a and b
- 2 Hand lever can also be mounted here, thread M8, 15 deep. This lever position cannot be used in combination with ancillary blocks.
- 3 Travel stop for flow rate limitation in A
- 4 Travel stop / intermediate sheet
- 5 Travel stop for flow rate limitation in B

4.2.1.7 With hydraulic actuation

Actuation EHA (UNF)

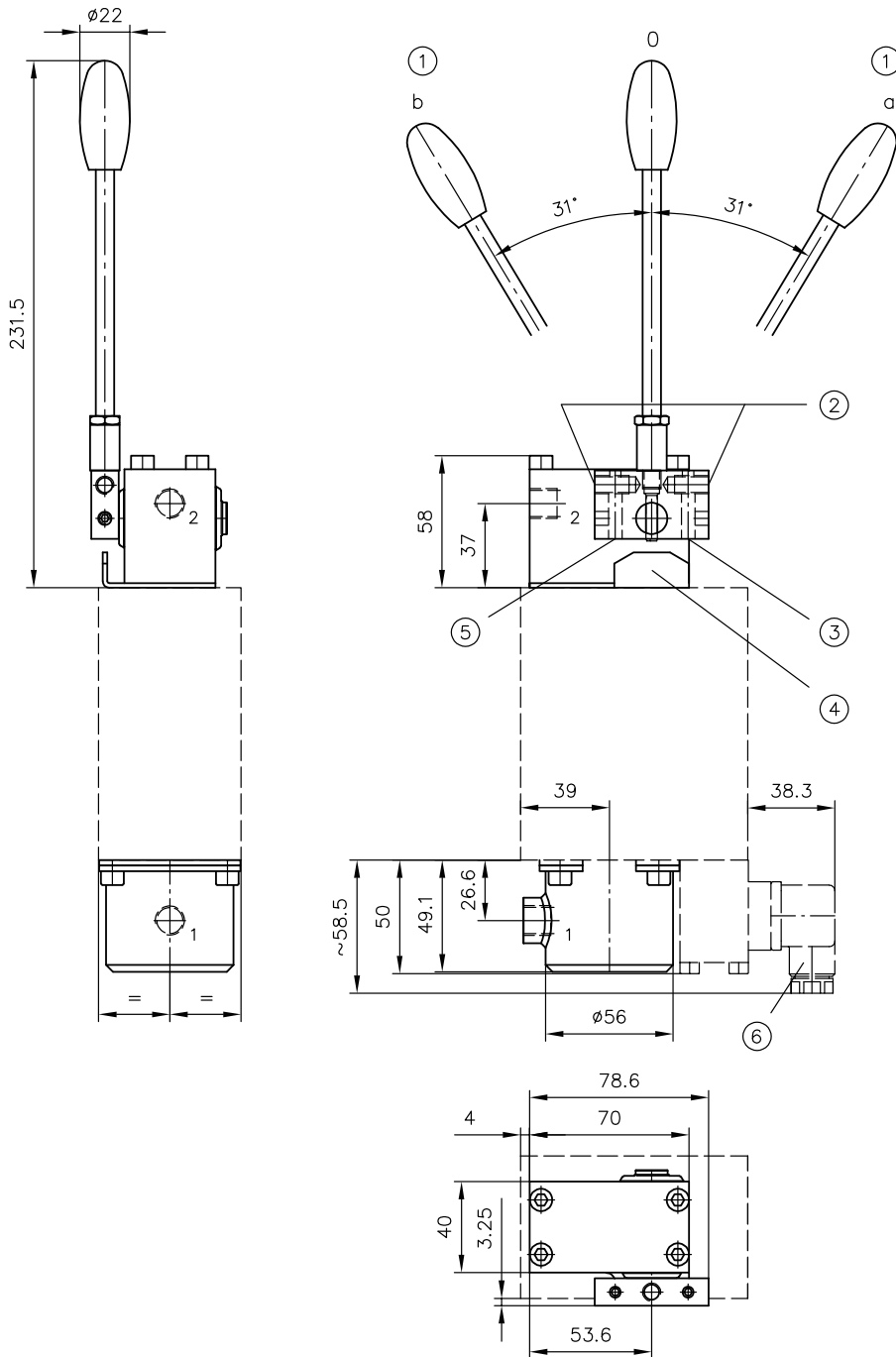

- 1 Switching position 0, a and b
- 2 Hand lever can also be mounted here, thread M8, 15 deep. This lever position cannot be used in combination with ancillary blocks.
- 3 Travel stop for flow limitation at A
- 4 Travel stop intermediate sheet
- 5 Travel stop for flow limitation at B
- 6 Male connector can be mounted offset by 180°

**Ports
(ISO 228-1 or SAE J 514)**

1, 2	G 1/4 7/16-20 UNF-2B (SAE-4)
------	---------------------------------

Actuation H (UNF)

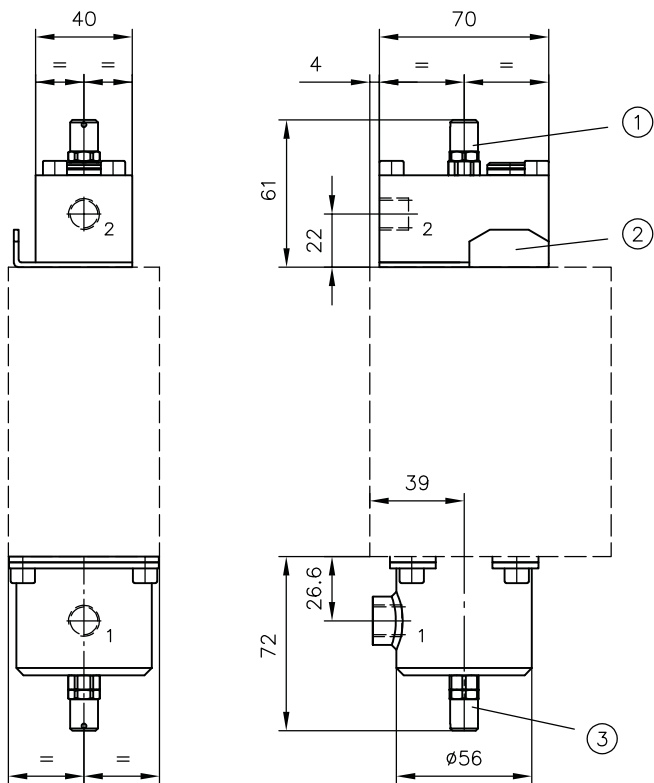

Actuation F (UNF)

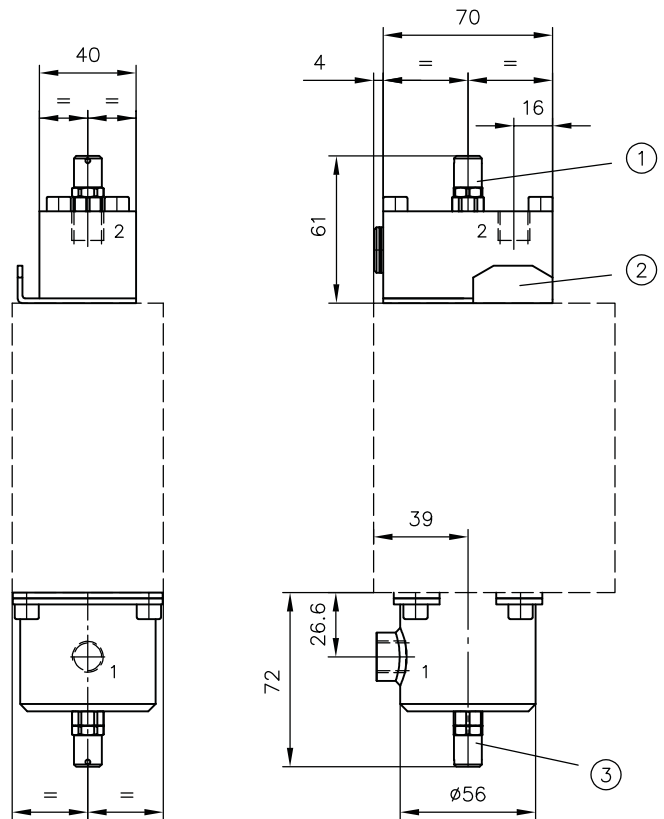

Actuation EOZM (UNF)

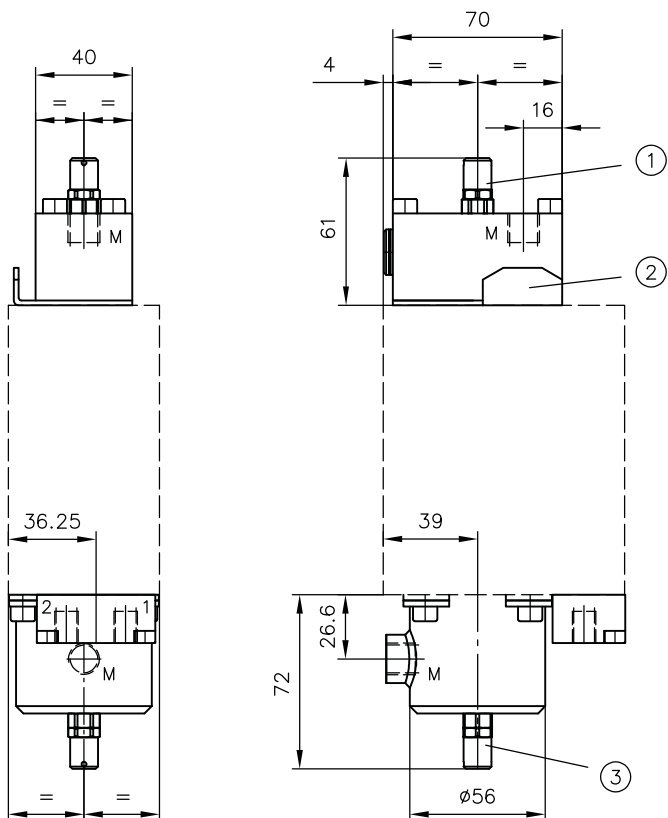

- 1 Travel stop for flow limitation at A
- 2 Travel stop intermediate sheet
- 3 Travel stop for flow limitation at B

Ports
(ISO 228-1 or SAE J 514)

1, 2, M	G 1/4 7/16-20 UNF-2B (SAE-4)
---------	---------------------------------

4.2.1.8 With pneumatic actuation

Actuation PA

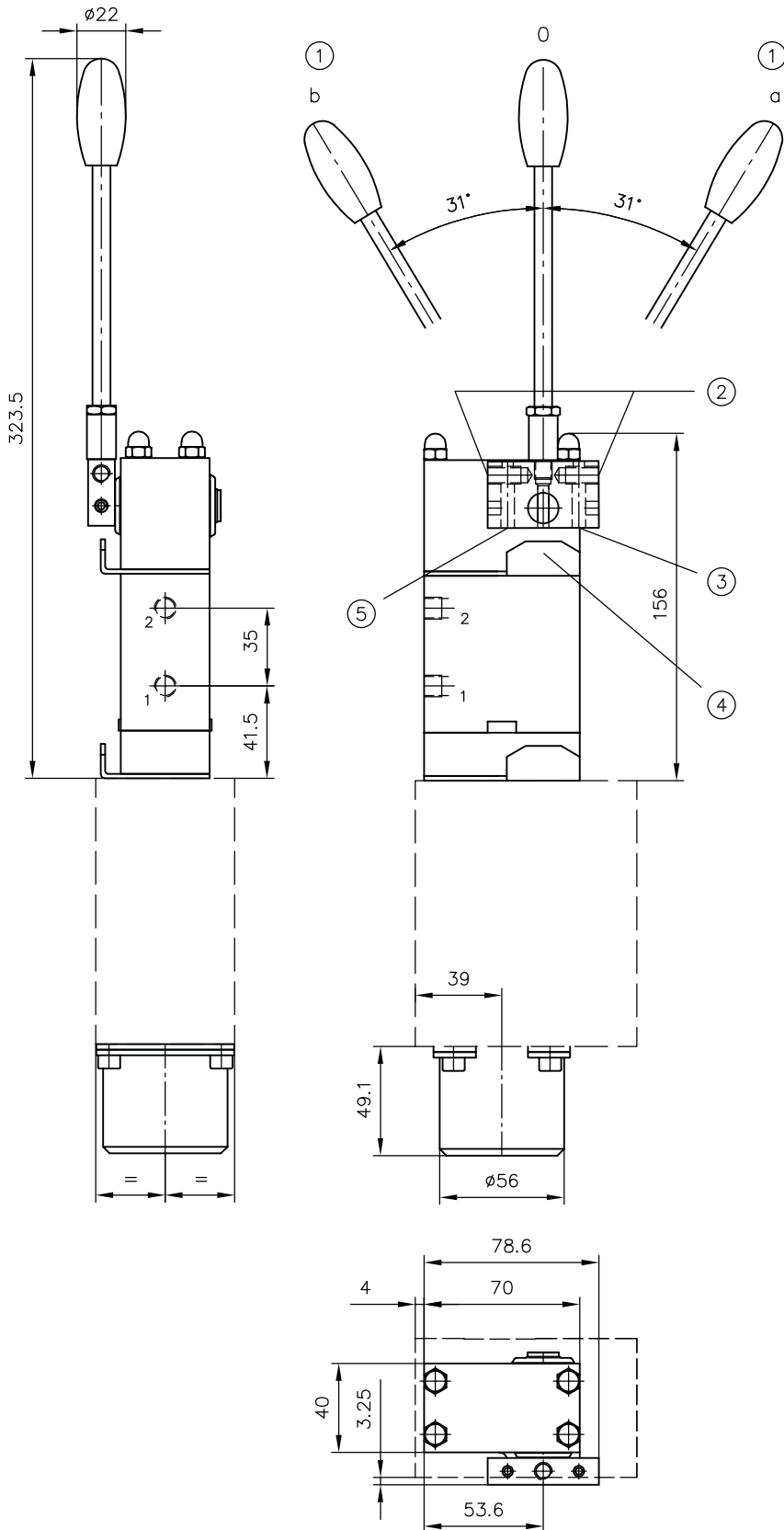

- 1 Switching position 0, a and b
- 2 Hand lever can also be mounted here, thread M8, 15 deep. This lever position cannot be used in combination with ancillary blocks.
- 3 Travel stop for flow rate limitation in A
- 4 Travel stop / intermediate sheet
- 5 Travel stop for flow rate limitation in B

Ports (ISO 228-1)

1, 2 G 1/8

4.2.1.9 Switching position monitoring, displacement transducer

Coding **U, WA**

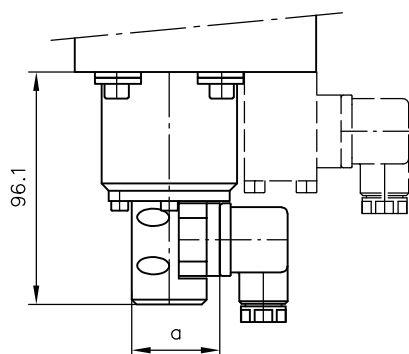

Coding **WA-EX, WA-IS**

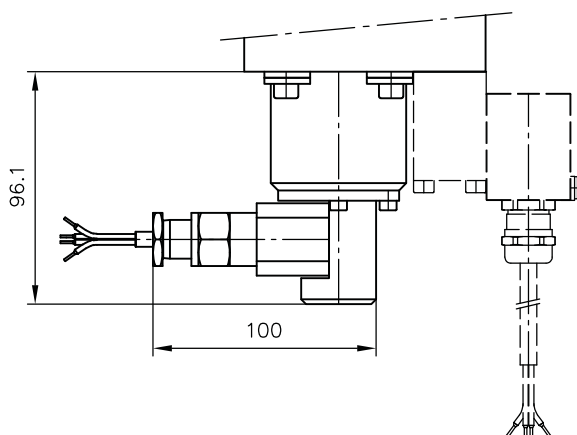

Coding	a
U	49,5
WA	36,4

4.2.1.10 LS pressure limitation

Coding AB, A., B., A.. B..

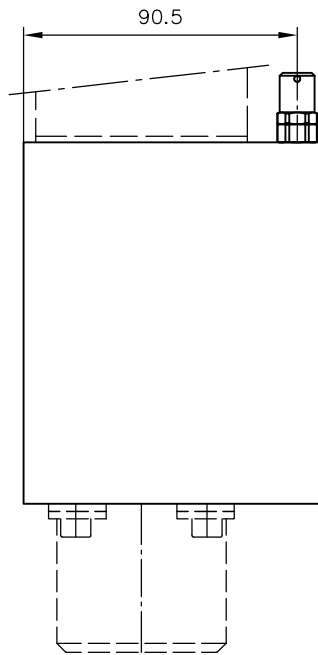
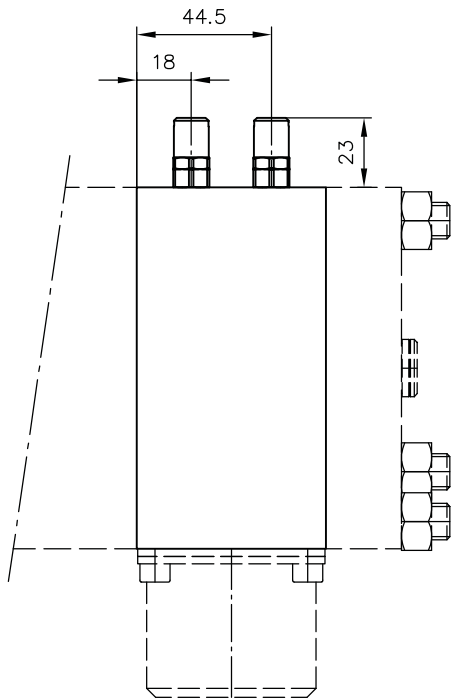

Coding C..

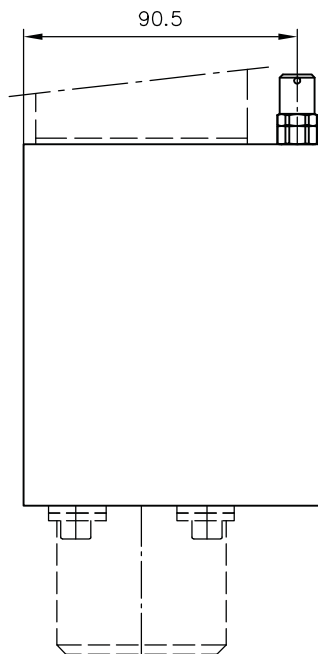
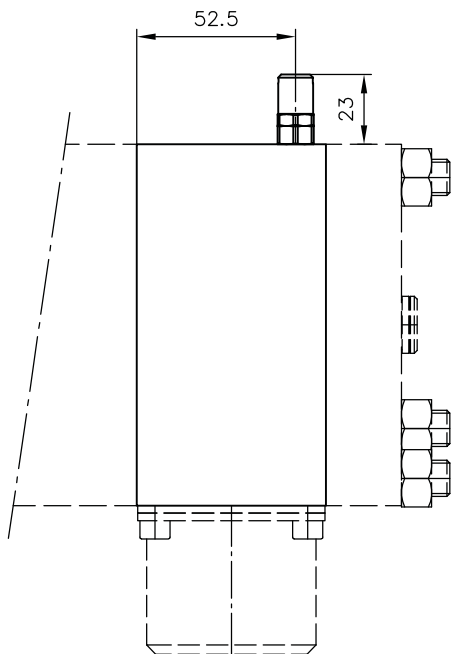

4.2.1.11 Electric LS relief or LS pressure limitation

Coding **F1, F2, F3, FP**

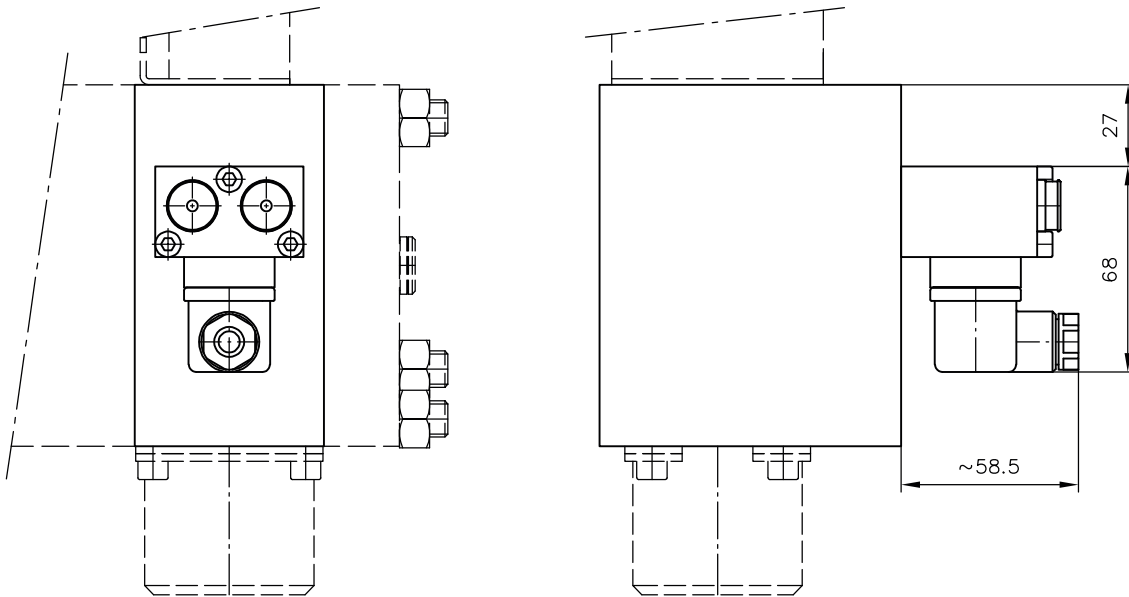

Coding **FPH 1, FPH 2, FPH 3**

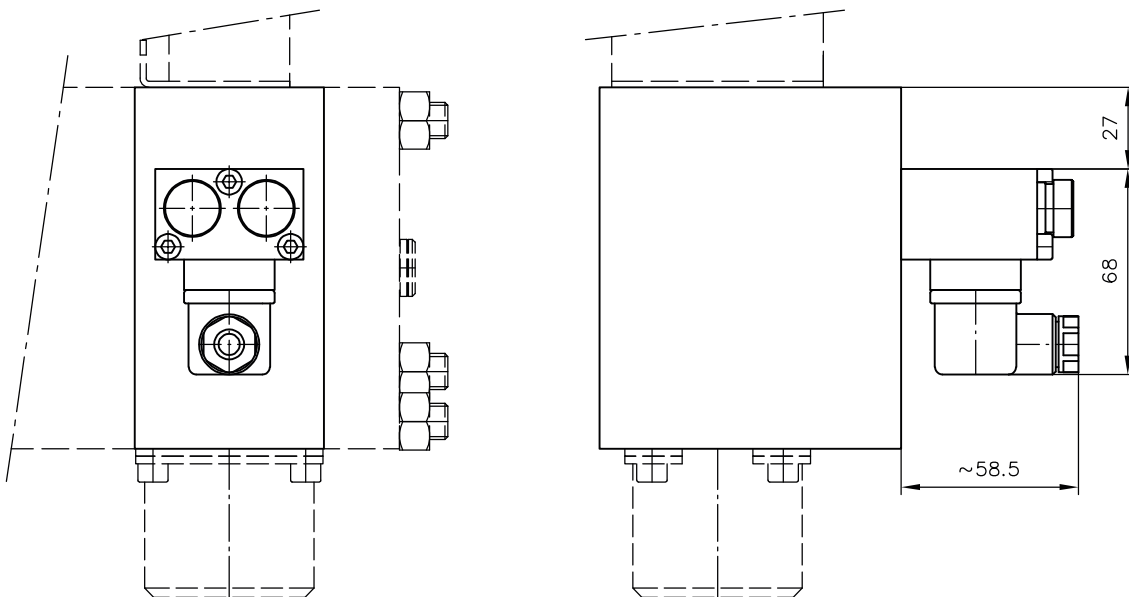

Coding **FPC-S..**

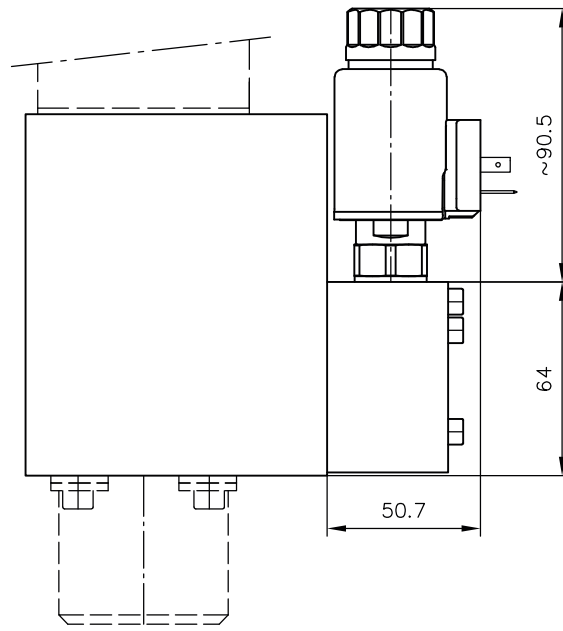
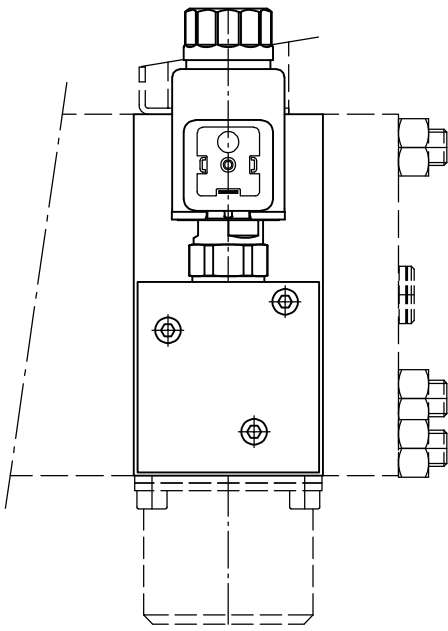

Coding **FPC-R..**

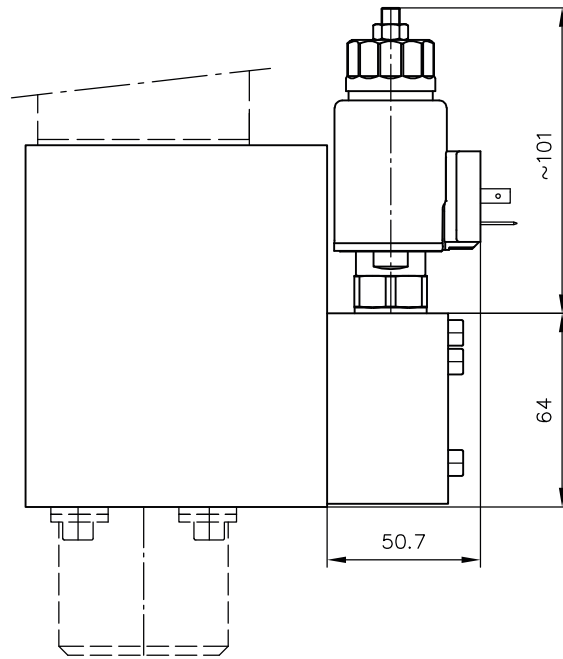
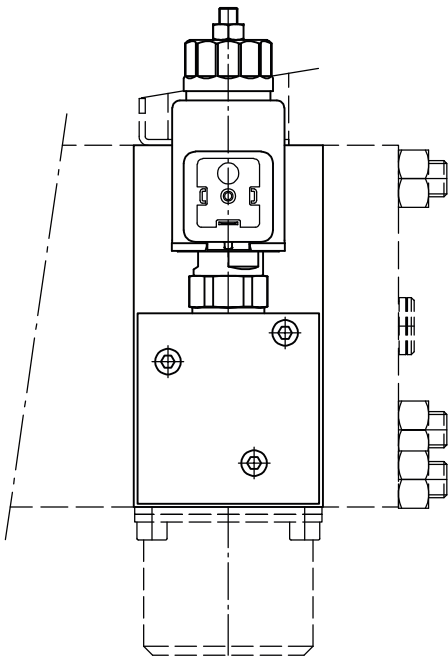

Coding **FPCX**

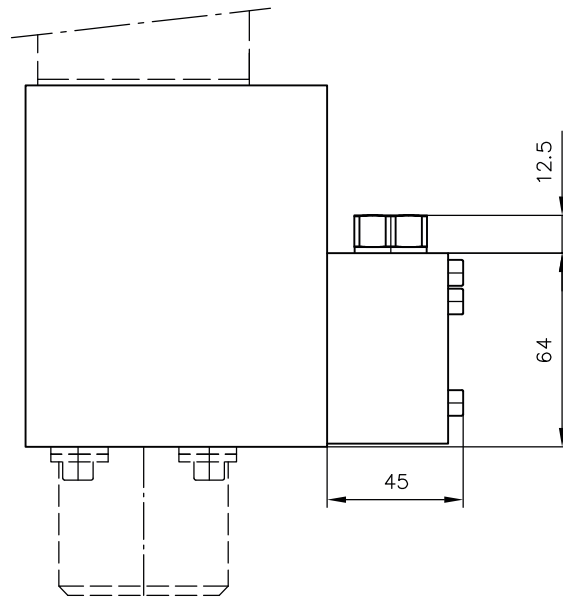
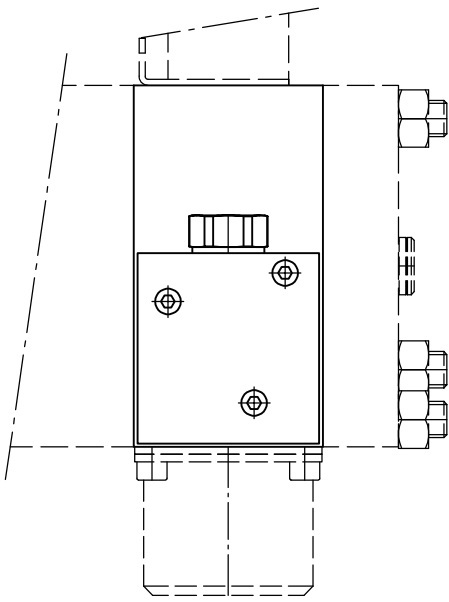

4.2.1.12 LS port for external limitation

Coding **S**

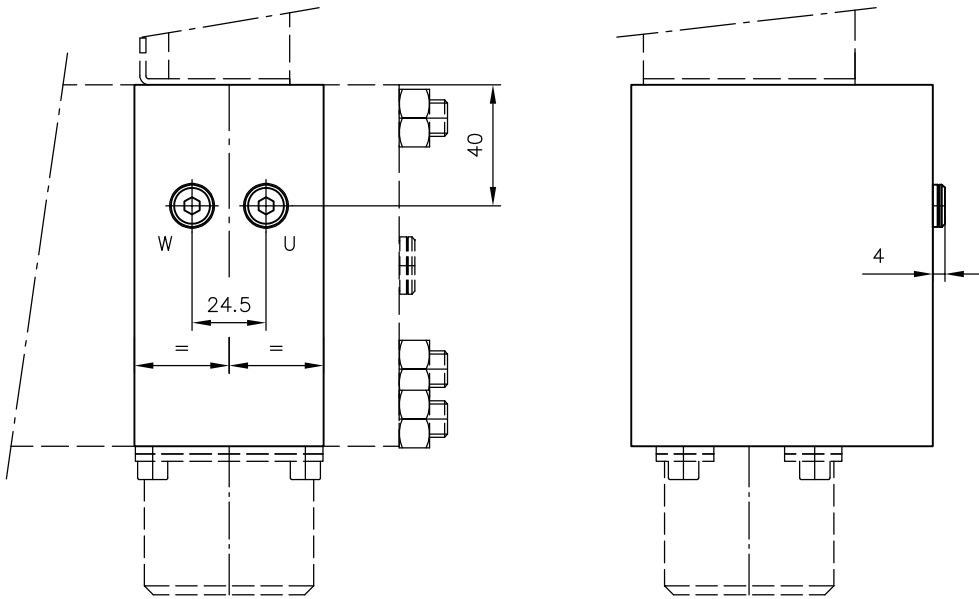

Coding **S1**

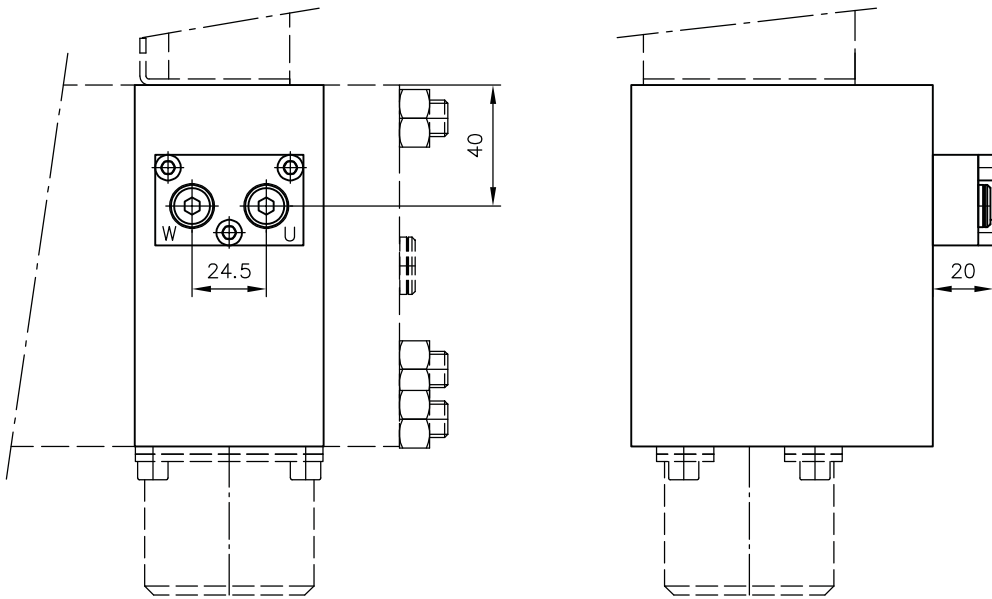

Coding

Ports (ISO 228-1)

U, W

S, S1

G 1/8

Coding **X**

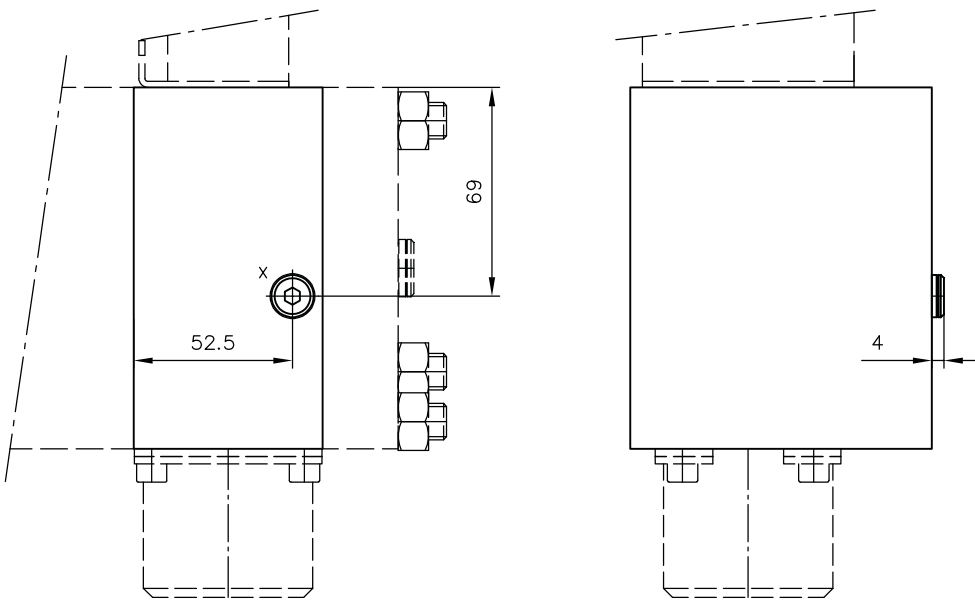

Coding **XXH**

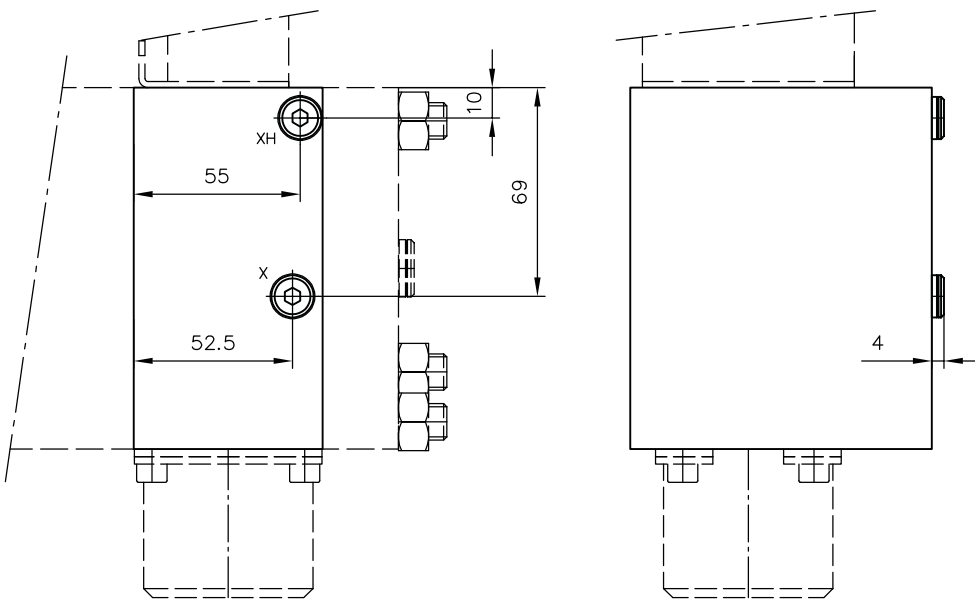

Coding

Ports (ISO 228-1)

X, XH

X, XXH

G 1/8

4.2.2 Ancillary block

see Chapter 2.2.2, "Ancillary block"

/5, /UNF 5

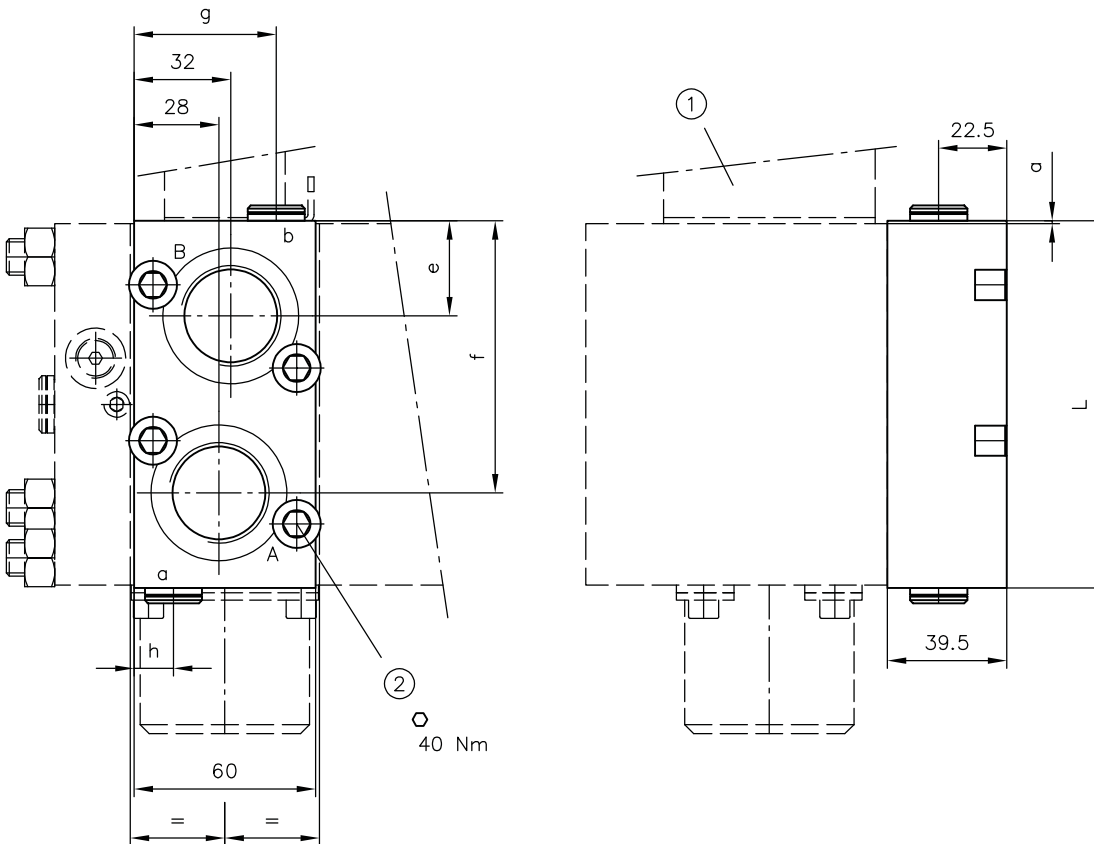

- 1 Directional valve section
- 2 Cylinder screws ISO 4762-M10x40-A2-70

Coding	L	a	e	f	g	h	Ports (ISO 228-1 or SAE J 514)	
							A, B	a, b
/5	121,5	1	31,5	90	47	13	G 1	G 1/4
/UNF 5	119,5	--	30,5	89	19,5	40,5	1 5/16-12 UN-2B (SAE-16)	7/16-20 UNF-2B (SAE-4)

/JIS 5

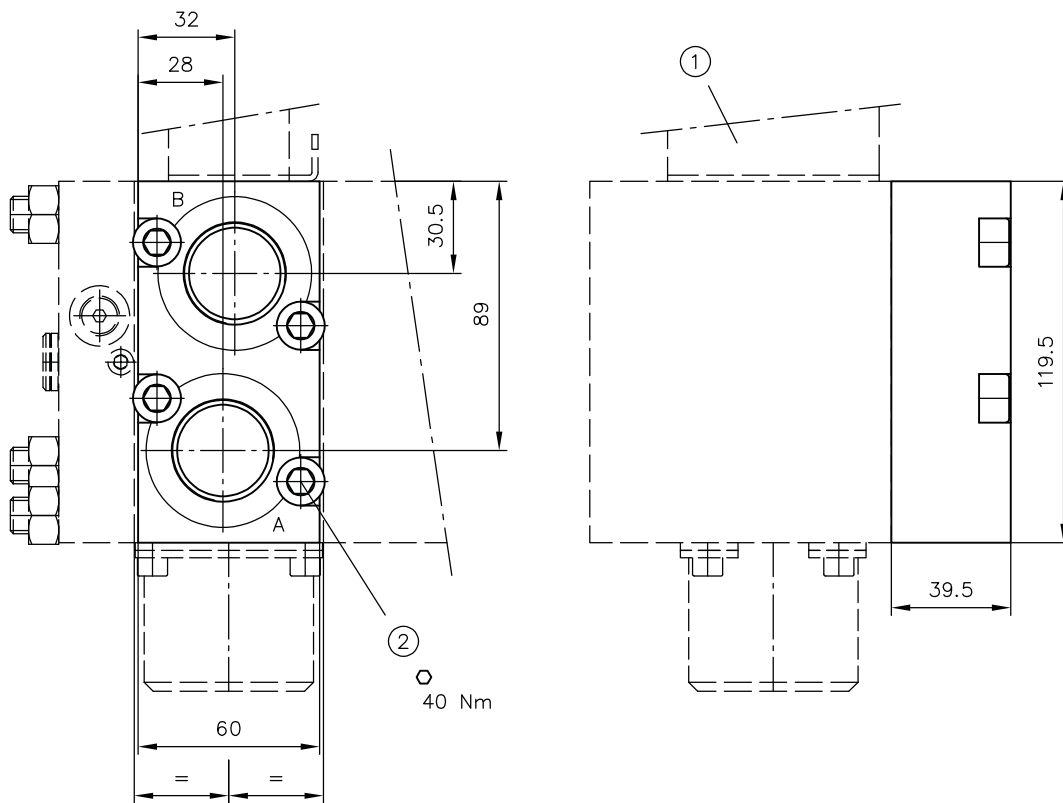

- 1 Directional valve section
- 2 Cylinder screws ISO 4762-M10x40-A2-70

Ports (ISO 228-1)

A, B	G 1
------	-----

/5 AS... BS..., /5 AN... BN...
/UNF 5 AS... BS..., /UNF 5 AN... BN...

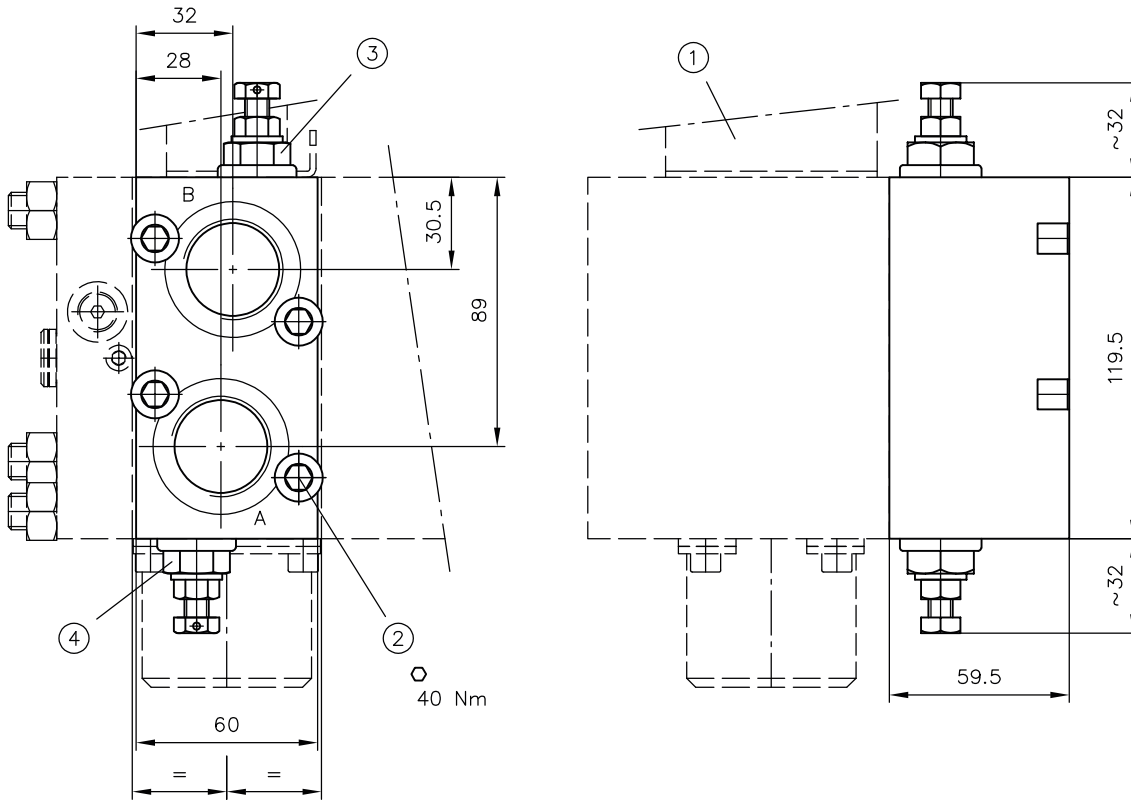

- 1 Directional valve section
- 2 Cylinder screws ISO 4762-M10x60-A2-70
- 3 Pressure setting 1
- 4 Pressure setting 2

Coding	Ports (ISO 228-1 or SAE J 514)
	A, B
/5 AS... BS... /5 AN... BN...	G 1
/UNF 5 AS... BS... /UNF 5 AN... BN...	1 5/16-12 UN-2B (SAE-16)

/5 VV, /5 SS, /5 XV
/5 SX, /5 XV, /5 XS

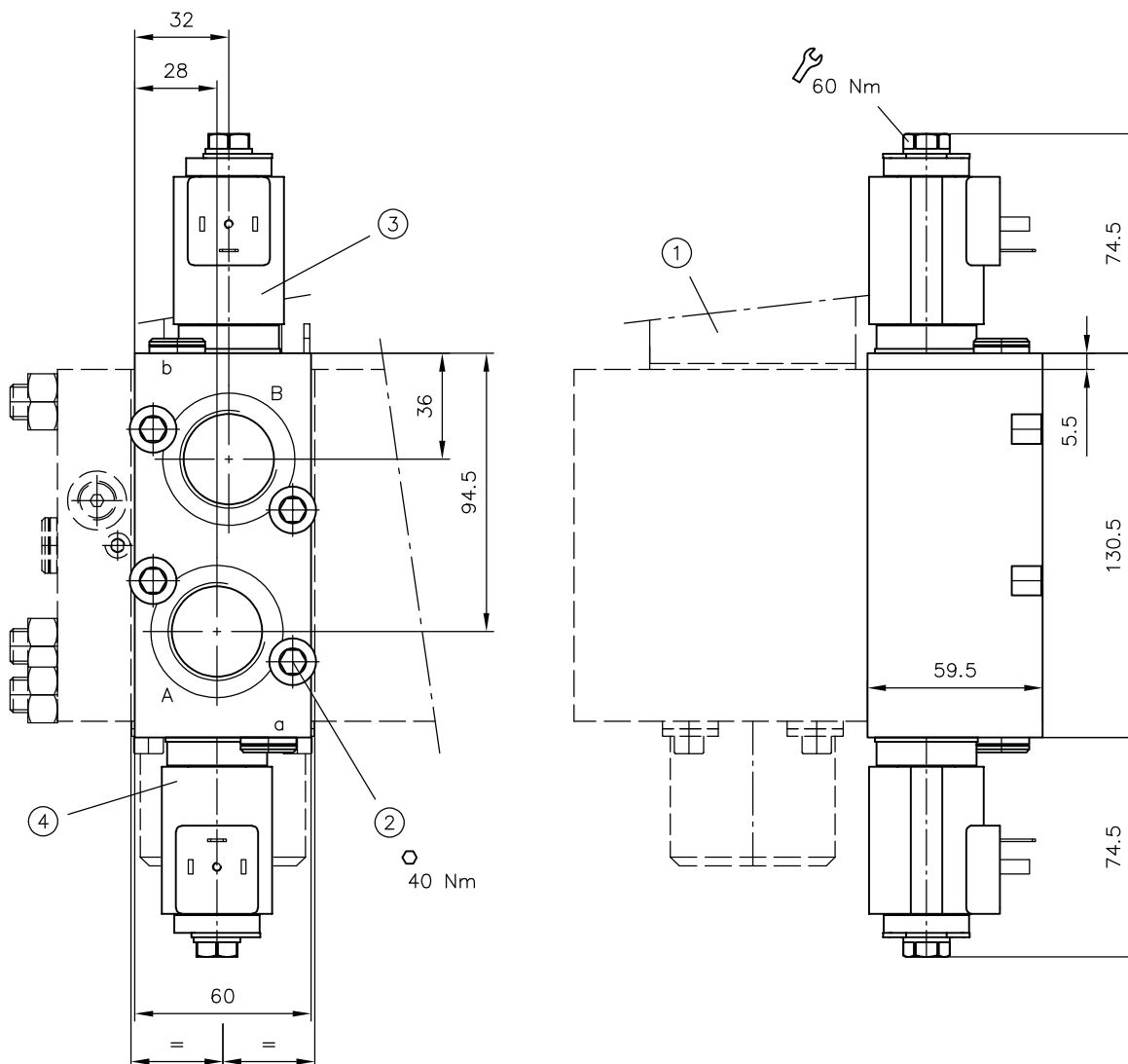

- 1 Directional valve section
- 2 Cylinder screws ISO 4762-M10x60-A2-70
- 3 Check valve type EM 42 V(S) omitted on type /5 X(S)V
- 4 Check valve type EM 42 V(S) omitted on type /5 XV(S)

Coding	Ports (ISO 228-1)	
	A, B	a, b
/5 VV, /5 SS /5 XV, /5 SX /5 XV, /5 XS	G 1	G 1/4

/4 ASN... BSN...

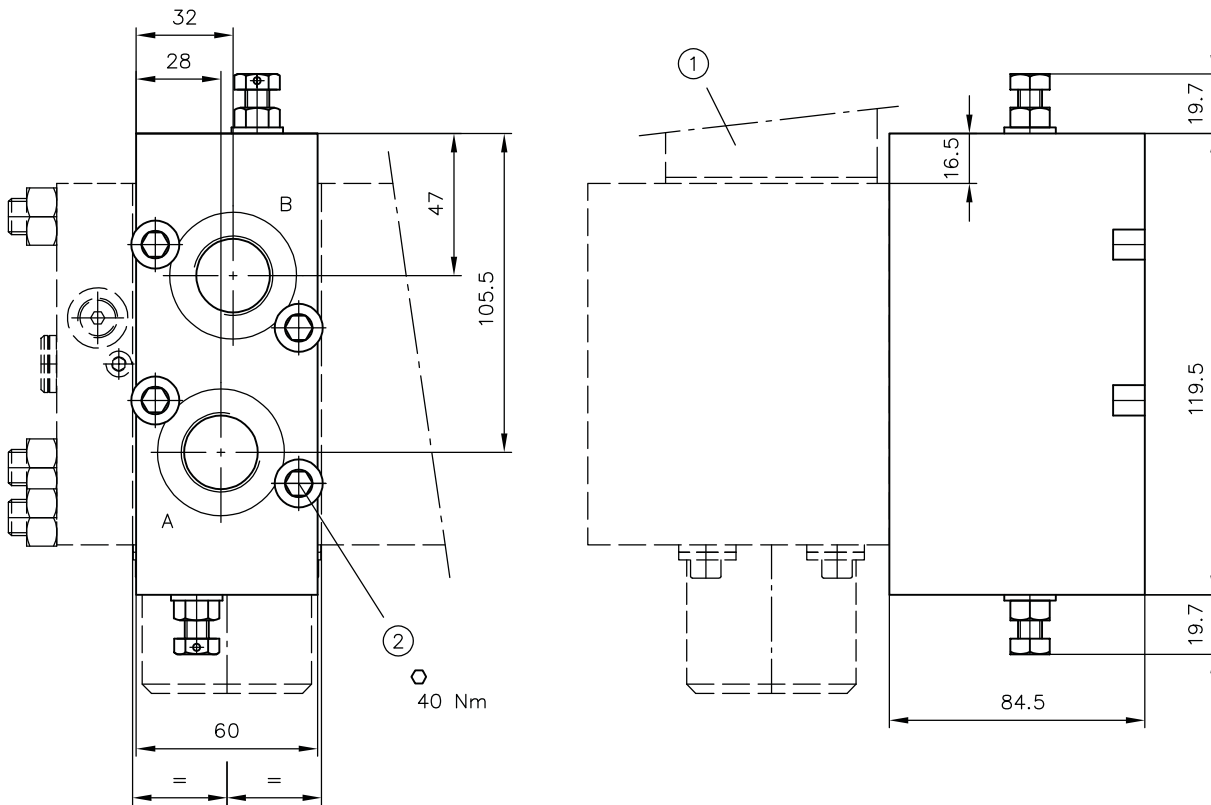

- 1 Directional valve section
- 2 Cylinder screws ISO 4762-M10x85-A2-70

Coding

Ports (ISO 228-1)

A, B

/4 ASN... BSN...

G 3/4

/5 AN...

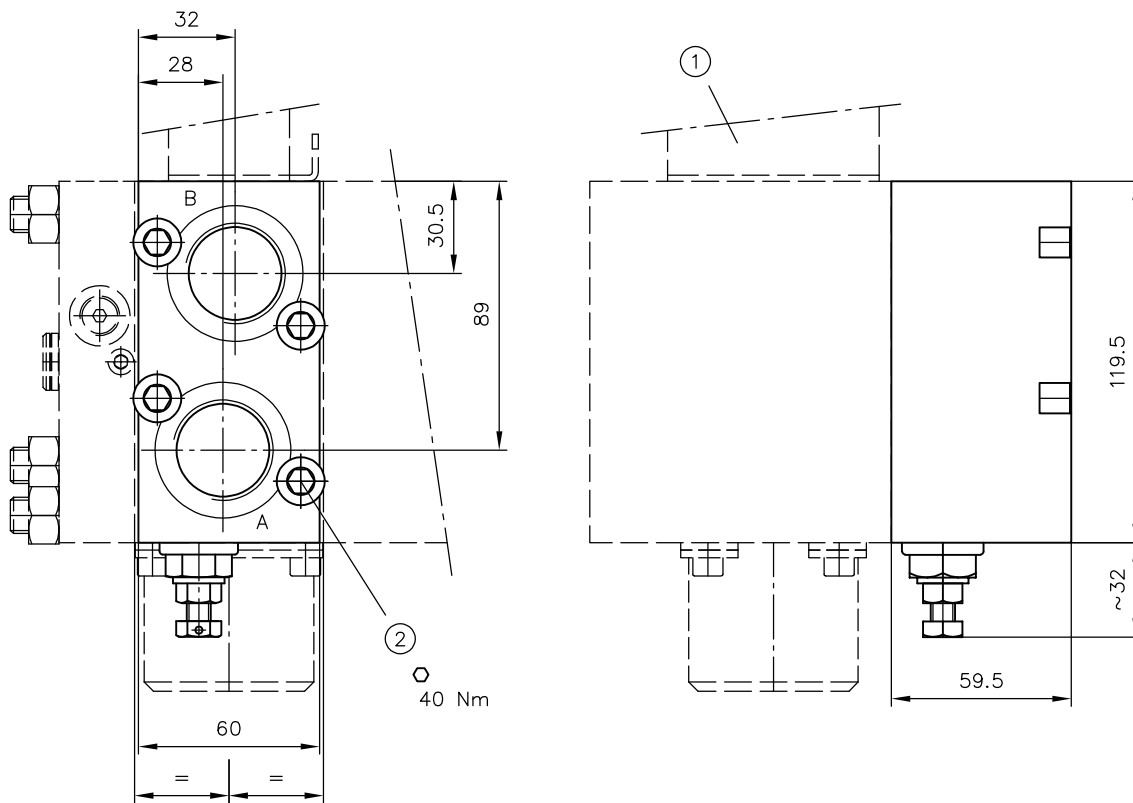

- 1 Directional valve section
- 2 Cylinder screws ISO 4762-M10x85-A2-70

Coding	Ports (ISO 228-1)
	A, B
/5 AN...	G 1

/5 BN...

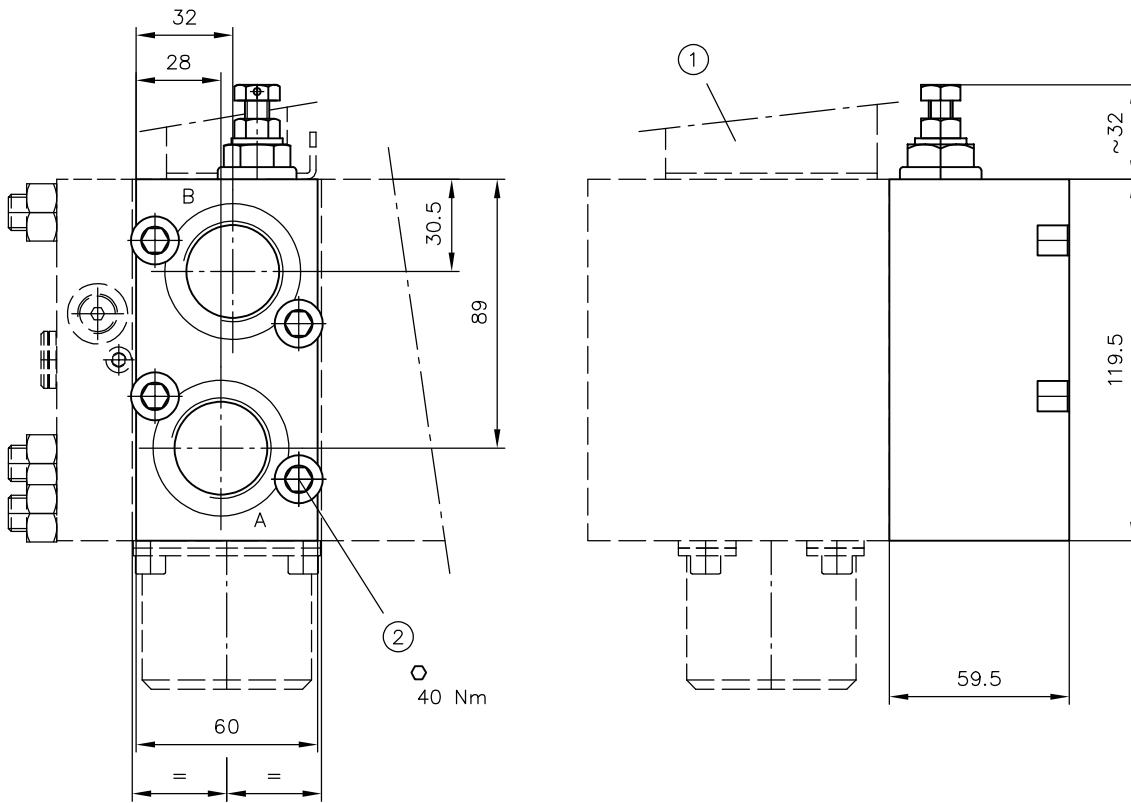

- 1 Directional valve section
- 2 Cylinder screws ISO 4762-M10x85-A2-70

Coding	Ports (ISO 228-1)
/5 BN...	A, B
	G 1

/5 AL...

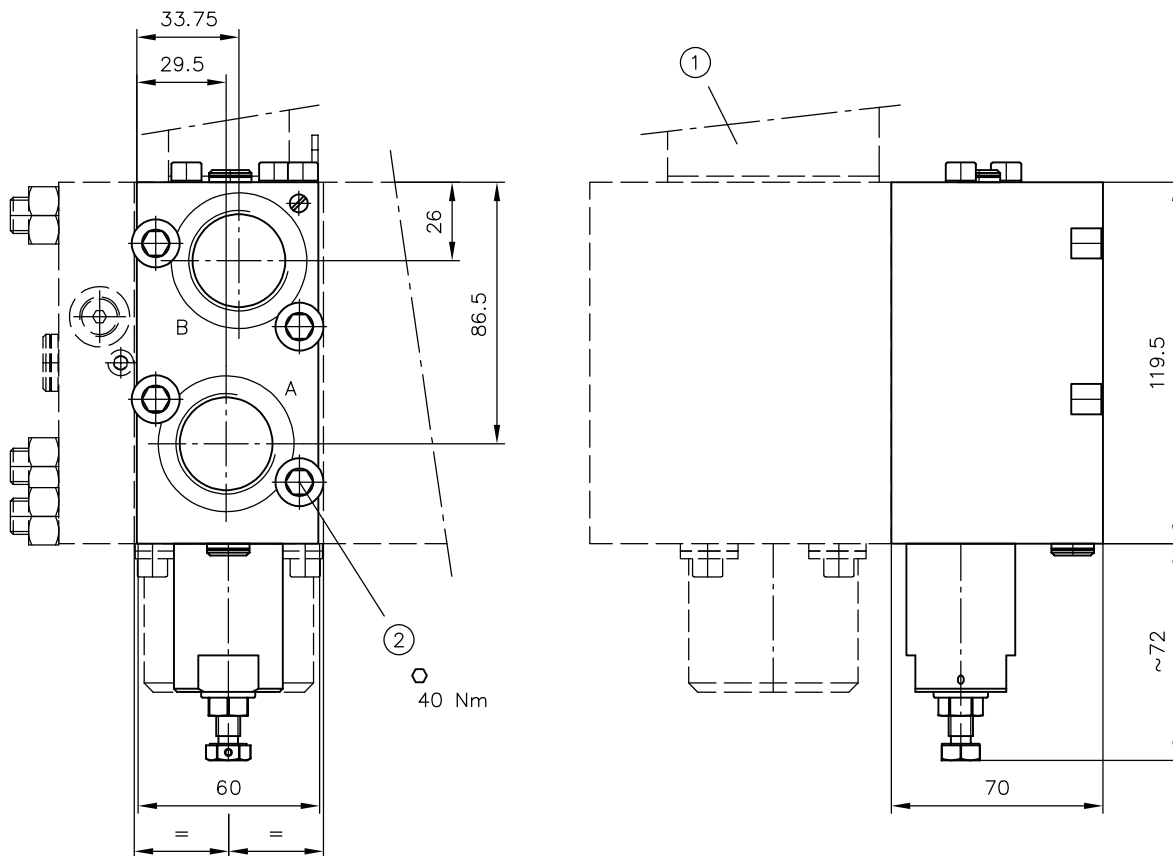

- 1 Directional valve section
- 2 Cylinder screws ISO 4762-M10x85-A2-70

Coding	Ports (ISO 228-1)
/5 AL...	A, B G 1

/5 BL...

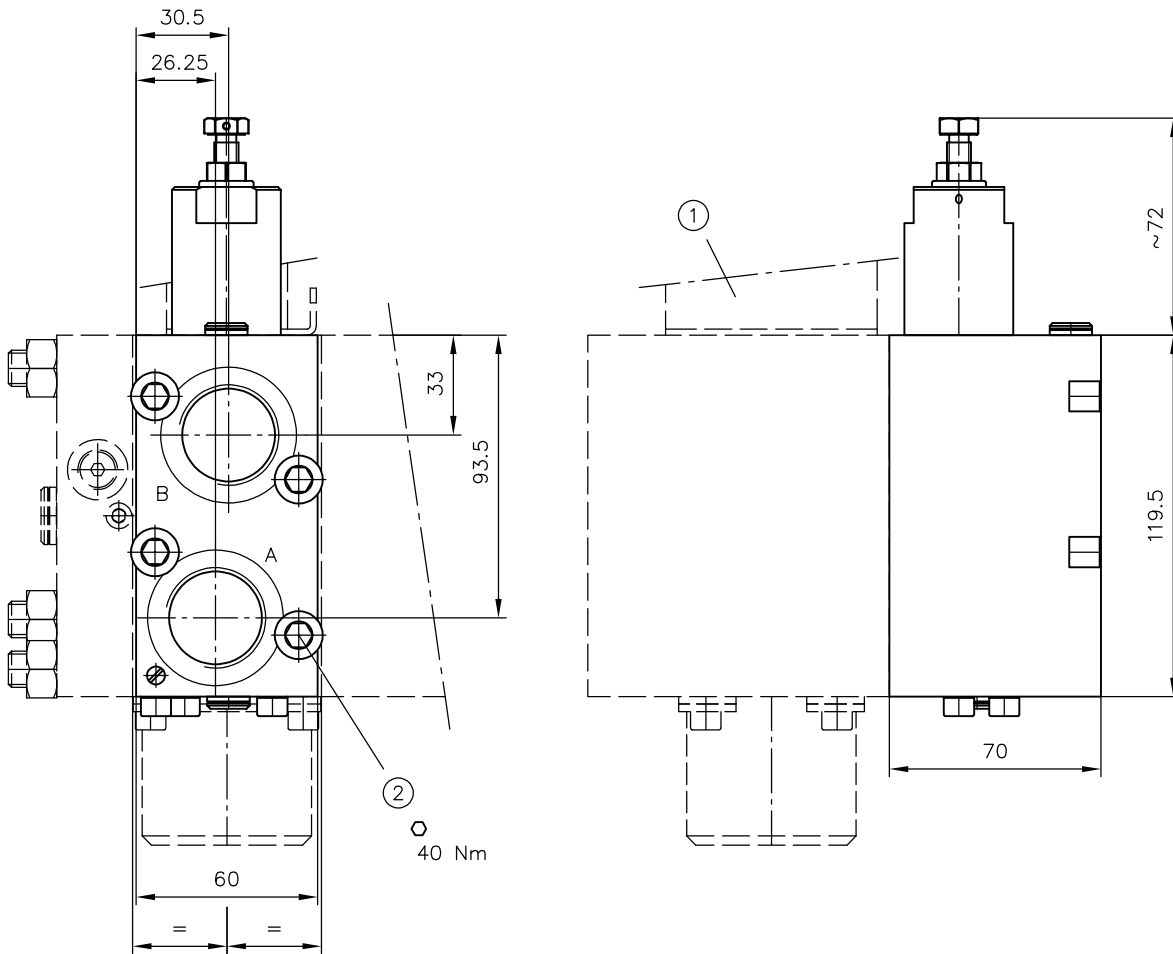

- 1 Directional valve section
- 2 Cylinder screws ISO 4762-M10x85-A2-70

Coding	Ports (ISO 228-1)
/5 BL...	A, B
	G 1

/5 AC...

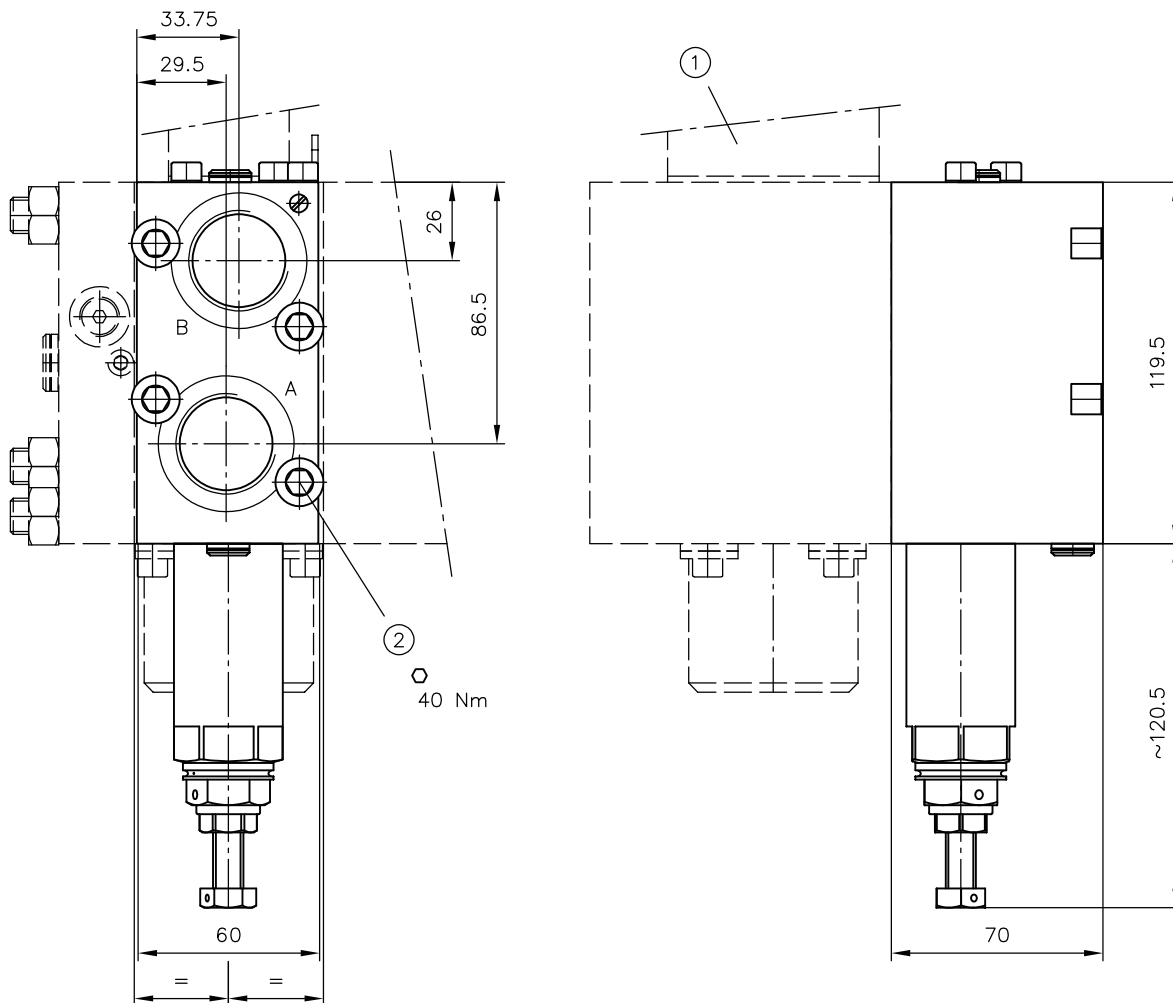

- 1 Directional valve section
- 2 Cylinder screw ISO 4762-M10x85-A2-70

Coding	Ports (ISO 228-1)
/5 AC...	A, B
	G 1

/5 BC...

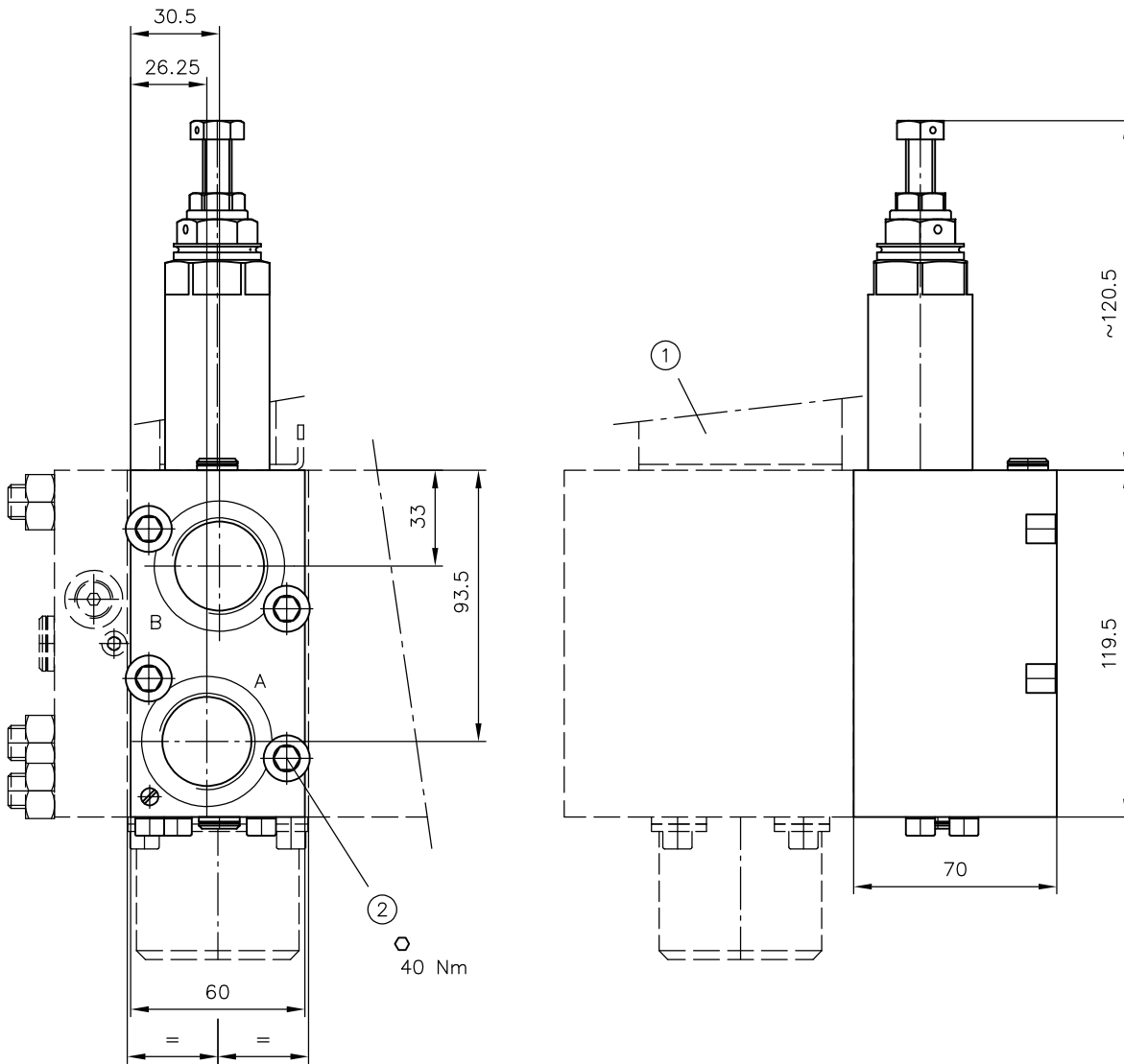

- 1 Directional valve section
- 2 Cylinder screws ISO 4762-M10x85-A2-70

Coding	Ports (ISO 228-1)
/5 BC...	A, B
	G 1

/5 DRH, /5 DRH A, /5 DRH B, /5 DRH VV
/UNF 5 DRH, /UNF 5 DRH A, /UNF 5 DRH B, /UNF 5 DRH VV

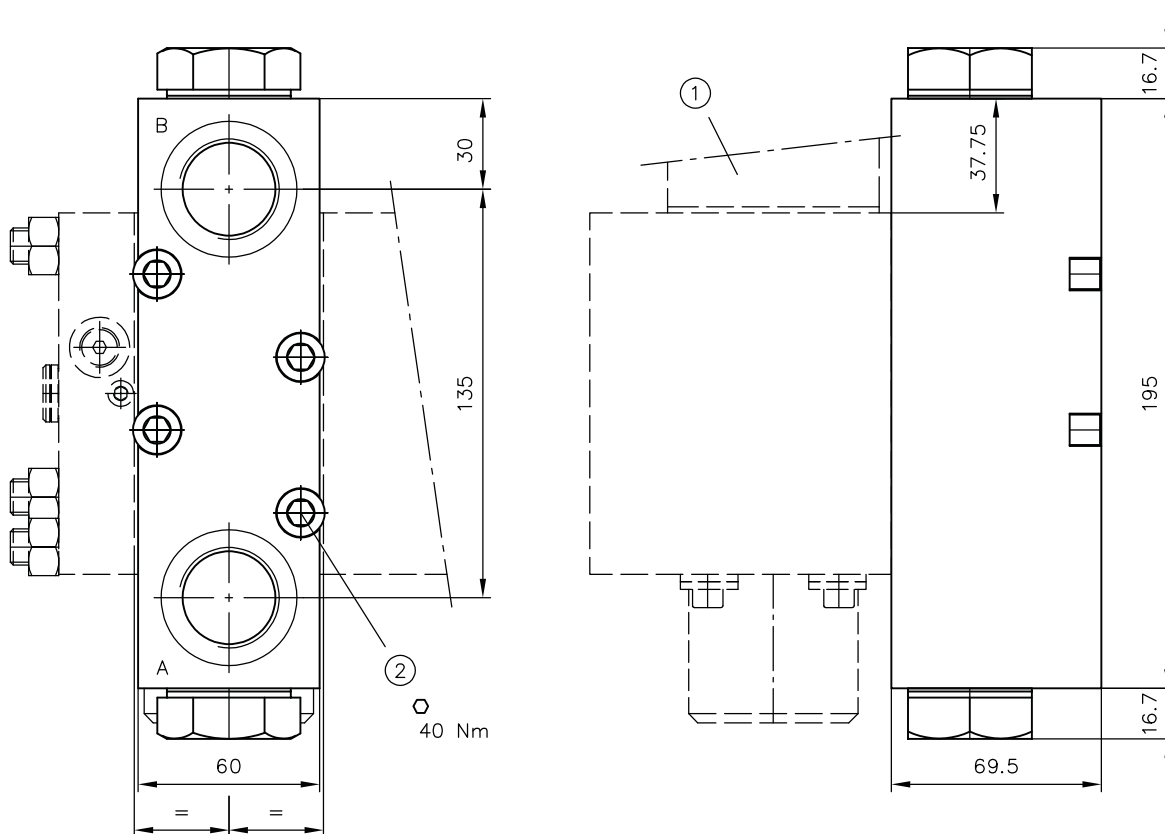

- 1 Directional valve section
2 Cylinder screws ISO 4762-M10x85-A2-70

Coding	Ports (ISO 228-1 or SAE J 514)
	A, B
/5 DRH /5 DRH A /5 DRH B /5 DRH VV	G 1
/UNF 5 DRH /UNF 5 DRH A /UNF 5 DRH B /UNF 5 DRH VV	1 5/16-12 UN-2B (SAE-16)

/5 RVV, /5 RSS, /5 RVX, /5 RSX, /5 RXV, /5 RXS
/UNF 5 RVV, /UNF 5 RSS, /UNF 5 RVX, /UNF 5 RSX, /UNF 5 RXV, /UNF 5 RXS

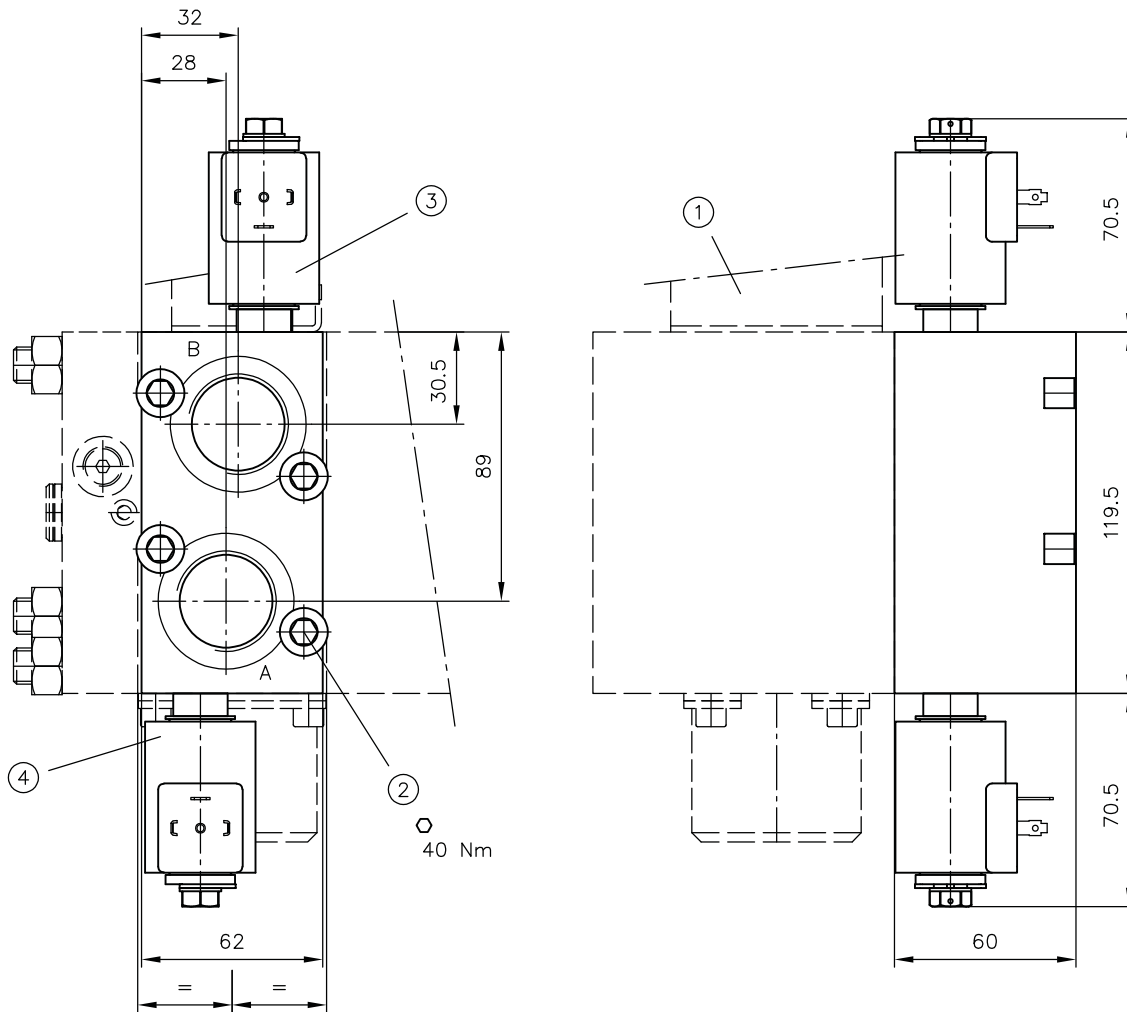

- 1 Directional valve section
- 2 Cylinder screws ISO 4762-M10x60-A2-70
- 3 Check valve type EM 22 v(S) omitted on type /5 RV(S)X
- 4 Check valve type EM 22 v(S) omitted on type /5 RXV(S)

Coding	Ports (ISO 228-1 or SAE J 514)
	A, B
/5 RVV /5 RSS /5 RVX /5 RSX /5 RXV /5 RXS	G 1
/UNF 5 RVV /UNF 5 RSS /UNF 5 RVX /UNF 5 RSX /UNF 5 RXV /UNF 5 RXS	1 5/16-12 UN-2B (SAE-16)

/54 DFA

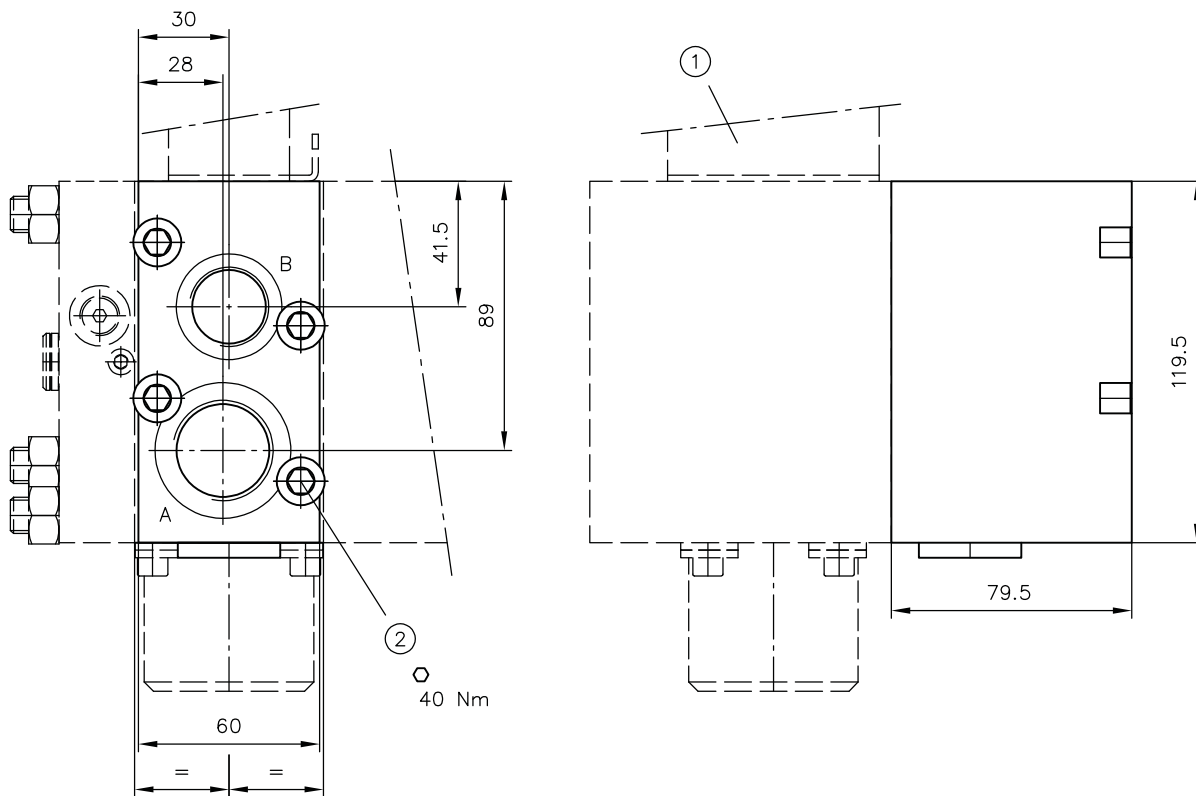

- 1 Directional valve section
- 2 Cylinder screws ISO 4762-M10x80-A2-70

Coding	Ports (ISO 228-1)	
	A	B
/54 DFA	G 1	G 3/4

/54 DFB

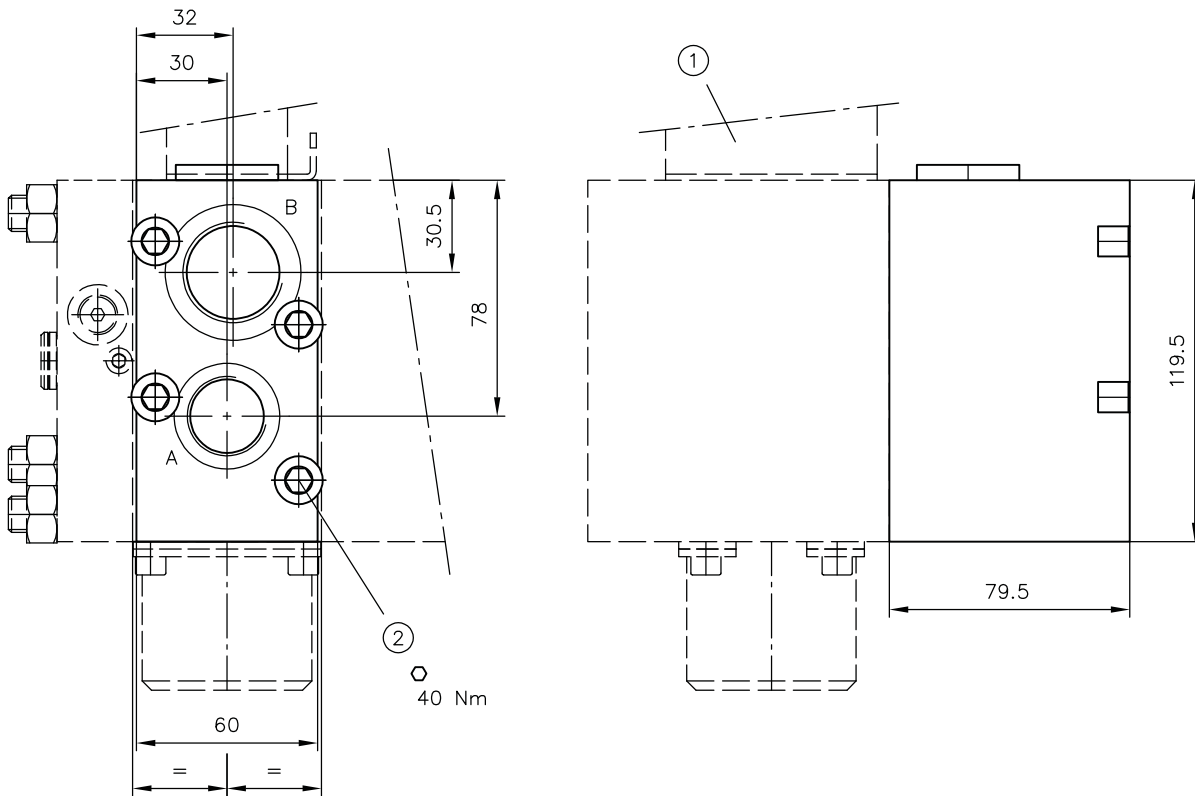

- 1 Directional valve section
- 2 Cylinder screws ISO 4762-M10x80-A2-70

Coding

Ports (ISO 228-1)

	A	B
/54 DFB	G 3/4	G 1

4.2.3 intermediate plate

As per Chapter 2.2.3, "Intermediate plate (on the consumer side)"

/Z 30, /Z 70

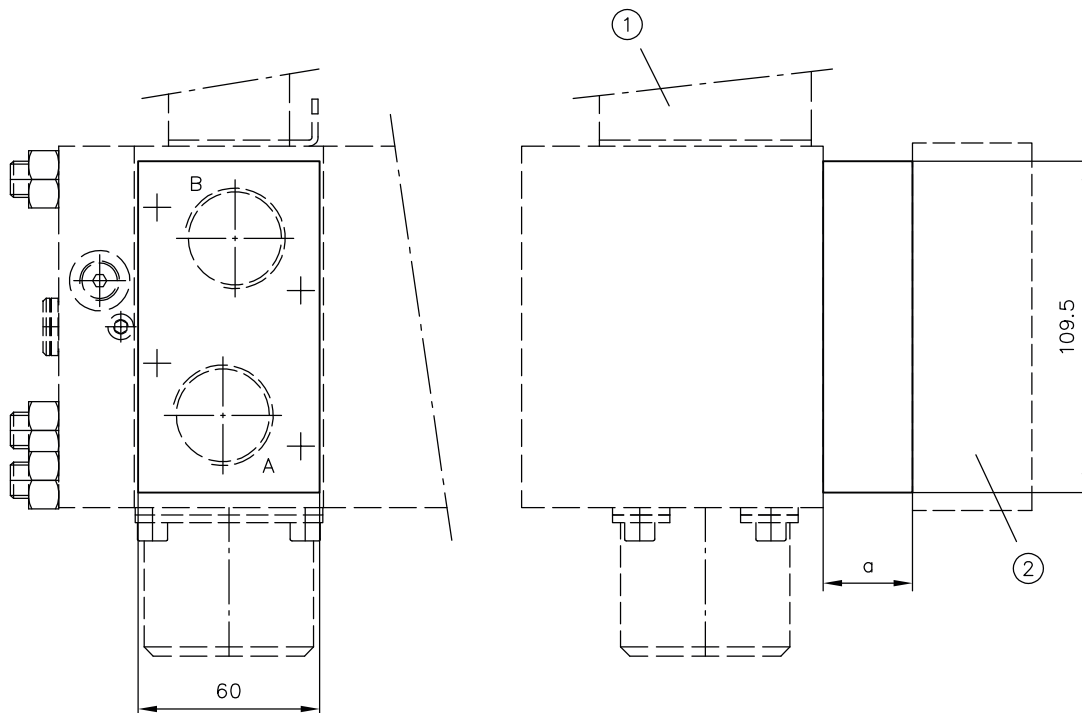

- 1 Directional valve section
- 2 Ancillary blocks

Coding	a
/Z 30	29,5
/Z 70	69,5

/Z ALW-...

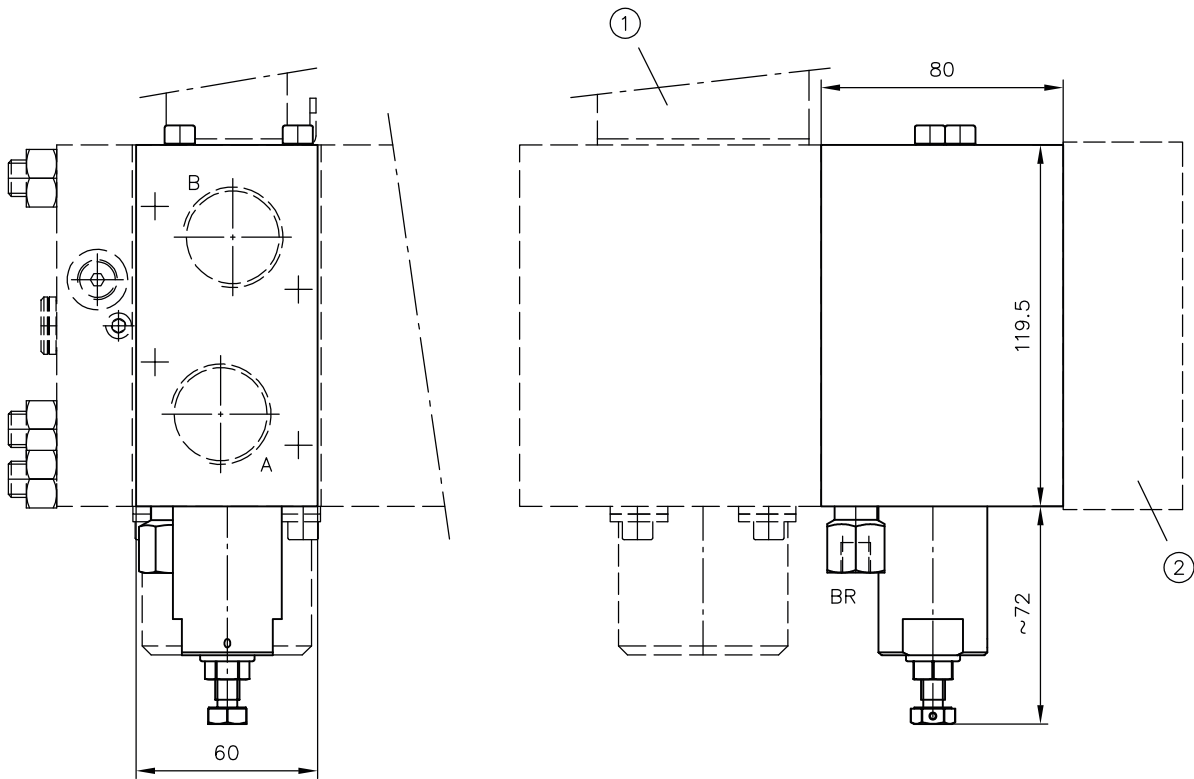

- 1 Directional valve section
- 2 Ancillary blocks

Ports (ISO 228-1)

BR	G 1/8
----	-------

/Z BLW-...

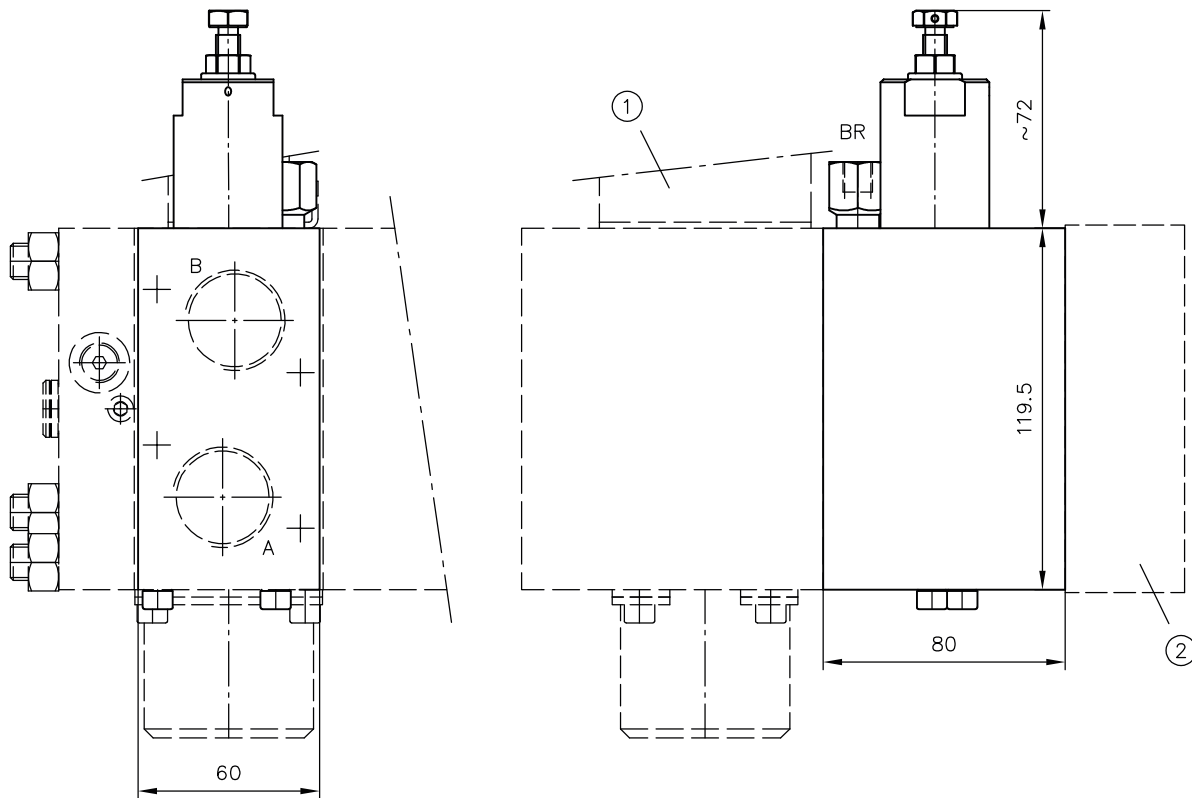

- 1 Directional valve section
- 2 Ancillary blocks

Ports (ISO 228-1)

BR G 1/8

/ZVV, /ZSS, /ZVX
/ZXV, /ZSX, /ZXS

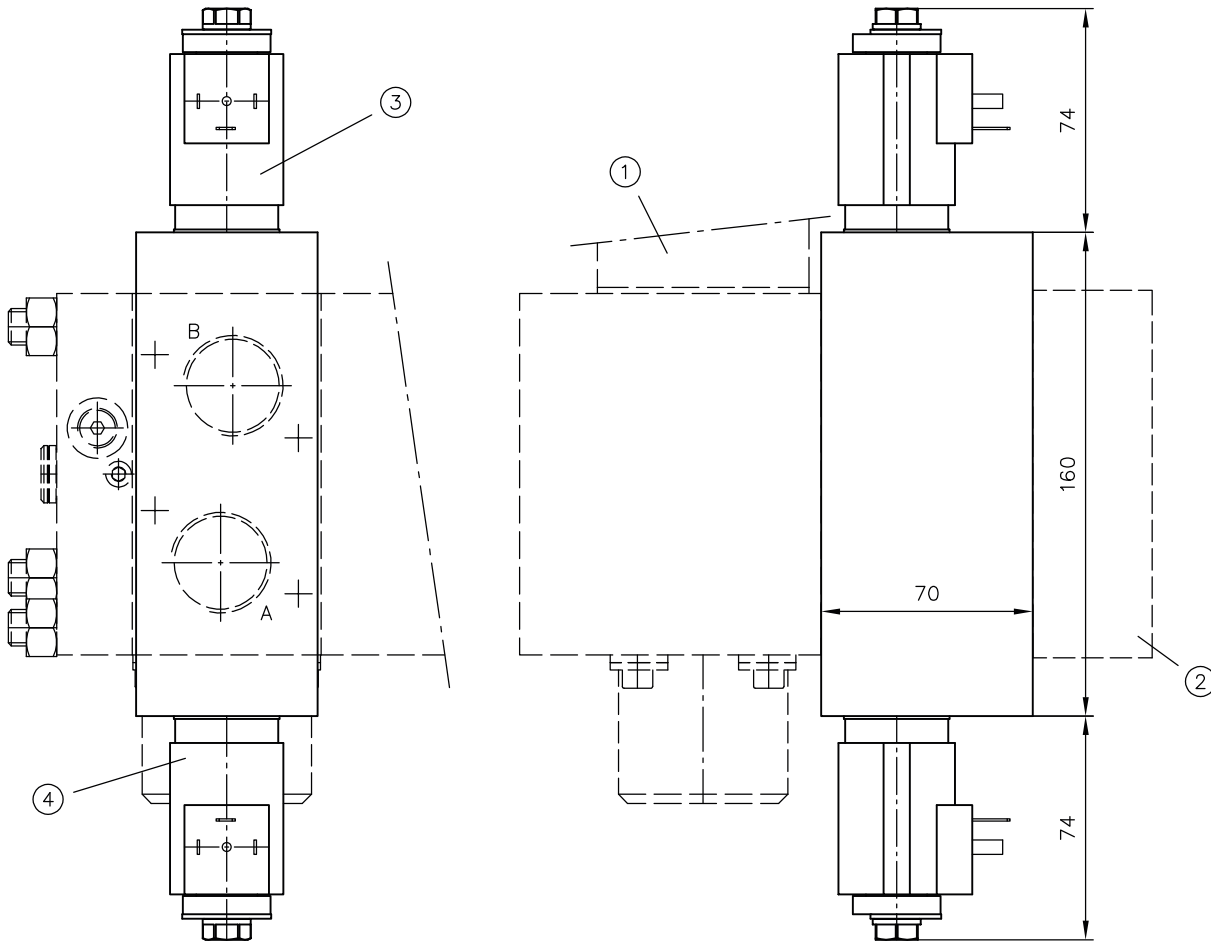

- 1 Directional valve section
- 2 Ancillary blocks
- 3 Check valve type EM 42 V(S) omitted on type /ZV(S)X
- 4 Check valve type EM 42 V(S) omitted on type /ZXV(S)

4.2.4 Series intermediate plate

As per Chapter 2.3, "Series intermediate plate"

ZPL 55/9
ZPL 55/9/XR
ZPL 55/15

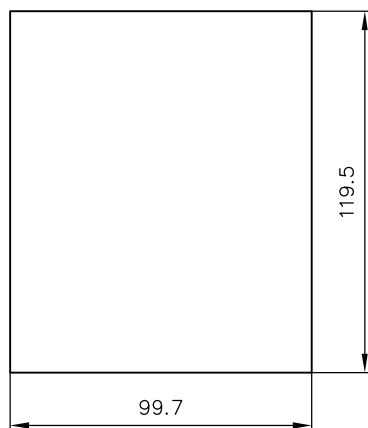
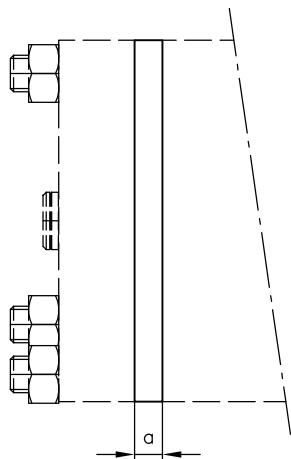

Coding	a
ZPL 55/9	9,2
ZPL 55/9/XR	9,2
ZPL 55/15	15

ZPL 5 P6 R6
ZPL 5 P6 RX6
ZPL 5 P6 R6/R1

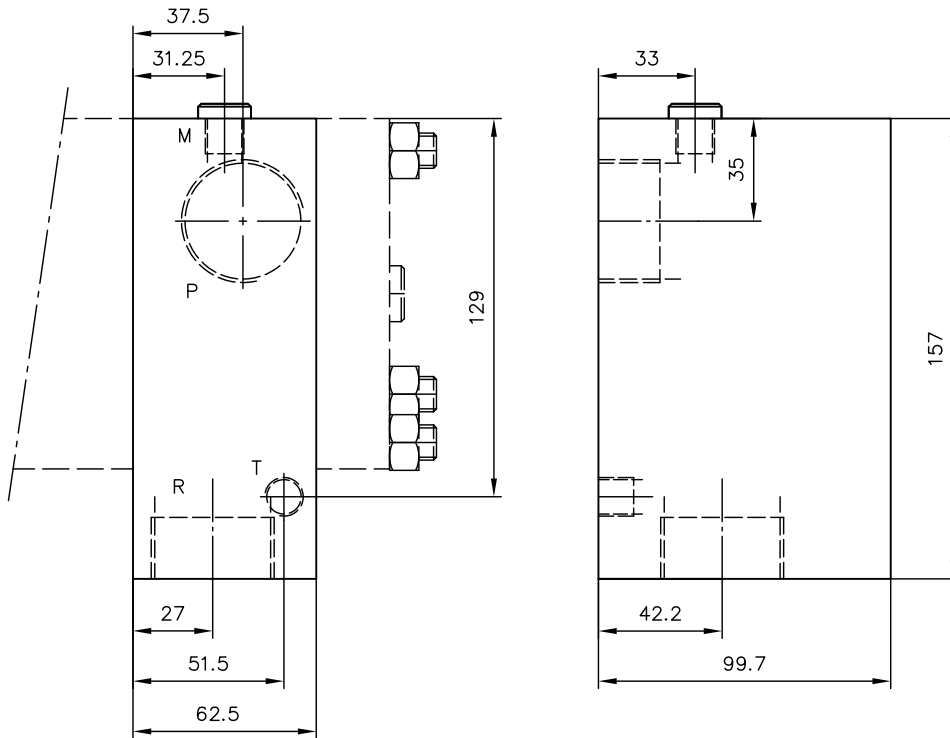

1 without port M on ZPL 5 P6 R6/R1

Coding	Ports (ISO 228-1)	
	P, R	M, T
ZPL 5 P6 R6		
ZPL 5 P6 RX6	G 1 1/4	G 1/4
ZPL 5 P6 R6/R1		

ZPL 5 S/H
ZPL 5 V/H

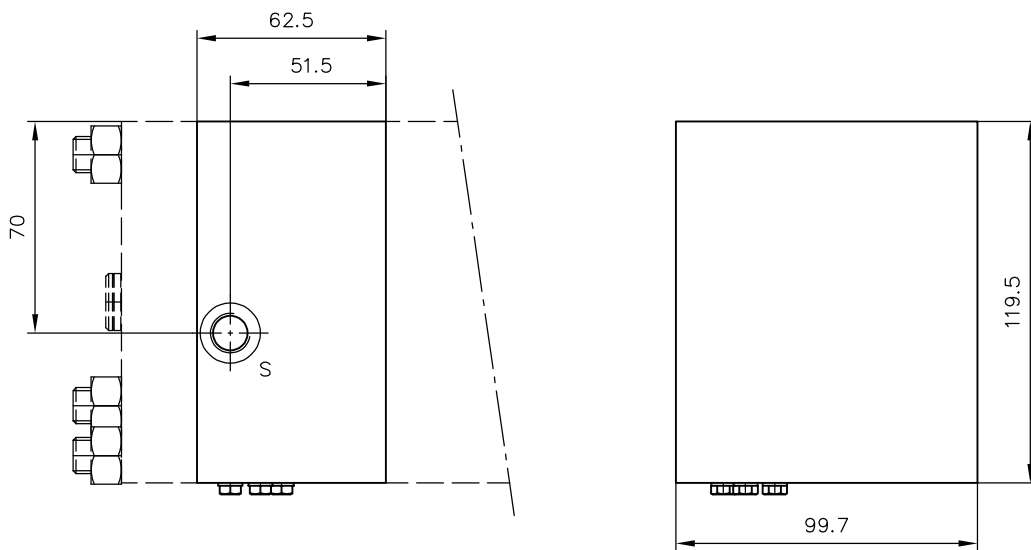

Coding

Ports (ISO 228-1)

ZPL 5 S/H
ZPL 5 V/H

S

G 1/4

ZPL 5 S/E
ZPL 5 V/E

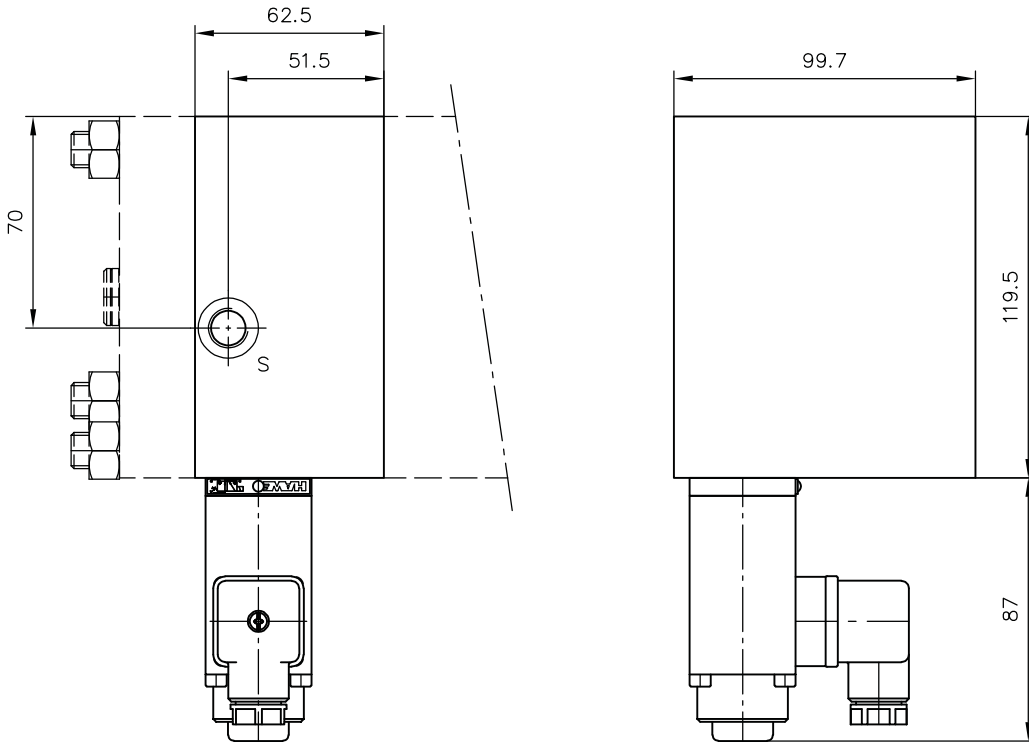

Coding

Ports (ISO 228-1)

S

ZPL 5 S/E
ZPL 5 V/E

G 1/4

ZPL 50 ...
ZPL 50 T ...

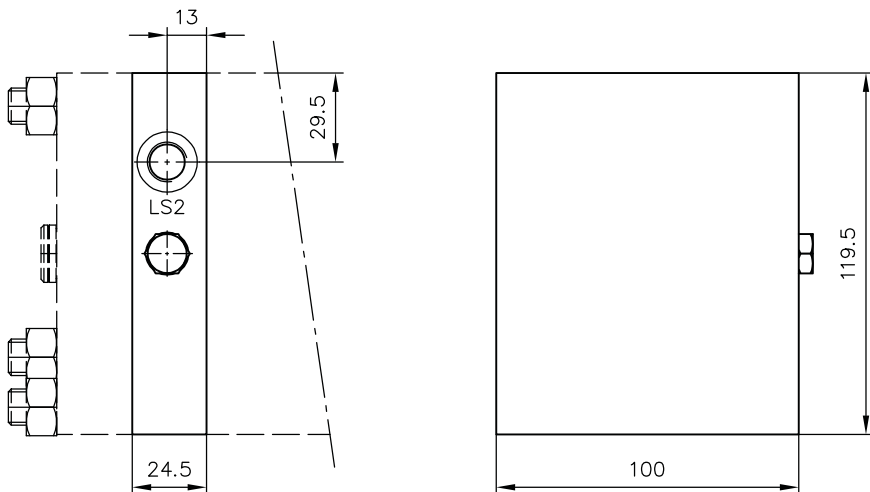

Coding

Ports (ISO 228-1)

LS2

ZPL 50 ...
ZPL 50 T ...

G 1/4

ZPL 531
ZPL 531/RB
ZPL 531/XR
ZPL 531/RB XR

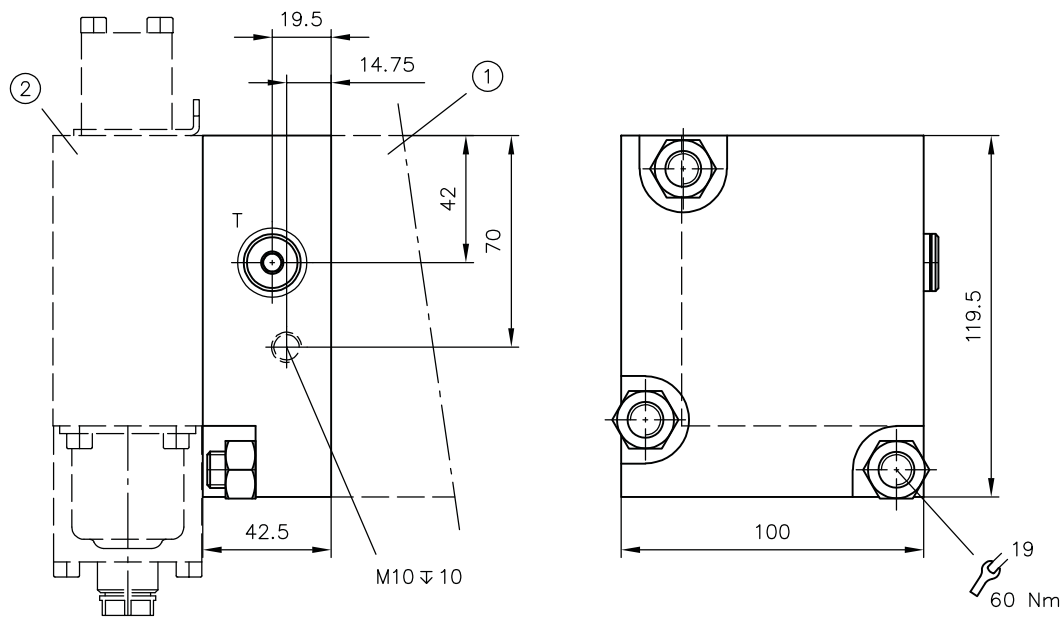

- 1 Directional valve section PSL 5
- 2 Directional valve section PSL 3

Coding

Ports (ISO 228-1)

T

ZPL 531
ZPL 531/RB
ZPL 531/XR
ZPL 531/RB XR

G 1/4

ZPL 521

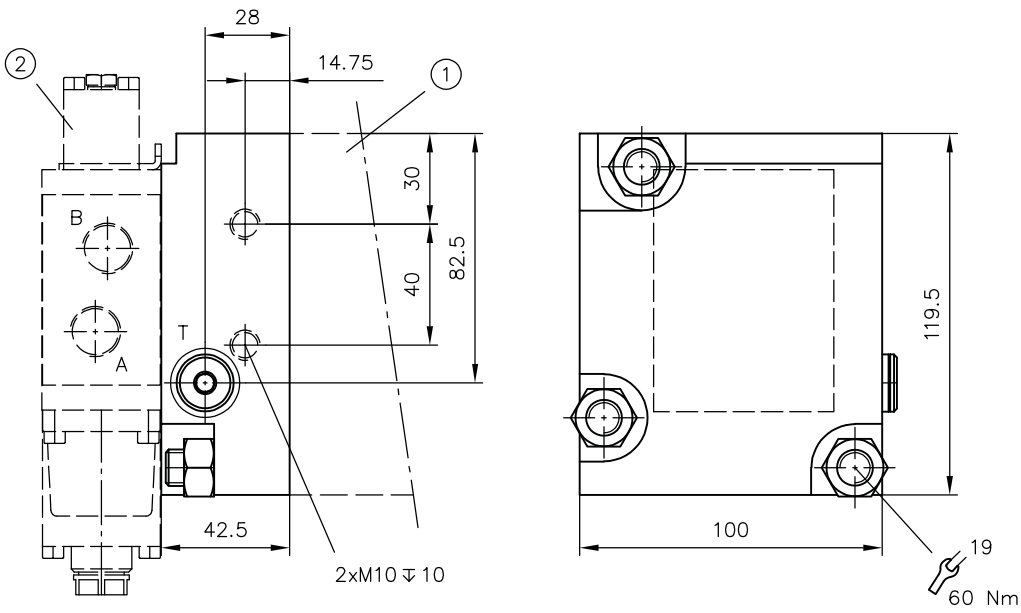

- 1 Directional valve section PSL 5
- 2 Directional valve section PSL 2

Coding	Ports (ISO 228-1)
	T
ZPL 521	G 1/4

4.2.5 End plate

As per Chapter 2.4, "End plate"

E1, E1 UNF

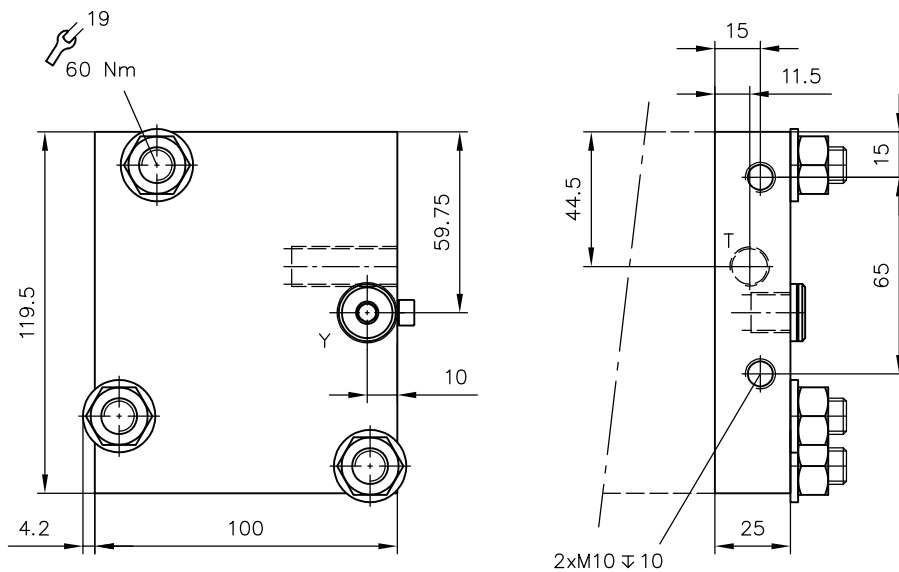

- T - open
- Y - closed

E 2

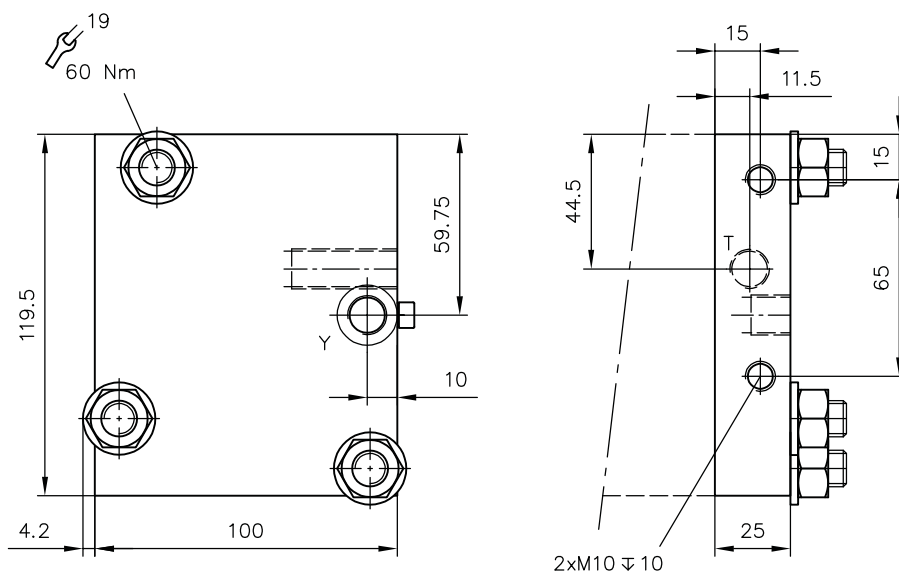

- T - open
- Y - open

Coding	Ports (ISO 228-1 or SAE J 514)
E 1, E 2	T, Y
E 1 UNF	G 1/4
	7/16-UNF-2B (SAE-4)

E 4, E 4 UNF

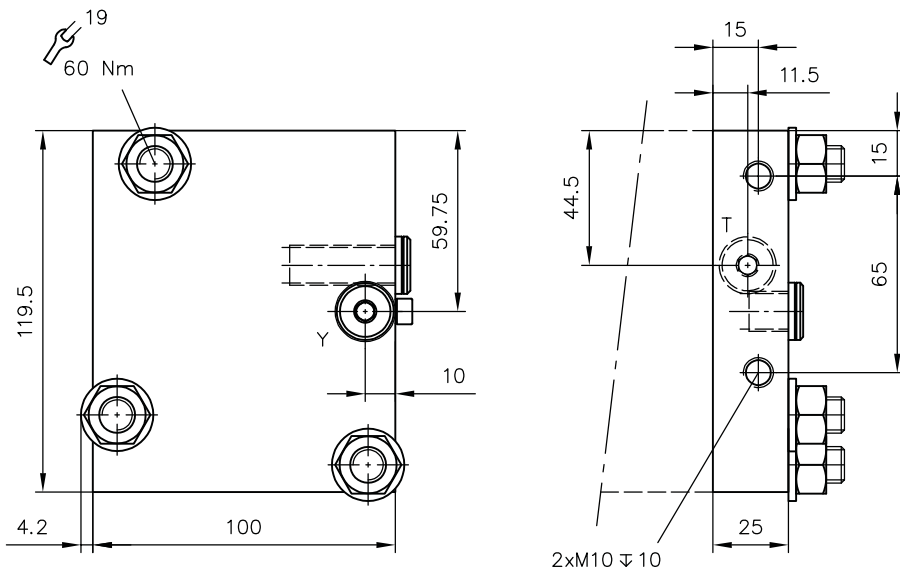

- T - sealed
- Y - sealed

E 5

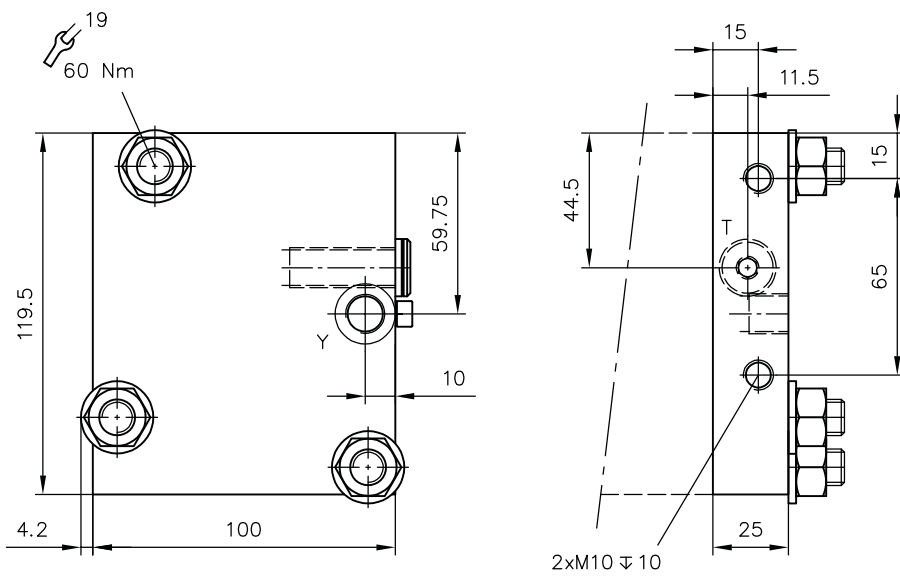

- T - sealed
- Y - open

Coding	Ports (ISO 228-1 or SAE J 514)
E 4, E 5	T, Y
E 4, E 5	G 1/4
E 4 UNF	7/16-UNF-2B (SAE-4)

E 3

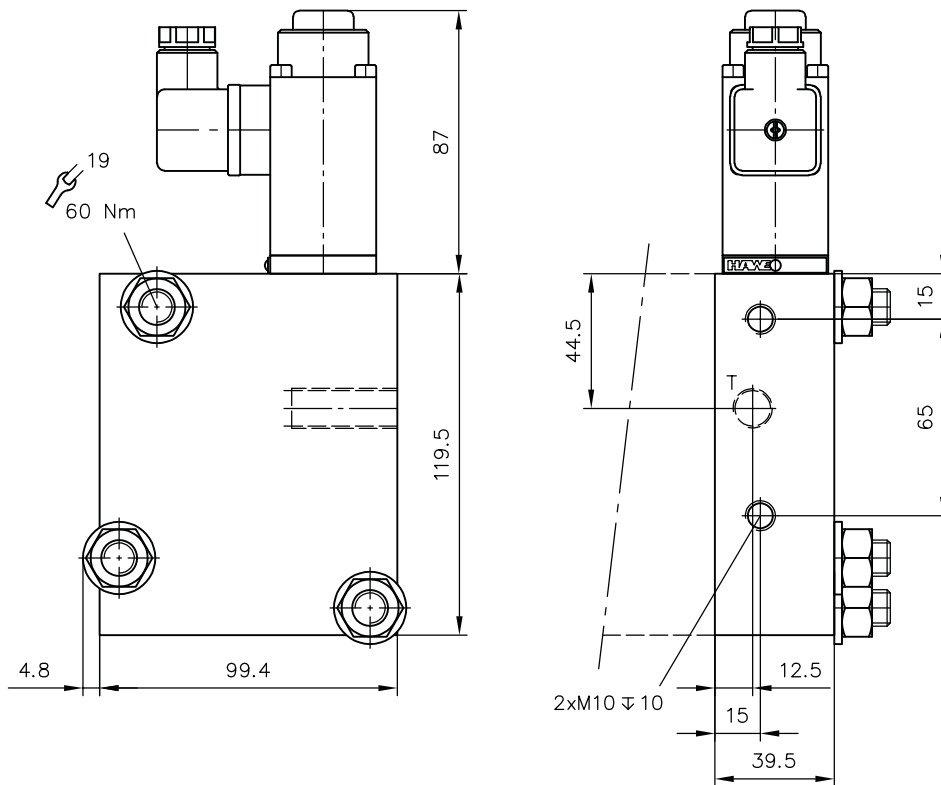

■ T - open

Coding	Ports (ISO 228-1)
E 3	T G 1/4

E 6

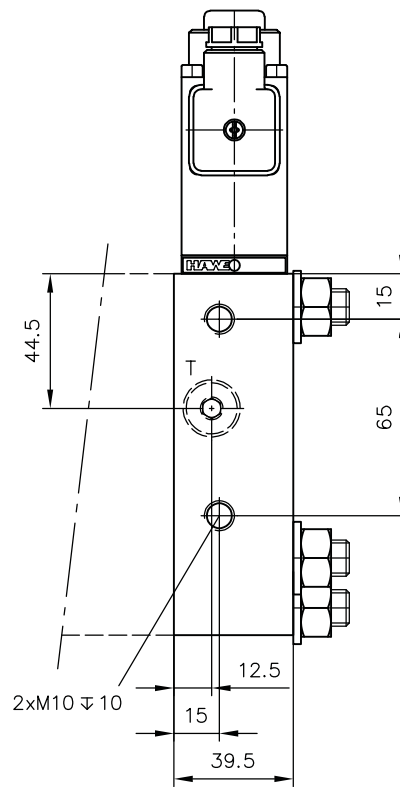
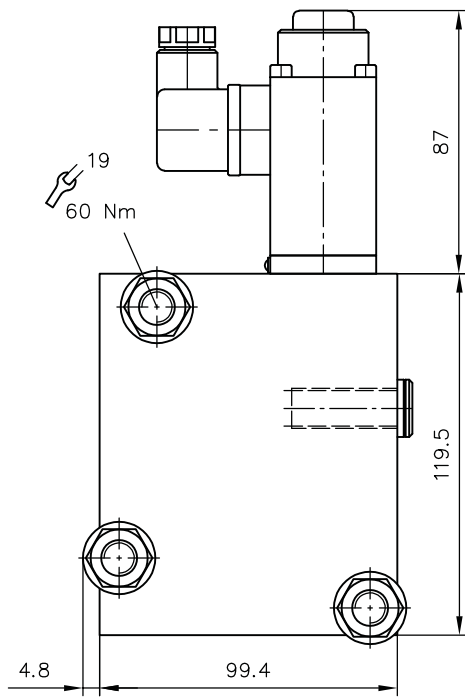

- T - sealed

E 7

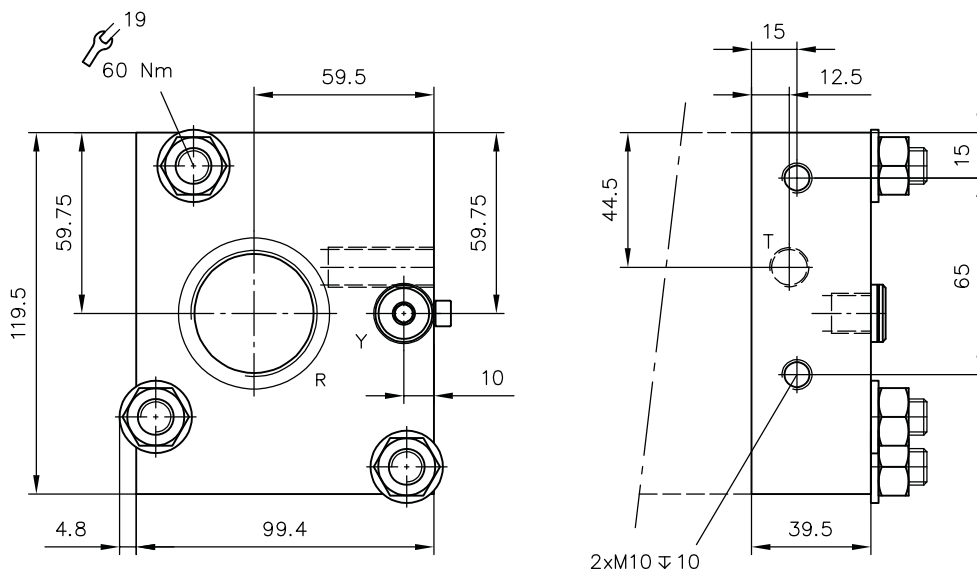

- R - open
- T - open
- Y - closed

E 8

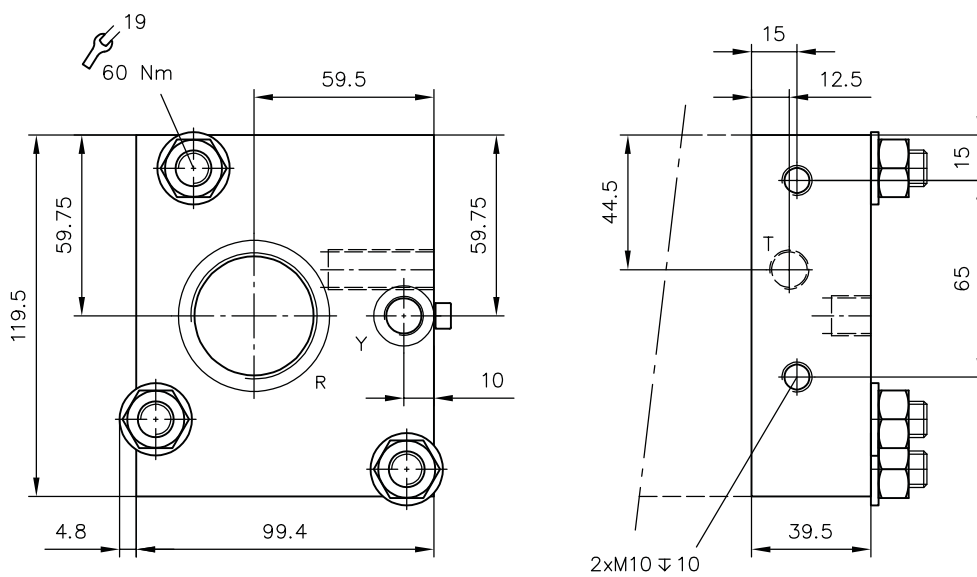

- R - open
- T - open
- Y - open

Coding

Ports (ISO 228-1)

	T, Y	R
E 7, E 8	G 1/4	G 1 1/4

E 9

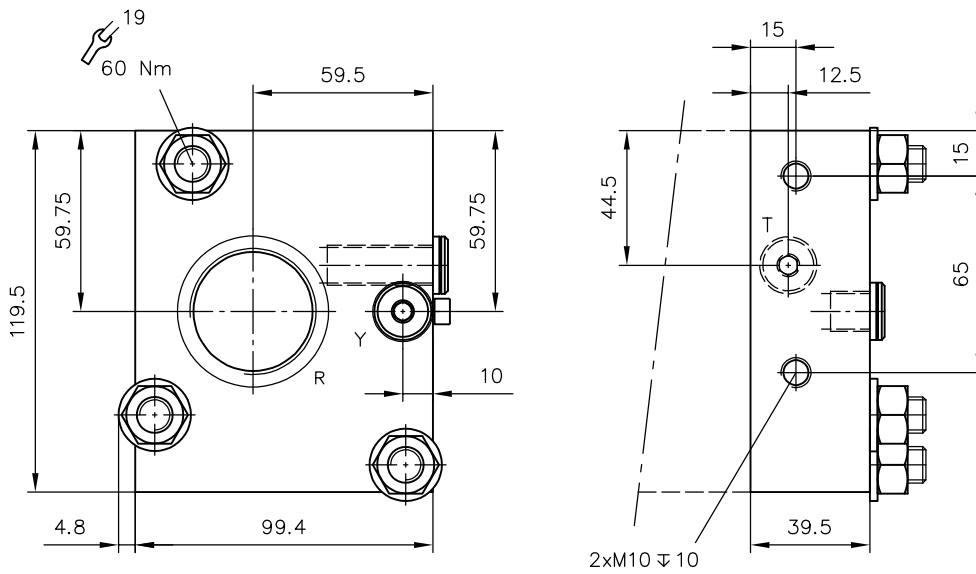

- R - open
- T - sealed
- Y - sealed

E 10

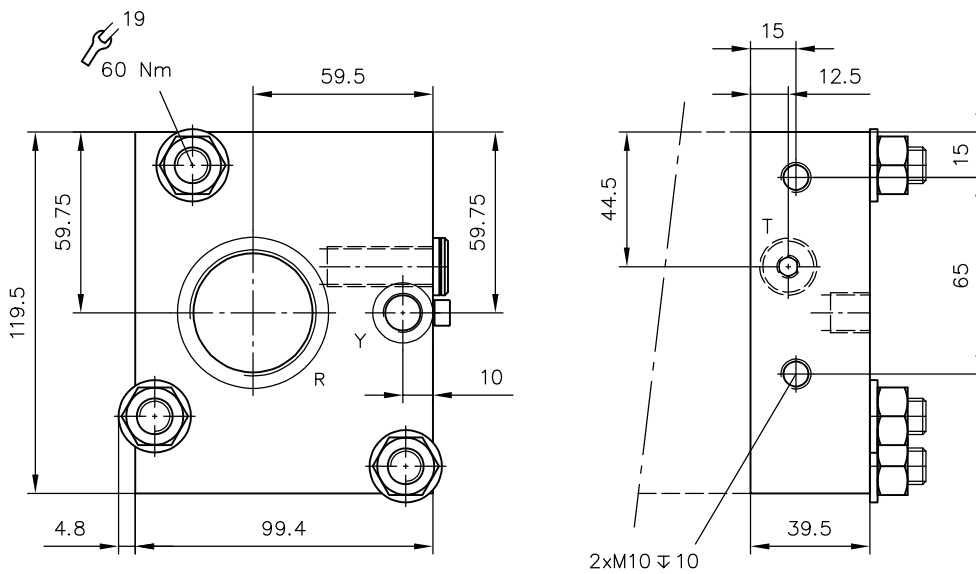

- R - open
- T - sealed
- Y - open

Coding

Ports (ISO 228-1)

	T, Y	R
E 9, E 10	G 1/4	G 1 1/4

E 7 A

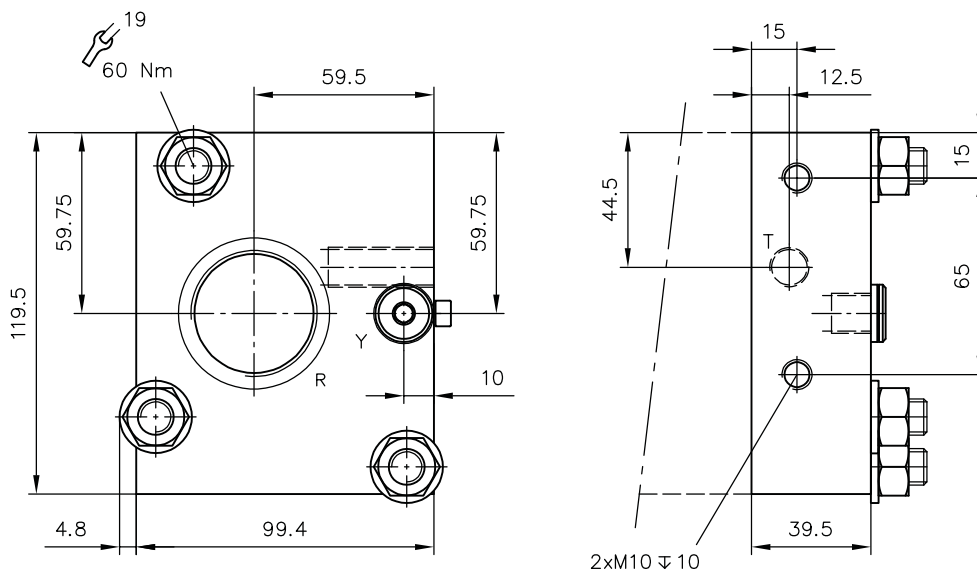

- R - open
- T - open
- Y - closed

E 8 A

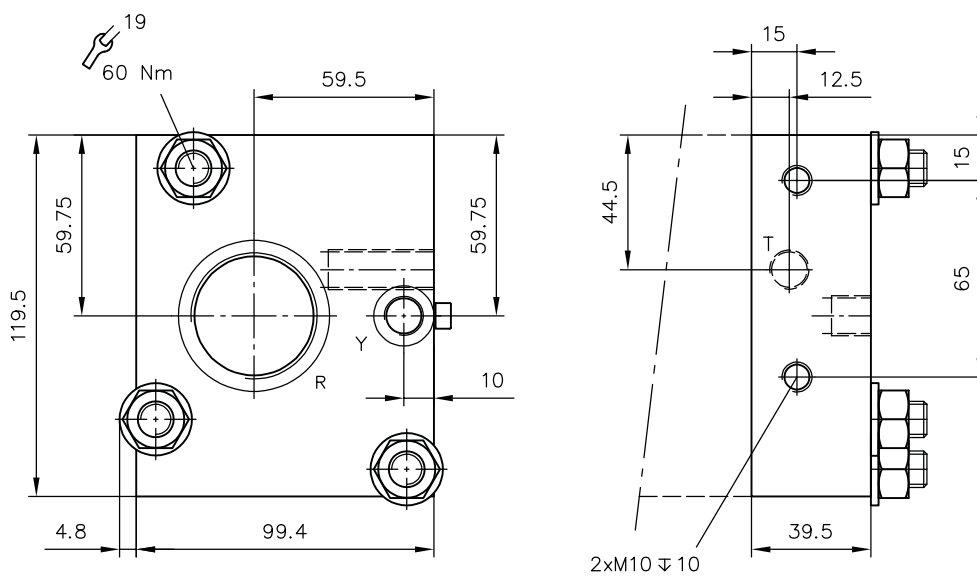

- R - open
- T - open
- Y - open

Coding

Ports (ISO 228-1)

	Ports (ISO 228-1)	
	T, Y	R
E 7 A	G 1/4	G 1 1/4
E 8 A	G 1/4	G 1 1/4

E 13, E 13 UNF

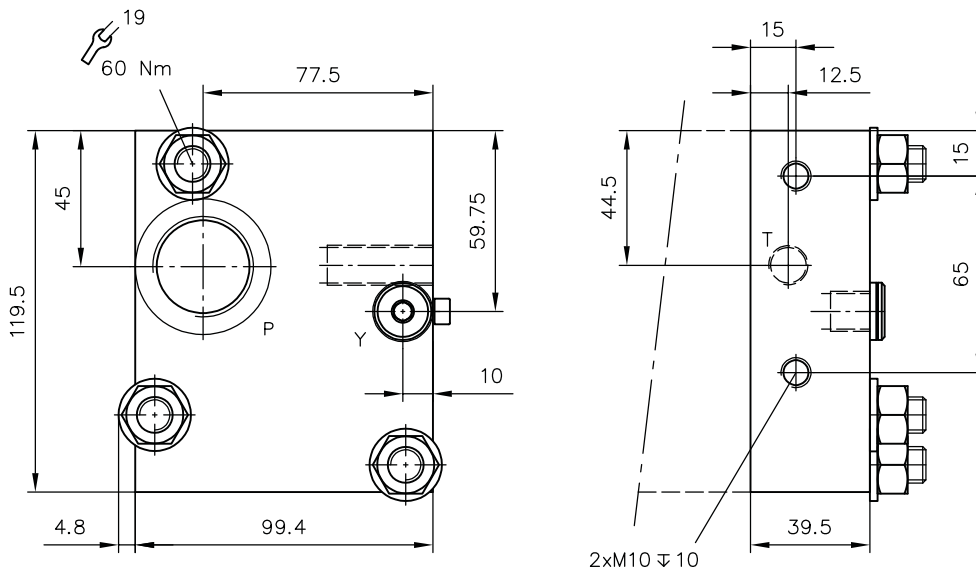

- P - open
- T - open
- Y - closed

E 14, E 14 UNF

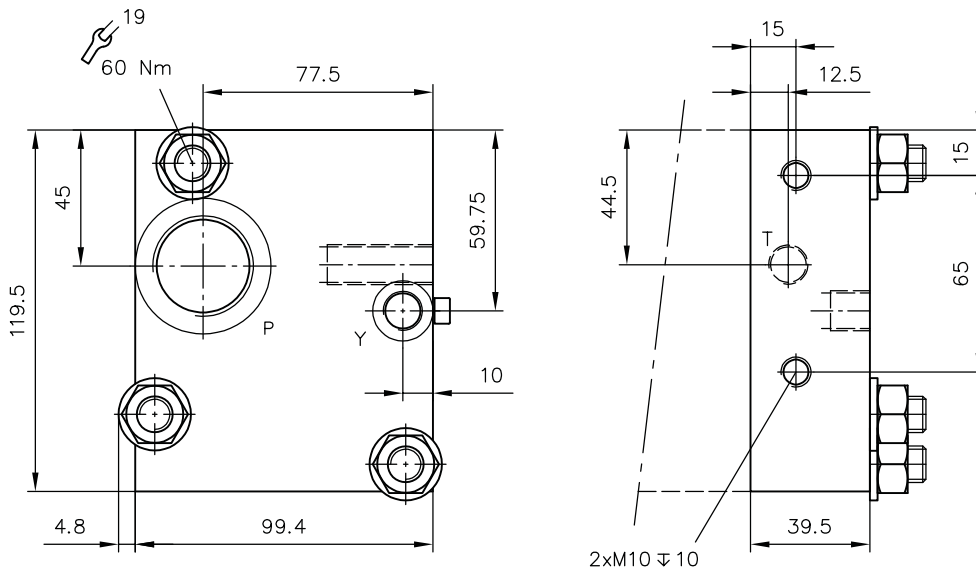

- P - open
- T - open
- Y - open

Coding

Ports (ISO 228-1 or SAE J 514)

	T, Y	P
E 13 E 14	G 1/4	G 1
E 13 UNF E 14 UNF	7/16-UNF-2B (SAE-4)	1 5/16-12 UN-2B (SAE-16)

E 15, E 15 UNF

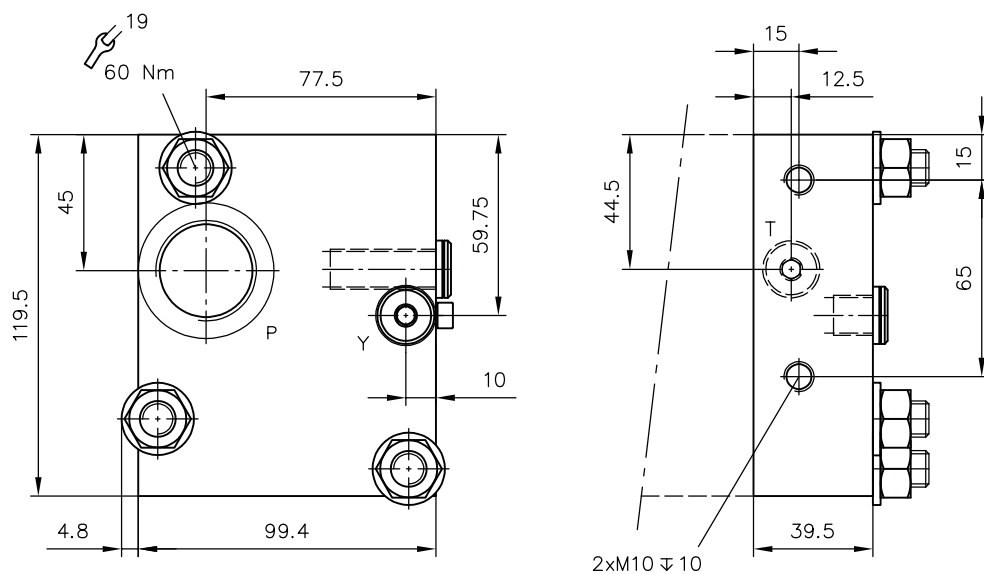

- P - open
- T - sealed
- Y - sealed

E 16, E 16 UNF

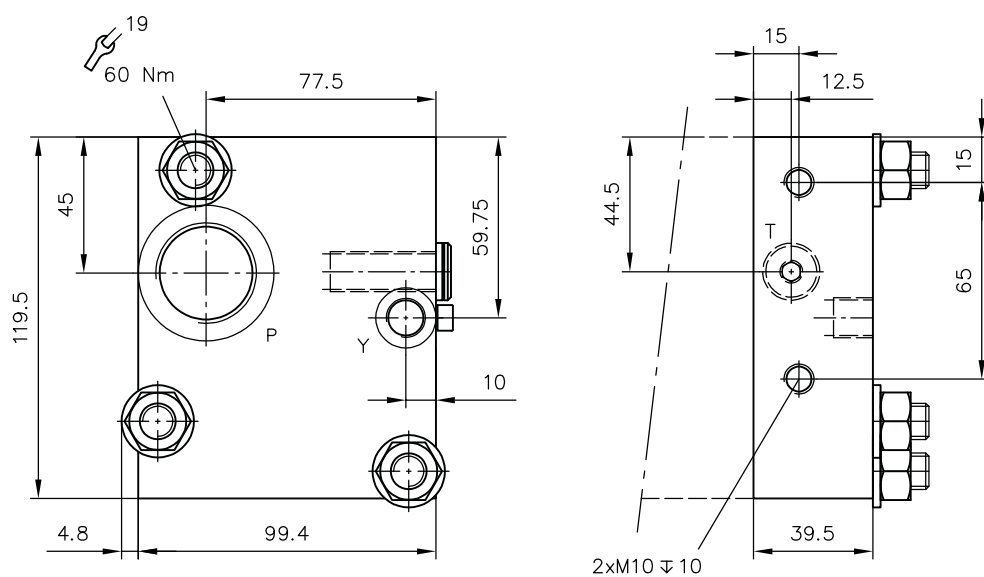

- P - open
- T - sealed
- Y - open

Coding

Ports (ISO 228-1 or SAE J 514)

	T, Y	P
E 15 E 16	G 1/4	G 1
E 15 UNF E 16 UNF	7/16-UNF-2B (SAE-4)	1 5/16-12 UN-2B (SAE-16)

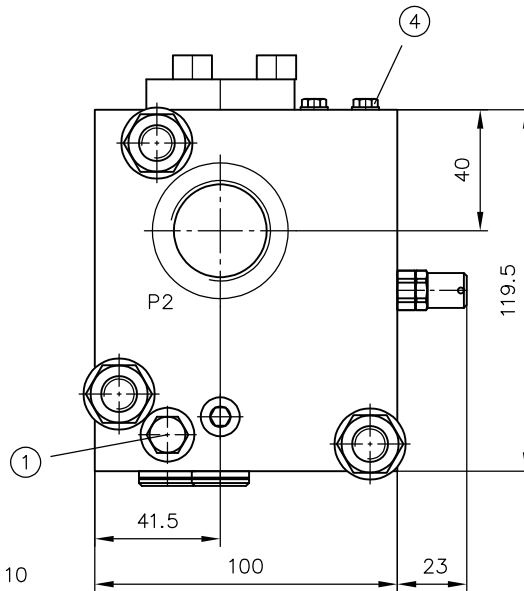
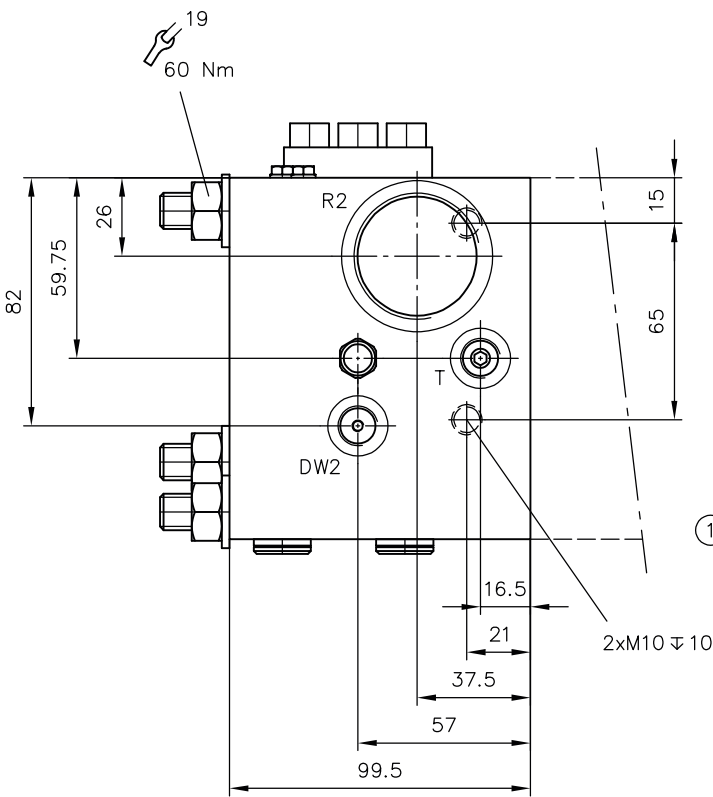
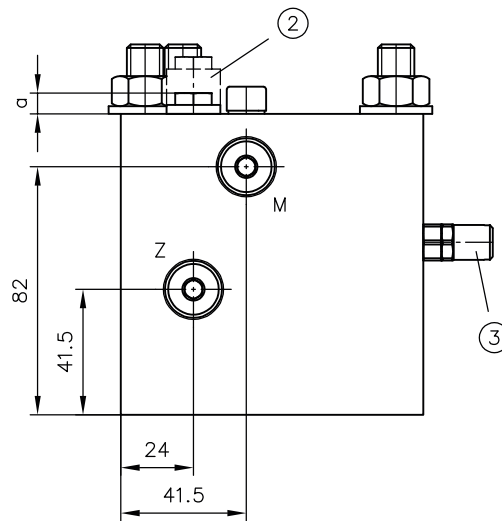

- 1 Internal control oil supply without coding or coding 1
- 2 Internal control oil supply coding 2
- 3 Pressure-limiting valve
- 4 Mounting point for additional valve for LS relief or LS pressure limitation

- T - open
- Y - sealed
- P2 - open
- R2 - open

Coding	a
without coding	6,5
1	6,5
2	18,4

Coding	Ports (ISO 228-1)		
	P2	R2	Z, M, DW2, T
E 1 PSL 56.../...	G 1	G 1 1/4	G 1/4

E 4 PSL 56.../...

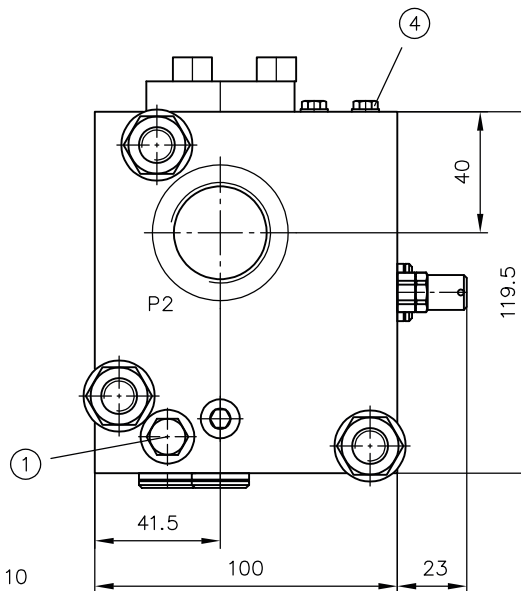
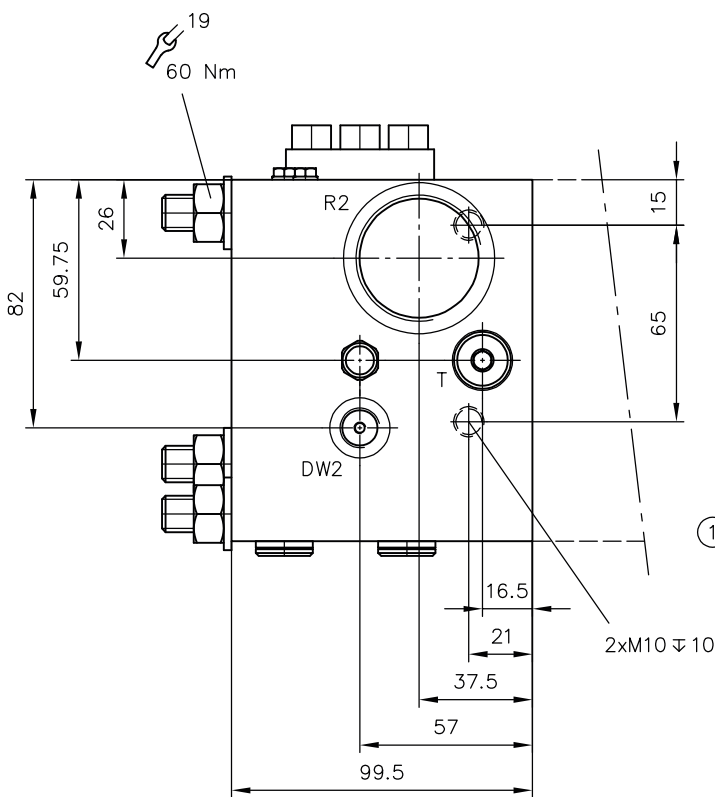
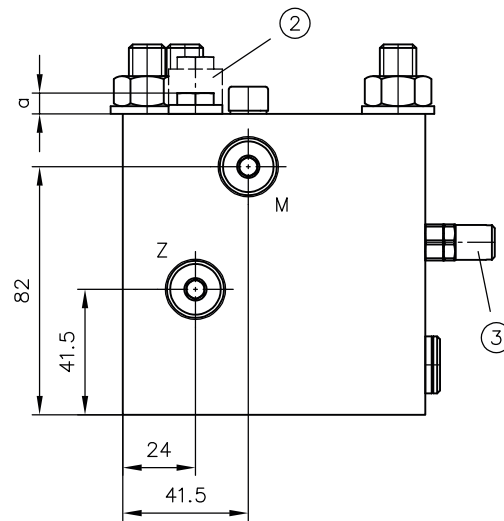

- 1 Internal control supply without coding or coding 1
- 2 Internal control supply coding 2
- 3 Pressure-limiting valve
- 4 Mounting point for additional valve for LS relief or LS pressure limitation

- T - sealed
- Y - sealed
- P2 - open
- R2 - open

Coding	a
without coding	6,5
1	6,5
2	18,4

Coding	Ports (ISO 228-1)		
	P2	R2	Z, M, DW2, T
E 4 PSL 56.../...	G 1	G 1 1/4	G 1/4

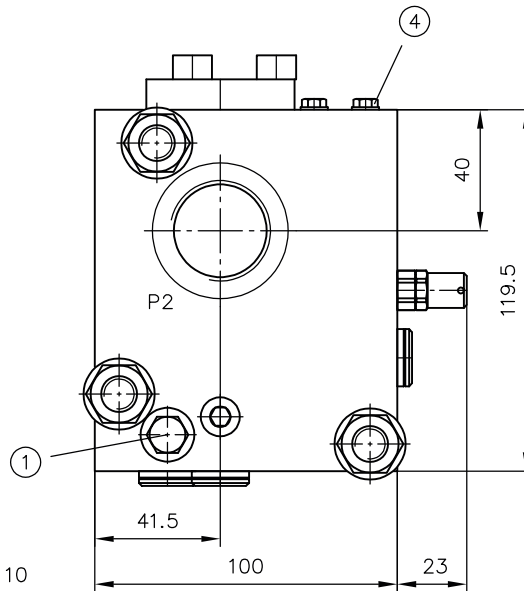
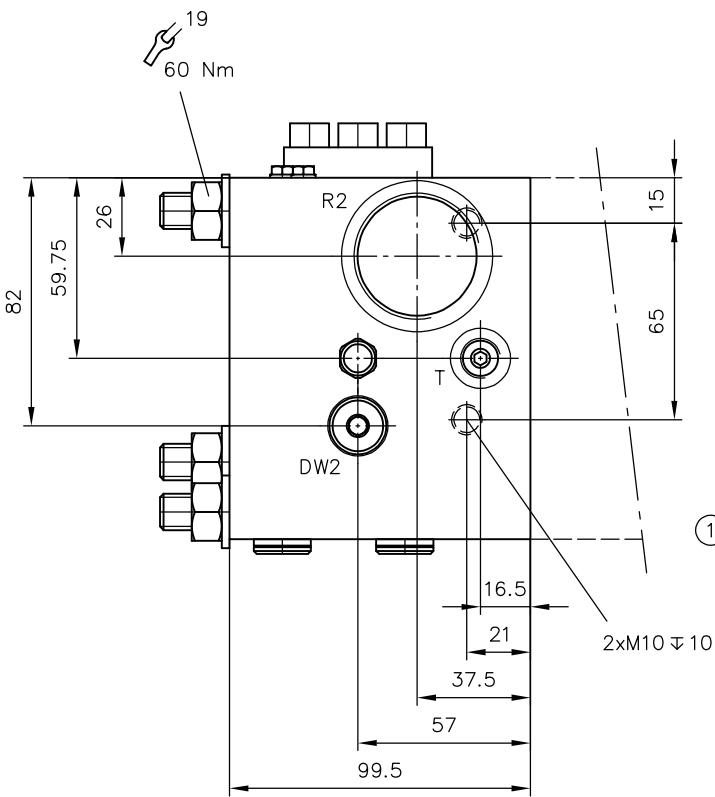
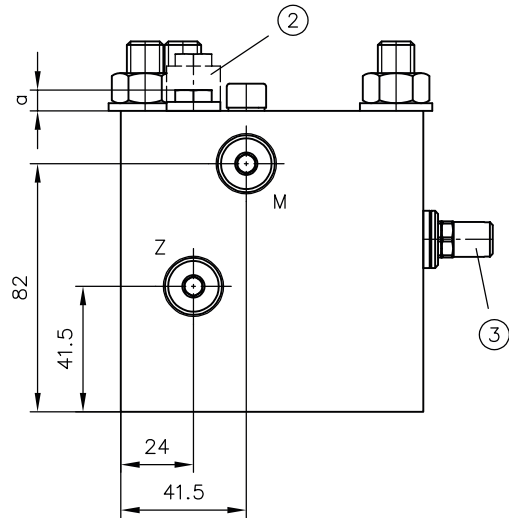

- 1 Internal control oil supply without coding or coding 1
- 2 Internal control oil supply coding 2
- 3 Pressure-limiting valve
- 4 Mounting point for additional valve for LS relief or LS pressure limitation

- T - open
- Y - sealed
- P2 - open
- R2 - open

Coding	a
without coding	6,5
1	6,5
2	18,4

Coding	Ports (ISO 228-1)		
	P2	R2	Z, M, DW2, T
E 1 PSV 56.../...	G 1	G 1 1/4	G 1/4

E 4 PSV 56.../...

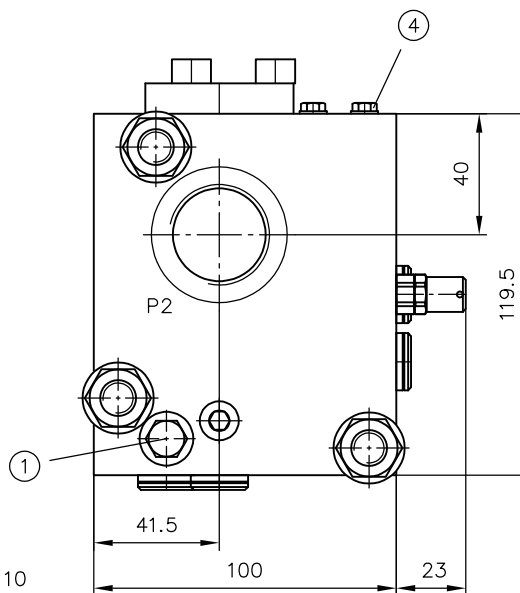
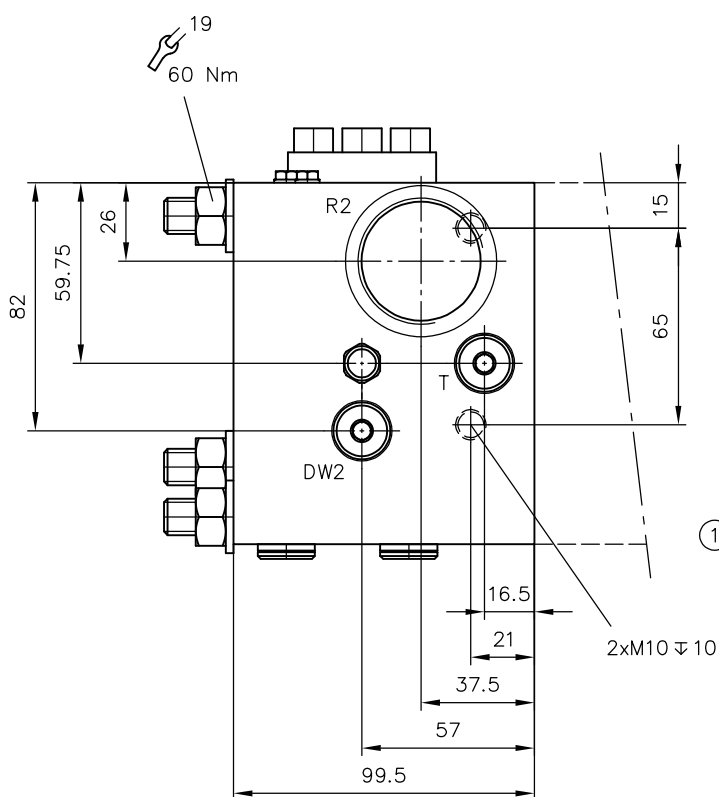
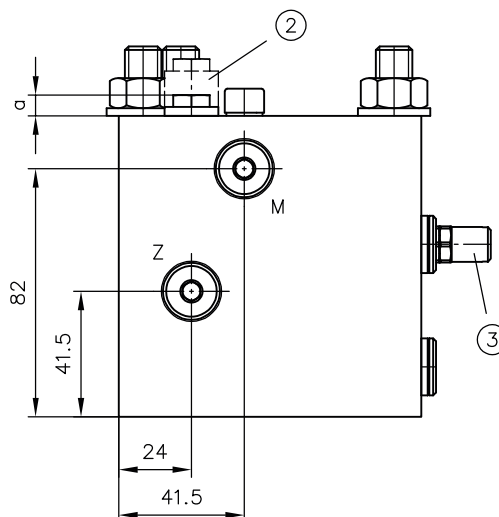

- 1 Internal control oil supply without coding or coding 1
- 2 Internal control oil supply coding 2
- 3 Pressure-limiting valve
- 4 Mounting point for additional valve for LS relief or LS pressure limitation

- T - sealed
- Y - sealed
- P2 - open
- R2 - open

Coding	a
without coding	6,5
1	6,5
2	18,4

Coding	Ports (ISO 228-1)		
	P2	R2	Z, M, DW2, T
E 4 PSV 56.../...	G 1	G 1 1/4	G 1/4

Observe the document B 5488 "General operating instructions for assembly, commissioning, and maintenance."

5.1 Intended use

This product is intended exclusively for hydraulic applications (fluid technology).

The user must observe the safety measures and warnings in this document.

Essential requirements for the product to function correctly and safely:

- ▶ All information in this documentation must be observed. This applies in particular to all safety measures and warnings.
- ▶ The product must only be assembled and put into operation by specialist personnel.
- ▶ The product must only be operated within the specified technical parameters described in detail in this document.
- ▶ All components must be suitable for the operating conditions when using an assembly.
- ▶ The operating instructions for the components, assemblies and the specific complete system must also always be observed.

If the product can no longer be operated safely:

1. Remove the product from operation and mark it accordingly.
 - ✓ It is then not permitted to continue using or operating the product.

5.2 Assembly information

The product must only be installed in the complete system with standard and compliant connection components (screw fittings, hoses, pipes, fixtures etc.).

The product must be shut down correctly prior to disassembly (in particular in combination with hydraulic accumulators).



DANGER

Sudden movement of the hydraulic drives when disassembled incorrectly

Risk of serious injury or death

- ▶ Depressurise the hydraulic system.
- ▶ Perform safety measures in preparation for maintenance.

5.2.1 Attachment

The valve bank must be mounted to the frame or base of the machine in such a way that no stress is induced. Three screws and elastic washers between the bank and the frame are recommended for attachment.

5.2.2 Piping

All fittings used must utilise deformable seals. The recommended tightening torque values must not be exceeded.

5.2.2.1 Reflux piping routed externally to the tank

If the reflux line from the consumer is routed externally back to the tank, this may impair the film of lubrication between the spool block and spool valve between R(B) and Z(B).

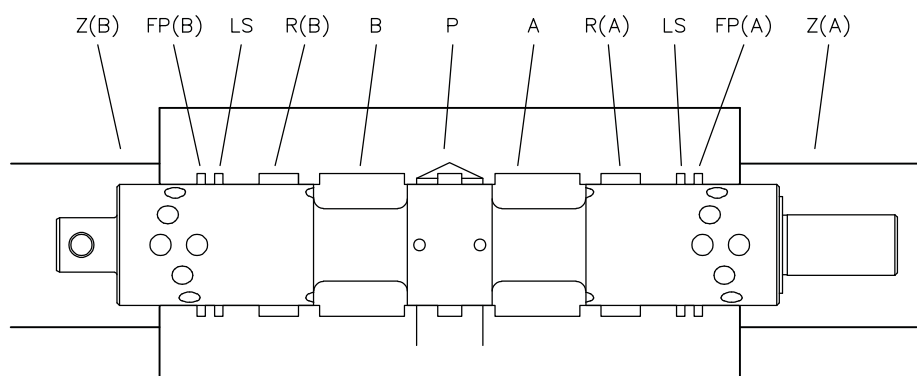

This could lead to a higher level of wear if the following conditions are also fulfilled:

- A consumer is actuated on a sustained basis for longer than 10 minutes.
- These three configurations apply
 - ▶ without LS pressure limitation ([Chapter 2.2.1.7](#))
 - ▶ without LS relief or LS pressure limitation coding ([Chapter 2.2.1.8](#))
 - ▶ without LS port for external limitation ([Chapter 2.2.1.9](#))

Recommendation for improving the lubrication in this case:

- Pre-load the reflux in PSL/PSV(max. 5 bar)
- Valve section with one of these three functions
 - ▶ LS pressure limitation
 - AB
 - A...B...
 - B...
 - C...
 - ▶ LS relief or LS pressure limitation
 - F0
 - F...
 - ▶ LS port for external limitation
 - S
 - S1
 - X
 - XXH
- On valve sections ([Chapter 2.2.1.3](#)) with code 8 and code 81, do not use dither.

5.2.3 Converting the connection block from PSL to PSV

Connection block type PSL 5(6)...-5 or PSL UNF 6..-5 can be converted into a connection block for variable pump systems at any time (the correct type is then type PSV 5(6) S../..-5 or PSV UNF 6 S). To do so, change or swap the parts listed below.

NOTICE

The screw (order no. 6380 013) / carburettor orifice M4x0.6 are glued in place using liquid threadlocker. During the conversion process, secure the parts against coming loose again. The conversion cannot be performed for type PSL 5(6) U(H) or PSL 6 Y as the integrated valve combinations prohibit any combinations with variable pump systems. If type PSV is to be converted to type PSL, the existing tapped plug must also be exchanged for dampening screw S (order no. 7778 301) (not applicable for types PSV 5(6) S../..-5 or PSV UNF 6 S../..-5, as there is already one there).

PSL 5(6)../..-5

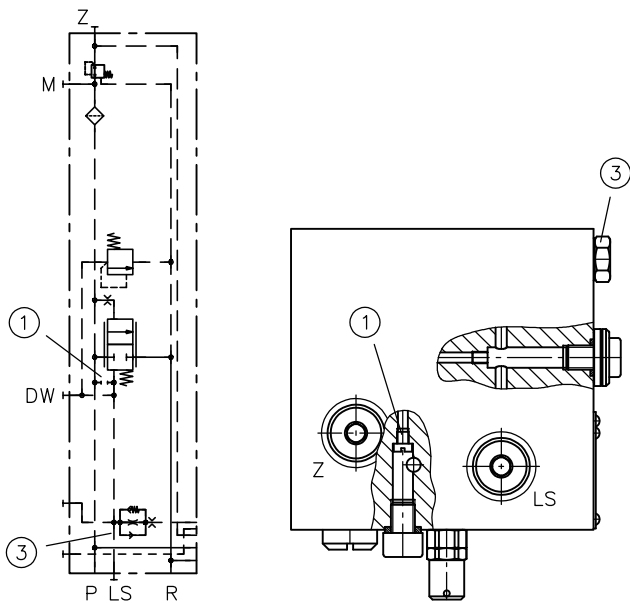

PSV 5(6) S../..-5

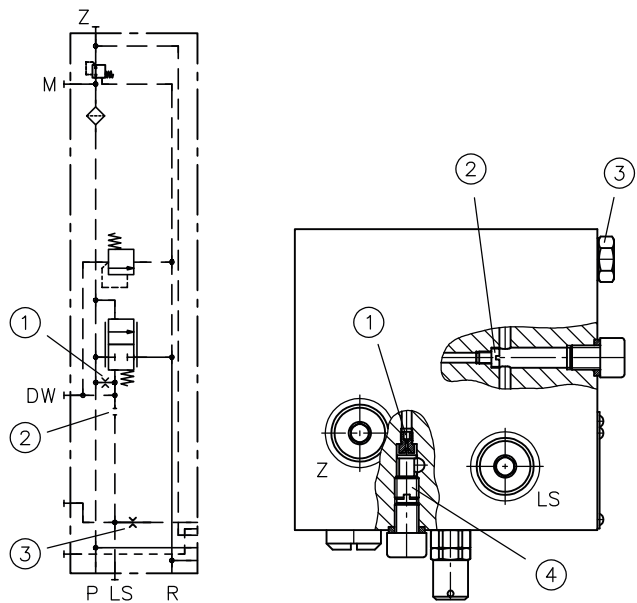

Position	PSL 5(6)../..-5	PSV 5(6) S../..-5
1	Screw 6830 013	Orifice M4x0.6
2	--	Screw 6830 013
3	Dampening screw code S	Dampening screw code B
4	--	Filter screw

5.2.4 Changing the valve spool

The valve spools are not specially adapted to a spool block. This means that spool valves can be exchanged at any time to bring them in line with any changes in consumer requirements.

In doing so, the following must be observed:

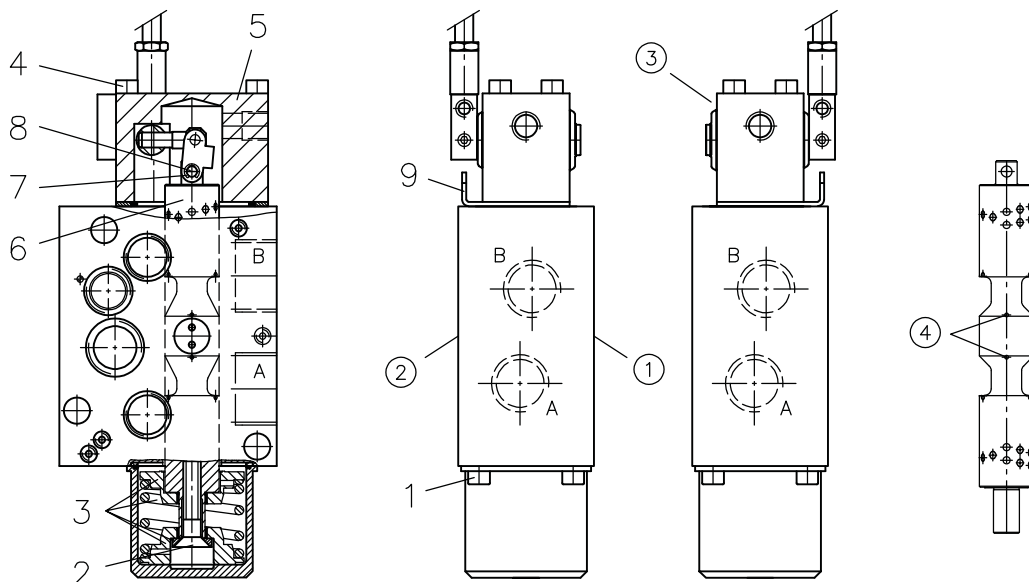

- 1 End plate side
- 2 Connection block side
- 3 Lever housing, turned through 180°
- 4 Metering ports

Changing the valve spool

1. Undo screws **1** (ISO 4762-M5x8-8.8-A2K) and remove spring housing
2. Unscrew screw **2** M8x40
3. Take off spring package with spring plates **3**
4. Undo screws **4** (ISO 4762-M6x60-8.8-A2K)
5. Pull the lever housing out of the spool block together with the valve spool **5 6**
6. Remove lock washer DIN 6799-3.2 and bolt **7 8**
7. Proceed in reverse order to reassemble with (new) valve spool

i INFORMATION

When assembled, the valve spool's metering ports must always face towards the end plate!

Exception: Valve spools with coding 160 do not have metering ports and can be installed any way around.

Turning the lever housing through 180° (reversing the switching direction)

1. As instructed under 1. - 7., but instead of a new valve spool, detach the existing valve spool and re-install it rotated through 180° (see note above).
2. Turn the intermediate sheet **9** through 180° together with the lever housing.
3. All lever housings in the valve bank must be turned.

5.3 Operating instructions

Observe product configuration and pressure/flow rate.

The statements and technical parameters in this document must be strictly observed.
The instructions for the complete technical system must also always be followed.

! NOTICE

- ▶ Read the documentation carefully before usage.
- ▶ The documentation must be accessible to the operating and maintenance staff at all times.
- ▶ Keep documentation up to date after every addition or update.

⚠ CAUTION

Overloading components due to incorrect pressure settings.

Risk of minor injury.

- Pay attention to the maximum operating pressure of the pump, valves and fittings.
- Always monitor the pressure gauge when setting and changing the pressure.

Purity and filtering of the hydraulic fluid

Fine contamination can significantly impair the function of the product. Contamination can cause irreparable damage.

Examples of fine contamination include:

- Swarf
- Rubber particles from hoses and seals
- Dirt due to assembly and maintenance
- Mechanical debris
- Chemical ageing of the hydraulic fluid

! NOTICE

New hydraulic fluid from the manufacturer may not have the required purity.

Damage to the product is possible.

- ▶ Filter new hydraulic fluid to a high quality when filling.
- ▶ Do not mix hydraulic fluids. Always use hydraulic fluid that is from the same manufacturer, of the same type, and with the same viscosity properties.

For smooth operation, pay attention to the cleanliness level of the hydraulic fluid (cleanliness level see Chapter 3, "Parameters").

Additionally applicable document: [D 5488/1 Oil recommendations](#)

5.4 Maintenance information

Check regularly (at least once a year) by visual inspection whether the hydraulic connections are damaged. If external leakages are found, shut down and repair the system.

Clean the surface of the device regularly (at least once a year) (dust deposits and dirt).

6 Other information

6.1 Accessories, spare and individual parts

To purchase spare parts, please see [HAWE Hydraulik interactive contact map](#).

Seal kits

Connection block	DS 7700-51
Valve section	DS 7700-52
Additionally for pneumatic actuation	DS 7700-53

References

Additional versions

- Proportional directional spool valves types PSL, PSV size 2: D 7700-2
- Proportional directional spool valves types PSL/PSV/PSM, size 3: D 7700-3
- Proportional directional spool valve type PSLF, PSVF and SLF: D 7700-F
- Proportional directional spool valve banks type PSLF and PSVF size 7: D 7700-7F
- Directly mounted CAN controls for proportional directional spool valves type PSL and PSV: D 7700 CAN
- Proportional directional spool valve type EDL: D 8086

