

Intermediate plate type NZZ

Product documentation



Hole pattern NG 6

Operating pressure p_{\max} :

500 bar

Flow rate Q_{\max} :

50 l/min



D 7788 Z

08-2023 -1.5 en

HAWE
HYDRAULIK

© by HAWE Hydraulik SE.

The reproduction and distribution of this document, as well as the use and communication of its contents to others without explicit authorization, is prohibited.

Offenders will be held liable for the payment of damages.

All rights reserved in the event of patent or utility model applications.

Brand names, product names and trademarks are not specifically indicated. In particular with regard to registered and protected names and trademarks, usage is subject to legal provisions.

HAWE Hydraulik respects these legal provisions in all cases.

HAWE Hydraulik cannot provide individual guarantees that the stated circuits or procedures (including in part) are not subject to the intellectual property rights of third parties.

Printing date / document generated on: 2023-09-11

Contents

1	Overview of intermediate plate type NZP.....	5
2	Available versions.....	6
2.1	Intermediate plate with throttle valve: NZP 16 Q.....	8
2.2	Intermediate plate with pressure reducing valve: NZP 16 CZ, NZP 16 CZS, NZP 16 ACZ, NZP 16 BCZ.....	10
2.3	Intermediate plate with pressure reducing valve with tracked pressure switch at A: NZP 16 ADK.....	13
2.4	Intermediate plate with pressure reducing valve: NZP 16 LZ, NZP 16 ALZ, NZP 16 BLZ.....	14
2.5	Intermediate plate with switchable pressure reducing valve at P: NZP 16 LZY.....	15
2.6	Intermediate plate with pressure reducing valve: NZP 16 ADM.....	16
2.7	Intermediate plate with proportional pressure reducing valve: NZP 16 PDM.....	17
2.8	Intermediate plate with proportional pressure reducing valve at P: NZP 16 SDM.....	19
2.9	Intermediate plate with randomly connectible 2nd Speed: NZP 16../P., NZP 16T ../T.....	21
2.10	Intermediate plate with check valve with/without inductive position monitoring: NZP 16 SV(S)8..(U).....	24
2.11	Intermediate plate with release valve P → T: NZP 16 BV 1Z, NZP 16 BV 1Y.....	28
2.12	Intermediate plate with short-circuit valve P → A: NZP 16 PBV.....	30
2.13	Intermediate plate with short-circuit valve A → T: NZP 16 ATBV.....	31
2.14	Intermediate plate with check valve at A or B: NZP 16 BV 1A., NZP 16 BV 1B.....	32
2.15	Intermediate plate with 4/4-way directional valve: NZP 16 BV 1A..-B.....	34
2.16	Intermediate plate with short-circuit valve B → A: NZP 16 BV 1S, NZP 16 BV 1R.....	36
2.17	Intermediate plate with release valve A/B → T: NZP 16 BV 1K, NZP 16 BV 1Q.....	37
2.18	Intermediate plate with pendulum valve A → or B → T: NZP 16 BV 1RS, NZP 16 BV 1SR.....	38
2.19	Intermediate plate with quick shut-down valve: SK 7788 590.....	39
2.20	Intermediate plate with releasable check valves at A and B: NZP 16 ADRH.....	40
2.21	Intermediate plate with shock valve: NZP 16 AN.. and others.....	41
2.22	Intermediate plate with load-holding valve: NZP 16 AL, NZP 16 BL.....	43
2.23	Spacer plate.....	45
2.24	Additional element.....	47
3	Parameters.....	49
3.1	General data.....	49
3.2	Weight.....	50
3.3	Characteristic lines.....	51
3.4	Electrical data.....	53

4	Dimensions.....	58
4.1	Intermediate plate with throttle valve: NZP 16 Q.....	58
4.2	Intermediate plate with pressure reducing valve: NZP..CZ.....	59
4.3	Intermediate plate with pressure reducing valve with tracked pressure switch at A: NZP 16 ADK.....	62
4.4	Intermediate plate with pressure reducing valve: NZP 16 LZ, NZP 16 ALZ, NZP 16 BLZ.....	63
4.5	Intermediate plate with switchable pressure reducing valve at P: NZP 16 LZY.....	65
4.6	Intermediate plate with pressure reducing valve: NZP 16 ADM.....	67
4.7	Intermediate plate with proportional pressure reducing valve: NZP 16 PDM.....	68
4.8	Intermediate plate with proportional pressure reducing valve at P: NZP 16 SDM.....	69
4.9	Intermediate plate with randomly connectible 2nd Speed: NZP 16../P., NZP 16T ../T.....	70
4.10	Intermediate plate with check valve with/without inductive position monitoring: NZP 16 SV(S)8..(U).....	72
4.11	Intermediate plate with release valve P → T: NZP 16 BV 1Z, NZP 16 BV 1Y.....	78
4.12	Intermediate plate with short-circuit valve P → A: NZP 16 PBV.....	79
4.13	Intermediate plate with short-circuit valve A → T: NZP 16 ATBV.....	80
4.14	Intermediate plate with check valve at A or B: NZP 16 BV 1A., NZP 16 BV 1B.....	80
4.15	Intermediate plate with 4/4-way directional valve: NZP 16 BV 1A.-B.....	81
4.16	Intermediate plate with short-circuit valve B → A: NZP 16 BV 1S, NZP 16 BV 1R.....	82
4.17	Intermediate plate with release valve A/B → T: NZP 16 BV 1K, NZP 16 BV 1Q.....	83
4.18	Intermediate plate with pendulum valve A → or B → T: NZP 16 BV 1RS, NZP 16 BV 1SR.....	84
4.19	Intermediate plate with quick shut-down valve: SK 7788 590.....	85
4.20	Intermediate plate with releasable check valves at A and B: NZP 16 ADRH.....	86
4.21	Intermediate plate with shock valve: NZP 16 AN.. and others.....	86
4.22	Intermediate plate with load-holding valve: NZP 16 AL, NZP 16 BL.....	89
4.23	Spacer plate.....	90
5	Installation, operation and maintenance information.....	91
5.1	Intended use.....	91
5.2	Assembly information.....	91
5.3	Operating instructions.....	91
5.4	Maintenance information.....	92

1 Overview of intermediate plate type NZP

The intermediate plates can be used to expand the functionality of directional valves with a hole pattern NG 6 according to DIN 24 340-A6.

The intermediate plates type NZP enable additional functions and contain, for example, pressure reducing valves, shock valves, load-holding valves etc. An intermediate plate can be inserted between the sub-plate and the directional valve.

Features and advantages

- Integrated combinations of different functions

Intended applications

- NG 6 valve banks

Versions

- Intermediate plates with throttle valves
- Intermediate plates with pressure reducing valves
- Intermediate plates with shock valves
- Intermediate plates with short-circuit valves
- Intermediate plates with shut-off valves
- Intermediate plates with directional valves
- Intermediate plates with load-holding valves
- Spacer plates

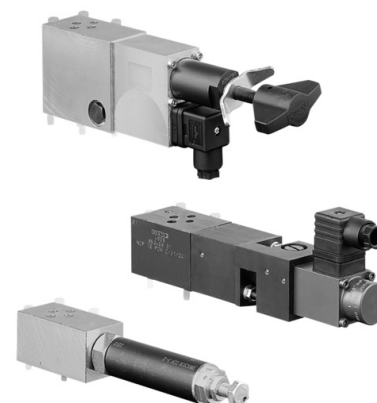

Intermediate plates type NZP

2 Available versions

Ordering examples

NBVP 16 G/B0.8R/ABR2.0 BBR1.5/A3 B9/400/S/NZP 16 Q 22/0

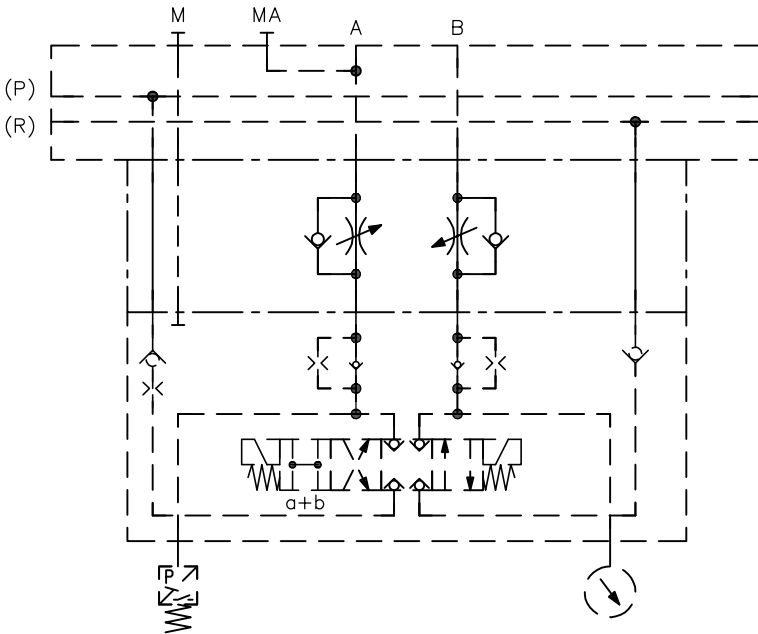

NBVP 16 Z/NZP 16 CZS/01

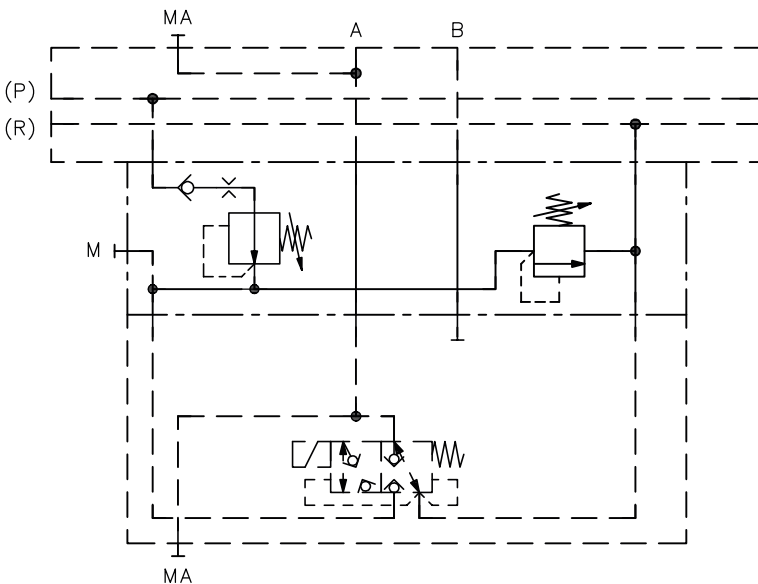

NBVP 16 R/2/NZP 16 BV 1 Y /01

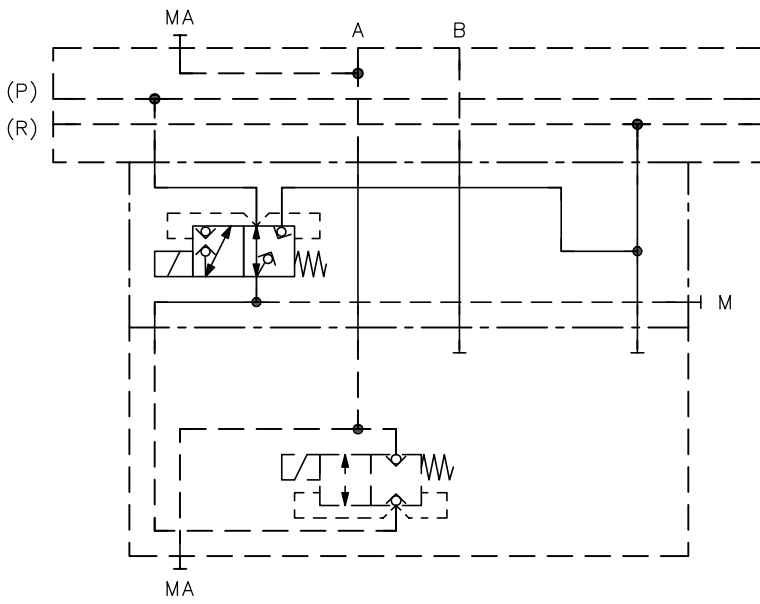

NBVP 16 G/NZP 16 PDM 2-33/0

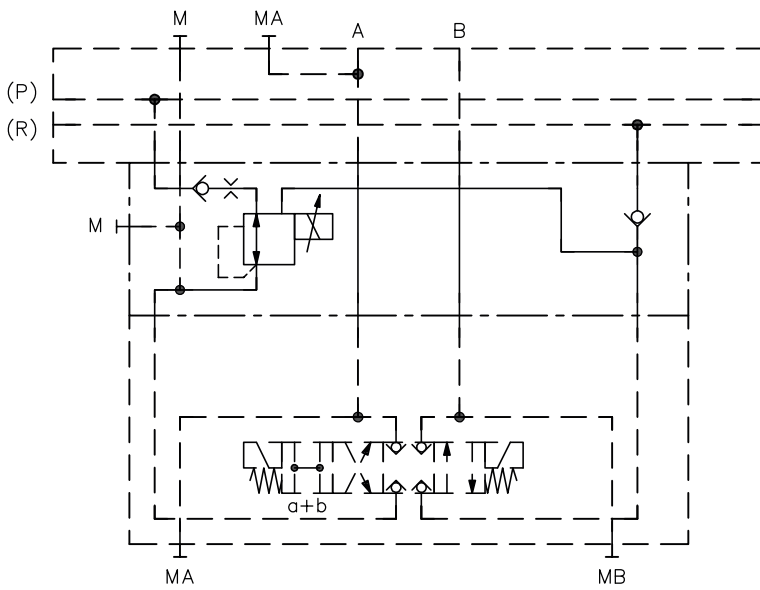

2.1 Intermediate plate with throttle valve: NZP 16 Q

Circuit symbol

NZP 16 Q 22

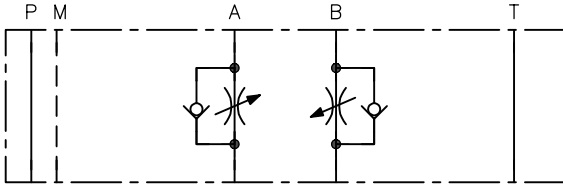

Ordering example

NZP 16 Q 2 2

Throttle and throttle check valve at B [2.1.2 "Throttle version"](#)

Throttle and throttle check valve at A [2.1.2 "Throttle version"](#)

[2.1.1 "Basic type and size"](#)

2.1.1 Basic type and size

Type	Description	Flow rate Q_{\max} (lpm)	Pressure p_{\max} (bar)
NZP 16 Q	Throttle and/or throttle check valve at A and/or B	50	500

Throttles and throttle check valves can be used together in any combination.

Valve used

- Throttle and throttle check valve type CQ, CQR and CQV according to [D 7713](#)

The adjustment can be performed during operation (zero-leakage due to double spindle sealing).







CAUTION

Risk of injury if the device is operated outside the permitted pressure and flow rate ranges.

Risk of minor injury

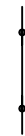
- Observe the permitted pressure and flow rate ranges of the directional valves being used.

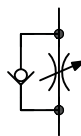
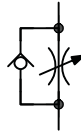
2.1.2 Throttle version

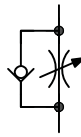
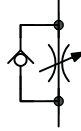
Coding	Designation	Flow rate Q_{max} (lpm)	Circuit symbol
0	Not included, free passage (throttle can be retrofitted)	50	
1	Throttle (type CQ 2)	50	
2	Throttle check valve (P → A(B) free) - Outlet throttle (type CQV 2)	50	
3	Throttle check valve (A(B) → T free) - Inlet throttle (type CQR 2)	50	
4	Throttle with precision control range (type CQ 22)	30	
5	Throttle check valve (P → A(B)) - Outlet throttle with precision control range (type CQV 22)	30	
6	Throttle check valve (A(B) → T free) - Inlet throttle with precision control range (type CQR 22)	30	

2.2 Intermediate plate with pressure reducing valve: NZP 16 CZ, NZP 16 CZS, NZP 16 ACZ, NZP 16 BCZ

Circuit symbol

NZP 16 CZ
NZP 26 CZ

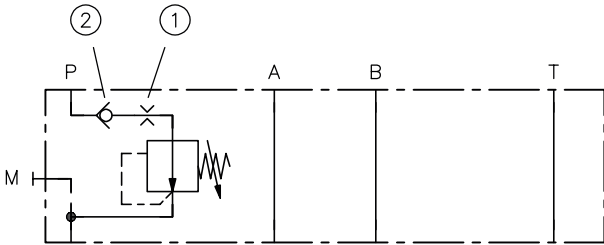

- 1 Orifice at P
- 2 Check valve at P

NZP 16 CZS

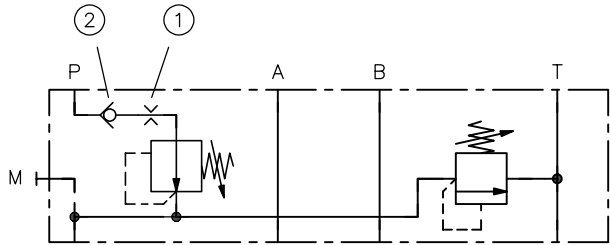

- 1 Orifice at P
- 2 Check valve at P

NZP 16 ACZ

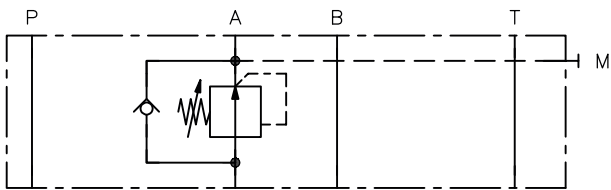

NZP 16 BCZ

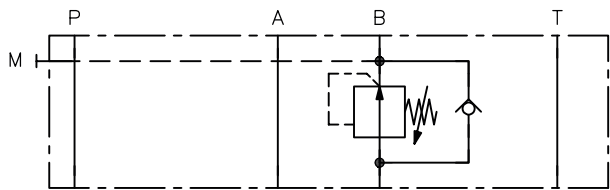

Ordering example

NZP 16 CZ	08R	/400	/B 0,8R
NZP 16 CZS	1	/220	/C 250R

2.24 "Additional element" at P

2.2.3 "Pressure-limiting valve"

Pressure setting

2.2.2 "Pressure reducing valve with adjustment"

2.2.1 "Basic type and size"

2.2.1 Basic type and size

Type	Description	Flow rate Q _{max} (lpm)	Pressure p _{max} (bar)
NZP 16 CZ NZP 26 CZ	Pressure reducing valve at P Difference between NZP 16 and NZP 26: Position of the pressure reducing valve, see Chapter 4, "Dimensions"	22	500
NZP 16 CZS	Pressure reducing valve at P, additional protection of the consumer side with a pressure-limiting valve	22	500
NZP 16 ACZ NZP 16 BCZ	Pressure reducing valve at A or B	22	500

Valve used:

- Pressure reducing valve type CDK according to [D 7745](#)



CAUTION

Risk of injury if the device is operated outside the permitted pressure and flow rate ranges.

Risk of minor injury

- Observe the permitted pressure and flow rate ranges of the directional valves being used.

2.2.2 Pressure reducing valve with adjustment

Coding	Pressure range p _A (bar)	Flow rate Q _{max} (lpm)	Coding	Pressure range p _A (bar)	Flow rate Q _{max} (lpm)
08 *	50 ... 400 (450) **	12	Short model (not for type LZ)		
081 *	50 ... 400 (500) **	12	0.8K	55 ... 310	12
1	30 ... 300	12	1K	30 ... 200	12
11	30 ... 380	12	2K	20 ... 140	12
2	20 ... 200	12	5K	15 ... 90	12
21	20 ... 250	12	21K	18 ... 200	6
5	15 ... 130	12	22K	12 ... 140	6
51	15 ... 165	12	25K	8 ... 90	6
22	12 ... 200	6	208K	30 ... 310	6
25	8 ... 130	6	51K	70 ... 200	22
211	18 ... 380	6	52K	50 ... 140	22
221	12 ... 250	6	55K	30 ... 90	22
251	8 ... 165	6	508K	110 ... 310	22
52	50 ... 200	22			
55	30 ... 130	22			
511	70 ... 380	22			
521	50 ... 250	22			
551	30 ... 165	22			
X	prepared, with tapped plug				

* not for type LZ

** Value in brackets define the pressure stage

Adjustment

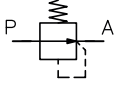
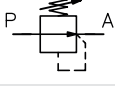
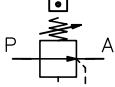
Coding	Description	Circuit symbol
Without coding	Fixed, tool adjustable	
R	Manually adjustable, with lock nut not directly combinable next to each other	
H	Turn knob, lockable	

2.2.3 Pressure-limiting valve

Coding	Pressure range (bar)
B	100 ... 500
C	65 ... 315
E	30 ... 160
F	20 ... 80

2.3 Intermediate plate with pressure reducing valve with tracked pressure switch at A: NZP 16 ADK

Circuit symbol

NZP 16 ADK

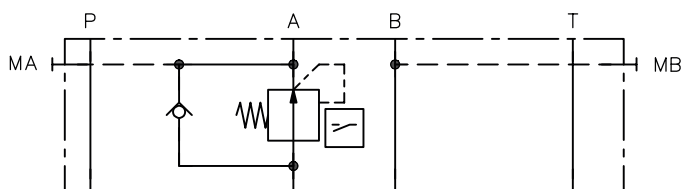

Ordering example

NZP 16 ADK	08R	/400	/B 0,8R	-M
				2.3.2 "Line connector version"
				2.24 "Additional element" at P
				Pressure setting
				2.2.2 "Pressure reducing valve with adjustment"
				2.3.1 "Basic type and size"

2.3.1 Basic type and size

Type	Description	Flow rate Q _{max} (lpm)	Pressure p _{max} (bar)
NZP 16 ADK	Pressure reducing valve with tracked pressure switch at A	22	500

Valve used:

- Functional parts of pressure reducing valve type DK according to D 7941



CAUTION

Risk of injury if the device is operated outside the permitted pressure and flow rate ranges.

Risk of minor injury

- Observe the permitted pressure and flow rate ranges of the directional valves being used.

2.3.2 Line connector version

Coding	Description	Version
X	Without line connector	Line connector EN 175 301-803
G	With line connector	
L	With line connector with LED	
L5K L10K	With line connector with LED and 5 or 10 m cable	
M	With LED and connection thread M12x1 (in compliance with DESINA)	

2.4 Intermediate plate with pressure reducing valve: NZP 16 LZ, NZP 16 ALZ, NZP 16 BLZ

Circuit symbol

NZP 16 LZ

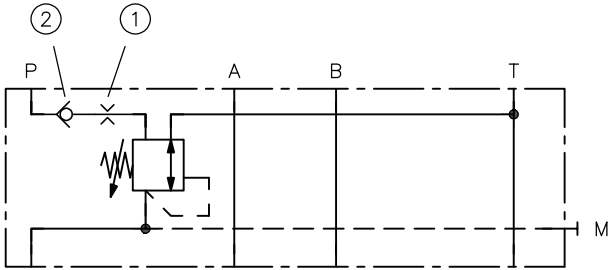

- 1 Orifice at P
- 2 Check valve at P

NZP 16 ALZ

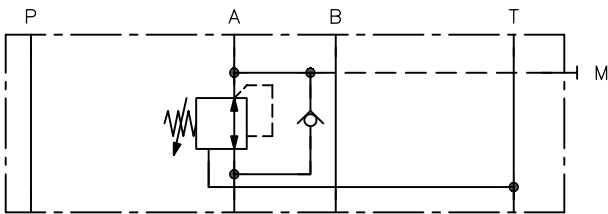

NZP 16 BLZ

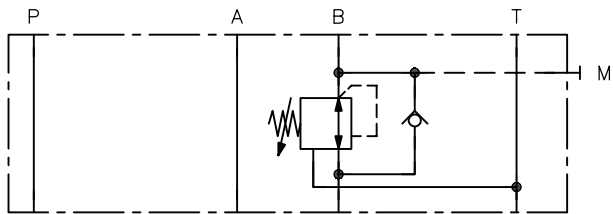

Ordering example

NZP 16 LZ 1R /300 /B 0,8R

2.24 "Additional element" at P

Pressure setting

2.2.2 "Pressure reducing valve with adjustment"

2.4.1 "Basic type and size"

2.4.1 Basic type and size

Type	Description	Flow rate Q_{max} (lpm)	Pressure p_{max} (bar)
NZP 16 LZ	Pressure reducing valve with overpressure function at P	22	500
NZP 16 ALZ	Pressure reducing valve with overpressure function at A	22	500
NZP 16 BLZ	Pressure reducing valve with overpressure function at B	22	500

Valve used:

- Pressure reducing valve, type CLK according to D 7745 L

⚠ CAUTION

Risk of injury if the device is operated outside the permitted pressure and flow rate ranges.

Risk of minor injury

- Observe the permitted pressure and flow rate ranges of the directional valves being used.

2.5 Intermediate plate with switchable pressure reducing valve at P: NZP 16 LZY

Circuit symbol

NZP 16 LZY

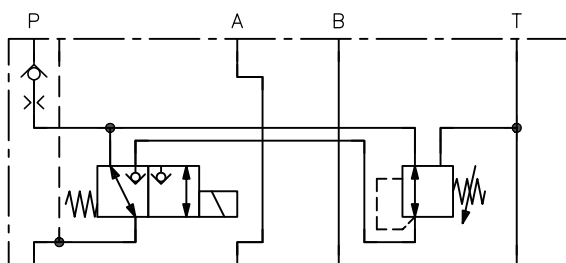

Ordering example

NZP 16 LZY 1R /280 /B 0,8R -X 24

2.11.2 "Solenoid voltage and connector"

2.24 "Additional element" at P

Pressure setting

2.2.2 "Pressure reducing valve with adjustment"

2.5.1 "Basic type and size"

2.5.1 Basic type and size

Type	Description	Flow rate Q_{\max} (lpm)	Pressure p_{\max} (bar)
NZP 16 LZY	Connectible pressure reducing valve with overpressure function at P	22	500

Valve used:

- Pressure reducing valve, type CLK according to D 7745 L
- Functional parts of the directional seated valve of BVP 1 Z according to D 7765

CAUTION

Risk of injury if the device is operated outside the permitted pressure and flow rate ranges.

Risk of minor injury

- Observe the permitted pressure and flow rate ranges of the directional valves being used.

2.6 Intermediate plate with pressure reducing valve: NZP 16 ADM

Circuit symbol

NZP 16 ADM 2

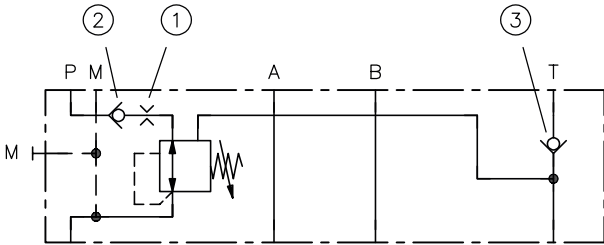

- 1 Orifice at P
- 2 Check valve at P
- 3 Return pressure stop

Ordering example

NZP 16 ADM 2	AR	/..	/B 0,8R	S
2.6.1 "Basic type and size"				
2.6.2 "Pressure-limiting valve"				
Pressure setting				
2.24 "Additional element" at P				
2.24 "Additional element" at T				

2.6.1 Basic type and size

Type	Description	Flow rate Q_{max} (lpm)	Pressure p_{max} (bar)	Pressure p_{max} A, B (bar)
NZP 16 ADM 2	Pressure reducing valve at P	25	315	250

Valve used:

- Functional parts of pressure reducing valve type ADM 2.. according to D 7120



CAUTION

Risk of injury if the device is operated outside the permitted pressure and flow rate ranges.

Risk of minor injury

- Observe the permitted pressure and flow rate ranges of the directional valves being used.

2.6.2 Pressure-limiting valve

Coding	Pressure range (bar)
A	160 ... 250
C	45 ... 160
D	30 ... 120
F	6 ¹ ... 55

- 1 Pressure can only be set to max. 10 lpm.

2.7 Intermediate plate with proportional pressure reducing valve: NZP 16 PDM

Circuit symbol

NZP 16 PDM 2

(detailed)

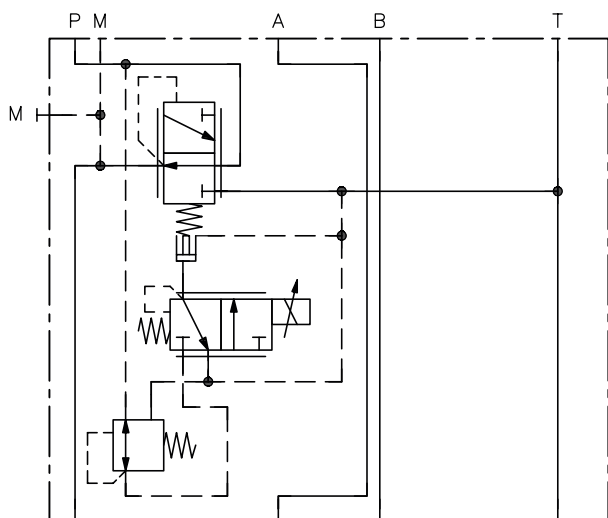

NZP 16 PDM 2

(simplified)

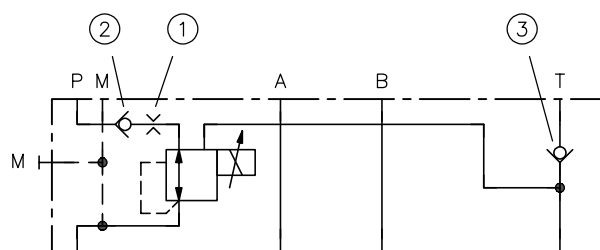

- 1 Orifice
- 2 Check valve
- 3 Return pressure stop

Ordering example

NZP 16 PDM 2	-41	/X 12	/B 0,8R	S
				2.24 "Additional element" at T
				2.24 "Additional element" at P
				2.7.3 "Solenoid voltage proportional valve"
				2.7.2 "Pressure range"
				2.7.1 "Basic type and size"

2.7.1 Basic type and size

Type	Description	Flow rate Q_{\max} (lpm)	Pressure p_{\max} (bar)
NZP 16 PDM 2	Proportional pressure-reducing valve at P	25	450

Valve used:

- Functional parts of proportional pressure-reducing valve type PDM 2.. according to [D 7584/1](#)

CAUTION

Risk of injury if the device is operated outside the permitted pressure and flow rate ranges.

Risk of minor injury

- Observe the permitted pressure and flow rate ranges of the directional valves being used.

2.7.2 Pressure range

Coding	Pressure range (bar)
-31	5 ... 110
-32	5 ... 180
-33	6 ... 280
-34	7 ... 350
-35	10 ... 450
-41	5 ... 45
-42	5 ... 70
-43	5 ... 110
-44	5 ... 180

2.7.3 Solenoid voltage proportional valve

Coding	Electrical connection	Nominal voltage	Protection class * (EN 60529)
X 12 X 24	EN 175 301-803 A ▪ G with line connector (e.g. G 24)	12 V DC 24 V DC	IP 65

* For correctly installed line connector

Electrical connection for actuating solenoid

NZP 16 PDM 2-3
EN 175 301-803 A

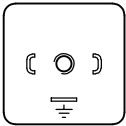

NZP 16 PDM 2-4
Industry standard contact gap 11 mm



NZP 16 SDM 2
EN 175 301-803 A

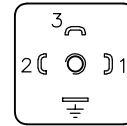

1 – 3 proportional pressure reducing valve
1 – 2 directional seated valve (on/off)

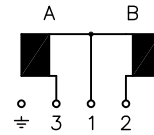

2.8 Intermediate plate with proportional pressure reducing valve at P: NZP 16 SDM

Circuit symbol

NZP 16 SDM 2
(detailed)

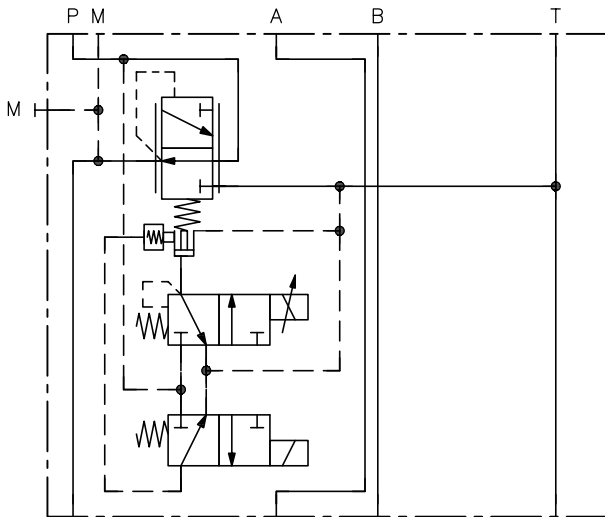

NZP 16 SDM 2
(simplified)

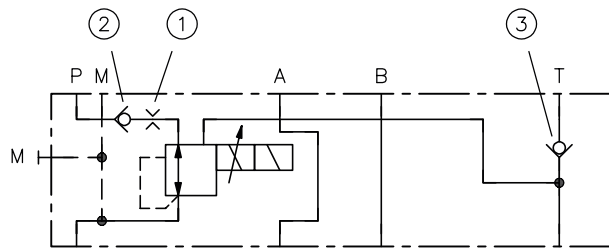

- 1 Orifice
- 2 Check valve
- 3 Return pressure stop

Ordering example

NZP 16 SDM 2	B	/X 24	/B 0,8R	S
				2.24 "Additional element" at T
				2.24 "Additional element" at P
				2.7.3 "Solenoid voltage proportional valve"
				2.8.2 "pressure ranges"
				2.8.1 "Basic type and size"

2.8.1 Basic type and size

Type	Description	Flow rate Q _{max} (lpm)	Pressure p _{max} (bar)	Pressure p _{max} A,B (bar)
NZP 16 SDM 2	Proportional pressure-reducing valve at P	25	150	125

Valve used:

- Functional parts of proportional pressure-reducing valve type PDM 2.. according to [D 7584/1](#)

As well as the proportional pressure reducing function, the set piston has a mechanical clamp. This is activated by switching off the magnet (1-2).

The setting of the operating pressure is maintained until the magnet (1-2) is energised and a proportional pressure adjustment (1-3) takes place.

It is possible to monitor the set pressure via a pressure gauge at port M.



CAUTION

Risk of injury if the device is operated outside the permitted pressure and flow rate ranges.

Risk of minor injury

- Observe the permitted pressure and flow rate ranges of the directional valves being used.

2.8.2 pressure ranges

Coding	Pressure range (bar)	Min. required pump pressure (bar)
A	6 ... 60	65
B	9 ... 92	80
G	8 ... 80	80
E	12 ... 125	80

2.9 Intermediate plate with randomly connectible 2nd Speed: NZP 16../P.., NZP 16T ../T..

Circuit symbol

NZP 16 V/P..
NZP 16 VPG/P..

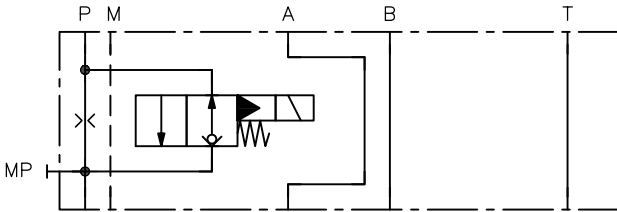

NZP 16 S/P..
NZP 16 SPG/P..

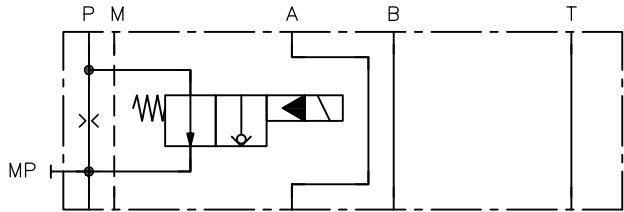

NZP 16 X/P..

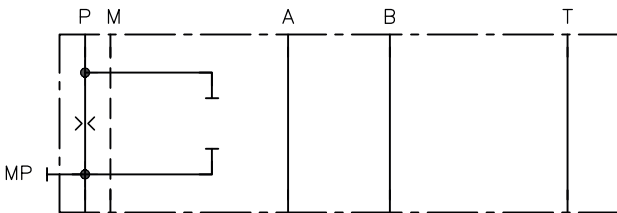

NZP 16 VP/P..

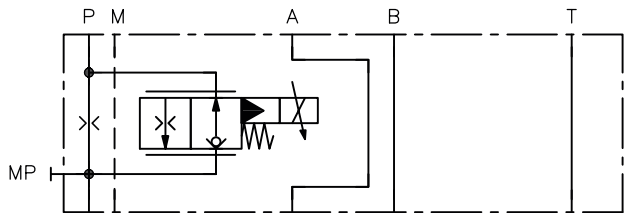

NZP 16 SP/P..

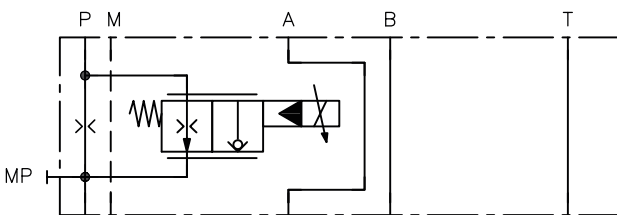

NZP 16 TX/T..

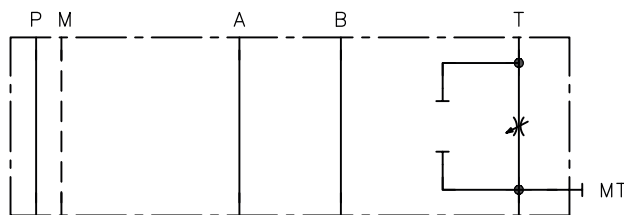

NZP 16 TS/T..
NZP 16 TSPG/T..

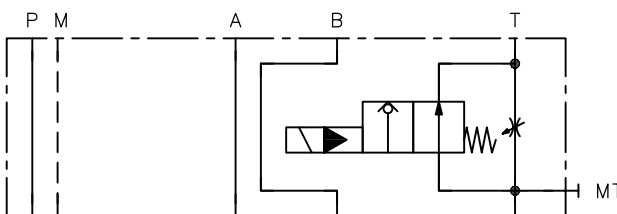

NZP 16 TV/T..
NZP 16 TVPG/T..

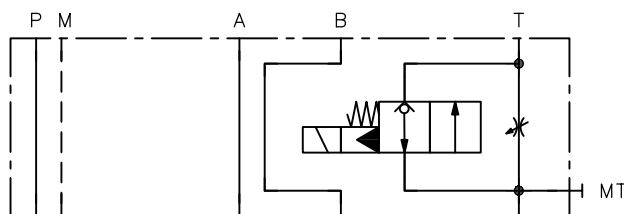

NZP 16 TVP/T..

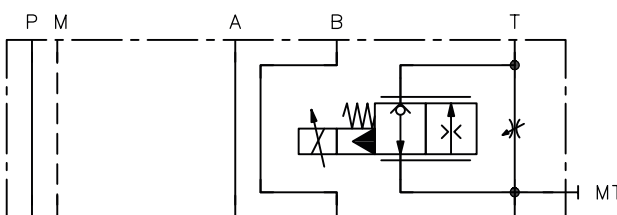

NZP 16 TSP/T..

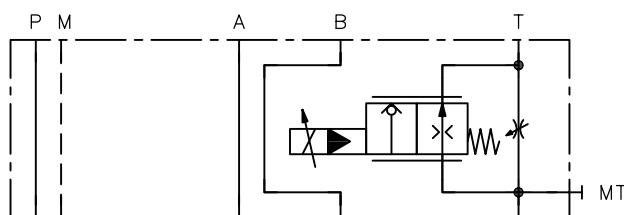

Ordering example

NZP 16	V	/P	B 1.0	-X 24
NZP 16T	VP	/T	CQ 22	-WG 230

2.9.4 "Solenoid voltage and connector"
 2.9.3 "Orifices and throttles"
 2.9.1 "Basic type and size"
 2.9.2 "Connectible directional valve"
 2.9.1 "Basic type and size"

2.9.1 Basic type and size

Type	Description	Flow rate Q _{max} (lpm)	Pressure p _{max} (bar)
NZP 16 ../P..	Valves at P	40	400
NZP 16T ../T..	Valves at T	40	400

CAUTION

Risk of injury and possible material damage if operated outside the permitted pressure and flow rate ranges.

- Observe the permitted pressure and flow rate ranges of the directional valves being used.
- Type NZP 16 T../T.. : Observe the permissible return pressure of the directional valve being used.

2.9.2 Connectible directional valve

Coding	Description	Type
V	N/C contact – on/off	EM 21 V
S	N/O contact – on/off	EM 21 S
VP	N/C contact – proportional throttle	EMP 21 V
SP	N/O contact – proportional throttle	EMP 21 S
VPG	N/C contact – damped	EMP 21 VG
SPG	N/O contact – damped	EMP 21 SG
X	Without directional valve, hole blocked	

Valve used:

- Directional seated valve type EM 21 and EMP 21 according to D 7490/1

2.9.3 Orifices and throttles

Coding	Comment	Circuit symbol
without	without orifice, hole sealed	
B 0,4 B 0,5 B 0,8 B 1,0 B 1,5 B 1,8 B 2,0 B 2,5	Orifice with orifice diameter in mm screwed in at P or T channel	
CQ 2	Throttle, adjustable (type CQ 2 according to D 7713)	
CQ 22	Throttle with precision control range, adjustable (type CQ 22 according to D 7713)	
without	For proportional throttles coding VP and SP	

2.9.4 Solenoid voltage and connector

Coding	Electrical connection	Nominal voltage	Protection class * (EN 60529)	NZP 16.V NZP 16.S	NZP 16.VP NZP 16.SP NZP 16.VPG NZP 16.SPG
X 12 X 24 X 98 X 205 WG 110 WG 230	EN 175 301-803 A <ul style="list-style-type: none"> ▪ G with line connector (e.g. G 24) ▪ L with LED in line connector (e.g. L 24) ▪ WG with alternating rectifier in line connector 	12 V DC 24 V DC 98 V DC 205 V DC 110 V AC 50/60 Hz 230 V AC 50/60 Hz	IP 65	● ● ● ● ●	● ● ● ● ●
M 24	M12x1	24 V DC	IP 67		●

* For correctly installed line connector

Electrical connection for actuating solenoid

G.., X.., L.., WG..

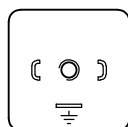

M..

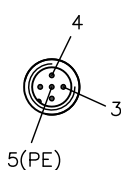

**2.10 Intermediate plate with check valve with/without inductive position monitoring:
NZP 16 SV(S)8..(U)**

Circuit symbol

i INFORMATION

Pump side at top, consumer side at bottom, display of all circuit symbols in version NZP 16 SV8 R/..

NZP 16 SV../A

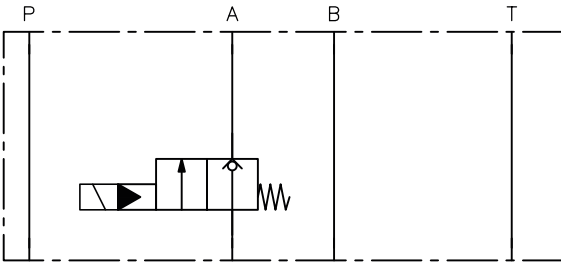

NZP 16 SV../A1

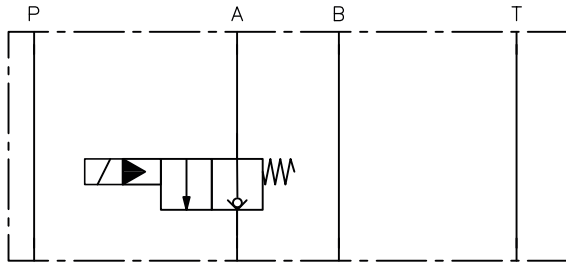

NZP 16 SV../B

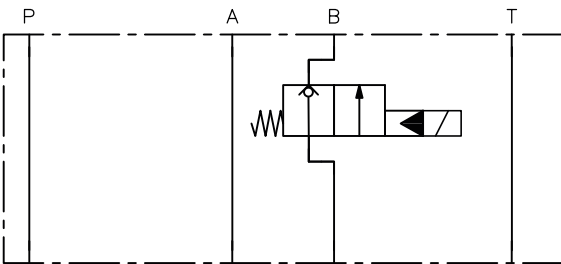

NZP 16 SV../B1

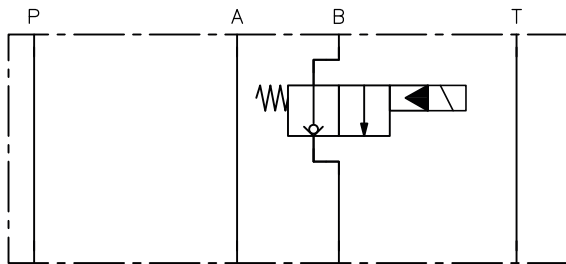

NZP 16 SV../AB

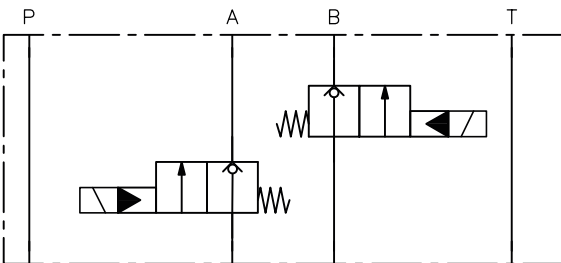

NZP 16 SV../AB1

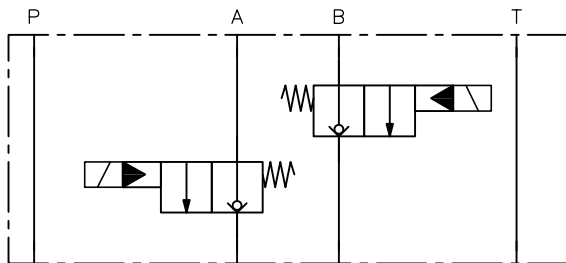

NZP 16 SV../PB..

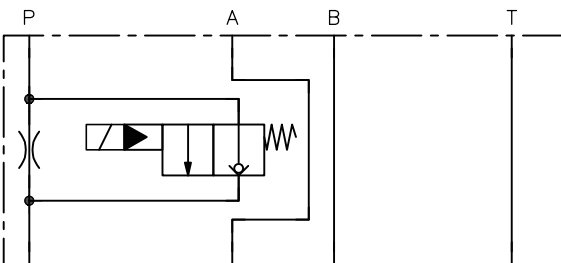

NZP 16 SV../TB..

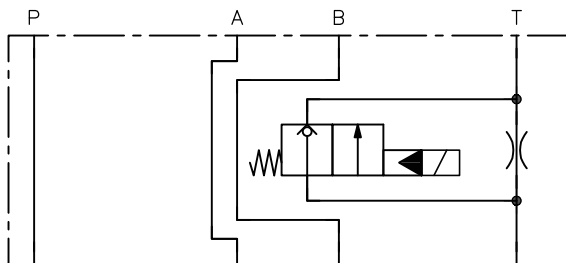

NZP 16 SV../ATBT..

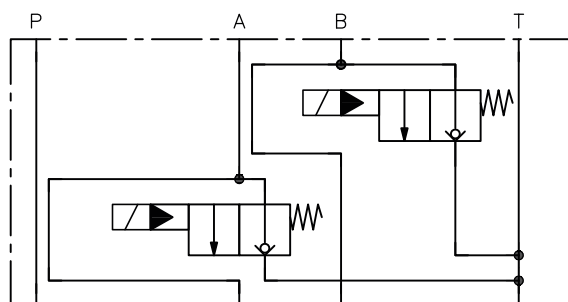

NZP 16 SV8 X/A..

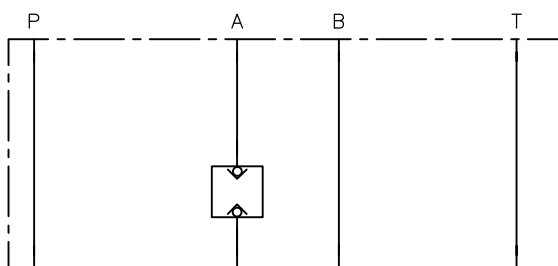

i INFORMATION

Versions with tapped plug in the case of the following types:

- NZP 16 SV8 X/A
- NZP 16 SV8 X/B
- NZP 16 SV8 X/AB
- NZP 16 SV8 X/P
- NZP 16 SV8 X/T

Ordering example

NZP 16 SV8	R	/P	B 0,4	-X 24
NZP 16 SVS8	R	/A		-WG 115

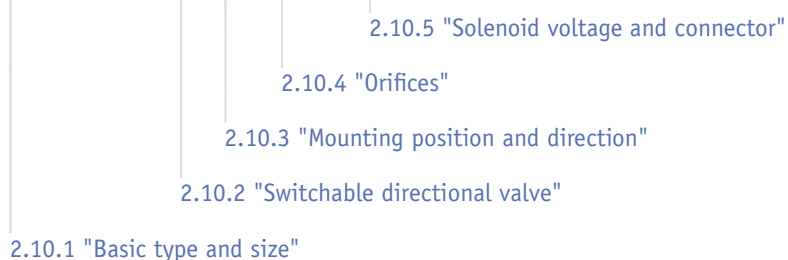

2.10.1 Basic type and size

Type	Description	Flow rate Q _{max} (l/min)	Pressure p _{max} (bar)
NZP 16 SV8	Directional valve type SVNE 8	30	350
NZP 16 SVS8	Directional valve type SVSE 8 optimised switching time version		

⚠ CAUTION

Risk of injury and possible material damage if operated outside the permitted pressure and flow rate ranges.

- Observe the permitted pressure and flow rate ranges of the directional valves being used.
- Type NZP 16 SV.8../T: observe the permissible return pressure of the directional valve being used.

2.10.2 Switchable directional valve

Coding	Description	Type	Circuit symbol
R	N/C contact	SVNE 8 R, SVSE 8 R	
S	N/O contact	SVNE 8 S	
R2	N/C contact with bi-directional flow in switching position	SVNE 8 R2, SVSE 8 R2	
S2	N/O contact with bi-directional flow in 0 position	SVNE 8 S2	
RU	N/C contact with inductive position monitoring	SVNE 8 RU	
SU	N/O contact with inductive position monitoring	SVNE 8 SU	
R2U	N/C contact with bi-directional flow in switching position with inductive position monitoring	SVNE 8 R2U	
S2U	N/O contact with bi-directional flow in 0 position with inductive position monitoring	SVNE 8 S2U	
X	Sealed with blind plug, NZP 16 SV8 X/.. only	Tapped plug	

i INFORMATION

For the valves used and other technical data, see [D 6354/1](#)

2.10.3 Mounting position and direction



Coding	Description
A	Valve in A channel, consumer blocked
A1	Valve in A channel, locking direction towards consumer
B	Valve in B channel, consumer blocked
B1	Valve in B channel, locking direction towards consumer
AB	Valve in A and B channel, consumer blocked
AB1	Valve in A and B channel, locking direction towards consumer
P	Valve in P channel, locking direction towards consumer
T	Valve in T channel, locking direction towards tank
ATBT	Valve in A and B channel, with relief towards tank

NOTICE

For the mounting direction with the number **1**, the corresponding intermediate plate must be rotated 180°.
For the mounting direction or position **T**, the intermediate plate for the mounting direction or position **P** must be rotated 180°.

2.10.4 Orifices

Only possible on variants with coding **P** and **T**.

Coding	Comment	Circuit symbol
B 0	Hole sealed (orifice B0 glued in place, cannot be exchanged) not available with directional valve X (blind plug)	
B 0.4 B 0.5 B 0.8 B 1.0 B 1.5 B 1.8 B 2.0 B 2.5	Orifice with orifice diameter in mm screwed in at P or T channel	

2.10.5 Solenoid voltage and connector

Coding	Electrical connection	Nominal voltage	Protection class * (IEC 60529)	SV.E 8	SVNE 8 .(.)U
X 12	EN 175 301-803 A	12 V DC	IP 65	●	●
X 24	■ G with line connector (e.g. G 24)	24 V DC		●	●
X 102	■ L with LED in line connector (e.g. L 24)	102 V DC		●	
X 205		205 V DC		●	
WG 115	■ WG with alternating rectifier in the line connector	115 V AC 50/60 Hz		●	
WG 230		230 V AC 50/60 Hz	●		

* For correctly installed line connector

Electrical connection for actuating solenoid

G., X., L., WG..

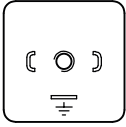

2.11 Intermediate plate with release valve P → T: NZP 16 BV 1Z, NZP 16 BV 1Y

Circuit symbol

NZP 16 BV 1Z

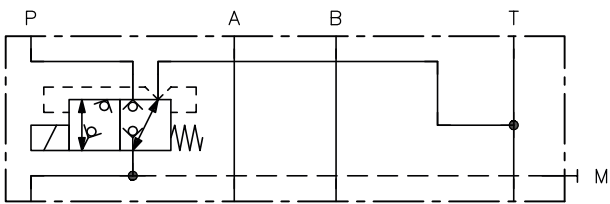

NZP 16 BV 1Y

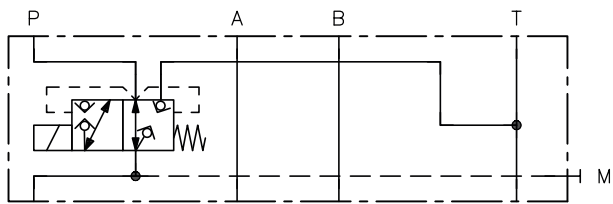

Ordering example

NZP 16 BV 1 Z	/R	S	-X 24
			2.11.2 "Solenoid voltage and connector"
			2.24 "Additional element" at T
			2.24 "Additional element" at P
			2.11.1 "Basic type and size"

2.11.1 Basic type and size

Type	Description	Flow rate Q _{max} (lpm)	Pressure p _{max} (bar)
NZP 16 BV 1Z	Release P → T (de-energised)	20	400
NZP 16 BV 1Y	Release P → T (energised)	20	400



CAUTION

Risk of injury if the device is operated outside the permitted pressure and flow rate ranges.

Risk of minor injury

- Observe the permitted pressure and flow rate ranges of the directional valves being used.

2.11.2 Solenoid voltage and connector

Coding	Electrical connection	Nominal voltage	Protection class * (IEC 529)	Pressure p _{max} (bar)
X 12 X 24 X 98 X 205 WG 110 WG 230	EN 175 301-803 A <ul style="list-style-type: none"> ▪ G with line connector (e.g. G 24) ▪ L with LEDs in line connector (e.g. L 24) ▪ WG with alternating rectifier in line connector 	12 V DC 24 V DC 98 V DC 205 V DC 110 V AC 50/60 Hz 230 V AC 50/60 Hz	IP 65	400
XM 12 XM 24 XM 98 XM 205 WGM 110 WGM 230		12 V DC 24 V DC 98 V DC 205 V DC 110 V AC 50/60 Hz 230 V AC 50/60 Hz		
M 24/8W	M12x1	24 V DC		250
H 1/4	Hydraulic	Pilot pressure: p _{control} = 24 – 400 bar		400

* For correctly installed line connector

Electrical connection for actuating solenoid

G., X., L., WG..

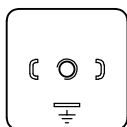

M..

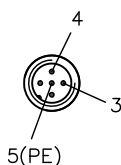

2.12 Intermediate plate with short-circuit valve P → A: NZP 16 PBV

Circuit symbol

NZP 16 PBV 1S

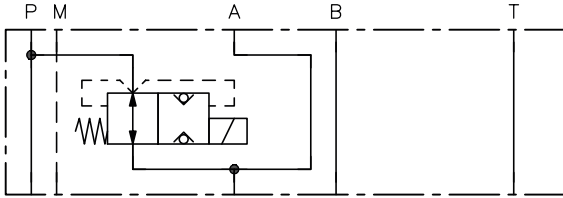

NZP 16 PBV 1R

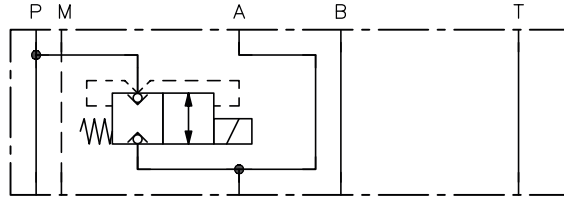

Ordering example

NZP 16 PBV 1S -X 24

2.11.2 "Solenoid voltage and connector", also pneumatically actuated with coding P

2.12.1 "Basic type and size"

2.12.1 Basic type and size

Type	Description	Flow rate Q _{max} (lpm)	Pressure p _{max} (bar)
NZP 16 PBV 1S	Short-circuit valve P → A NO contact	20	400
NZP 16 PBV 1R	Short-circuit valve P → A N/C contact	20	400



CAUTION

Risk of injury if the device is operated outside the permitted pressure and flow rate ranges.

Risk of minor injury

- Observe the permitted pressure and flow rate ranges of the directional valves being used.

2.13 Intermediate plate with short-circuit valve A → T: NZP 16 ATBV

Circuit symbol

NZP 16 ATBV 1S

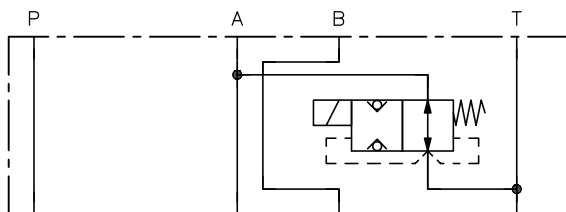

NZP 16 ATBV 1R

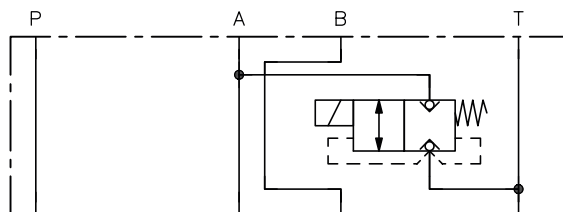

Ordering example

NZP 16 ATBV 1S	R	S1	-X 24
			2.11.2 "Solenoid voltage and connector"
			2.24 "Additional element" at T
			2.24 "Additional element" at P
2.13.1 "Basic type and size"			

2.13.1 Basic type and size

Type	Description	Flow rate Q_{\max} (lpm)	Pressure p_{\max} (bar)
NZP 16 ATBV 1S	Short-circuit valve A → T NO contact	20	500
NZP 16 ATBV 1R	Short-circuit valve A → T N/C contact	20	500

Valve used:

- Directional seated valve type BVE1 according to D 7921



CAUTION

Risk of injury if the device is operated outside the permitted pressure and flow rate ranges.

Risk of minor injury

- Observe the permitted pressure and flow rate ranges of the directional valves being used.

2.14 Intermediate plate with check valve at A or B: NZP 16 BV 1A.., NZP 16 BV 1B..

Circuit symbol

NZP 16 BV 1AS

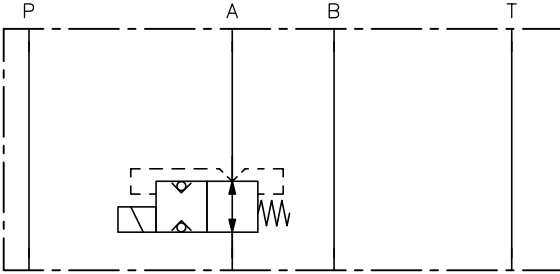

NZP 16 BV 1AR

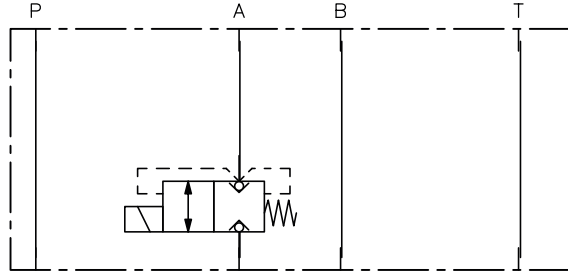

NZP 16 BV 1BS

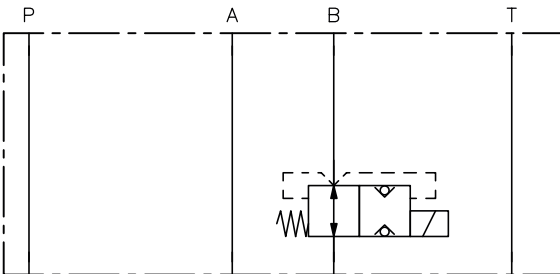

NZP 16 BV 1BR

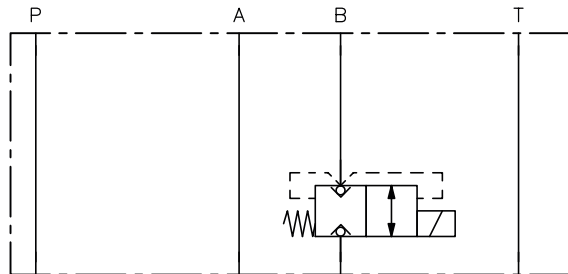

Ordering example

NZP 16 BV 1AS	/R	/AB0,7 BB0,6	/S	-X 24
			2.11.2 "Solenoid voltage and connector"	
			2.24 "Additional element" at T	
		2.24 "Additional element" at A and/or B		
	2.24 "Additional element" at P			
2.14.1 "Basic type and size"				

2.14.1 Basic type and size

Type	Description	Flow rate Q _{max} (lpm)	Pressure p _{max} (bar)
NZP 16 BV 1AS	Check valve at A NO contact	20	400
NZP 16 BV 1AR	Check valve at A N/C contact	20	400
NZP 16 BV 1BS	Check valve at B NO contact	20	400
NZP 16 BV 1BR	Check valve at B N/C contact	20	400



CAUTION

Risk of injury if the device is operated outside the permitted pressure and flow rate ranges.

Risk of minor injury

- Observe the permitted pressure and flow rate ranges of the directional valves being used.

2.15 Intermediate plate with 4/4-way directional valve: NZP 16 BV 1A..-B..

Circuit symbol

NZP 16 BV 1AS-BS

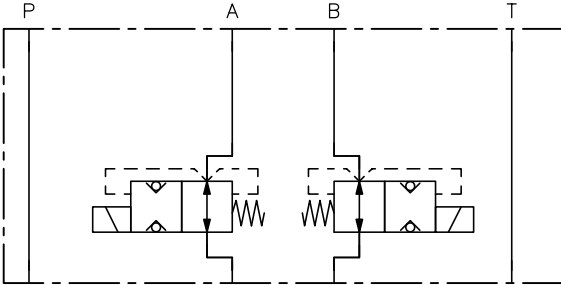

NZP 16 BV 1AR-BR

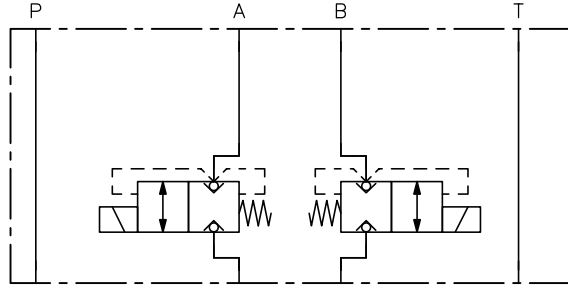

NZP 16 BV 1AR-BS

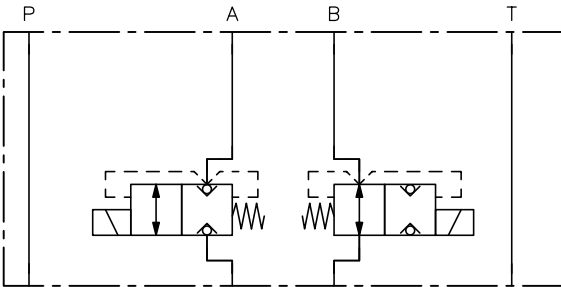

NZP 16 BV 1AS-BR

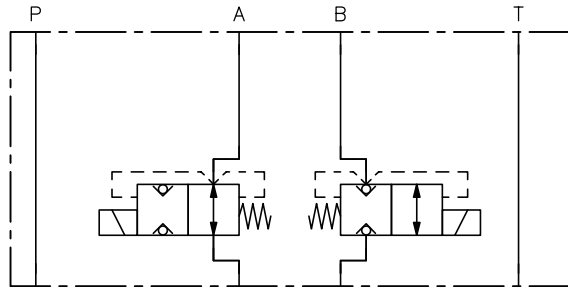

Ordering example

NZP 16 BV 1AR-BR	/R	/AB0,7 BB0,6	/S	-X 24
				2.11.2 "Solenoid voltage and connector"
				2.24 "Additional element" at T
				2.24 "Additional element" at A and/or B
				2.24 "Additional element" at P
				2.15.1 "Basic type and size"

2.15.1 Basic type and size

Type	Description	Flow rate Q _{max} (lpm)	Pressure p _{max} (bar)
NZP 16 BV 1AS-BS	De-energised, A and B open	20	400
NZP 16 BV 1AR-BR	De-energised, A and B closed	20	400
NZP 16 BV 1AR-BS	De-energised, A closed, B open	20	400
NZP 16 BV 1AS-BR	De-energised, A open, B closed	20	400



CAUTION

Risk of injury if the device is operated outside the permitted pressure and flow rate ranges.

Risk of minor injury

- Observe the permitted pressure and flow rate ranges of the directional valves being used.

2.16 Intermediate plate with short-circuit valve B → A: NZP 16 BV 1S, NZP 16 BV 1R

Circuit symbol

NZP 16 BV 1S
NZP 26 BV 1S

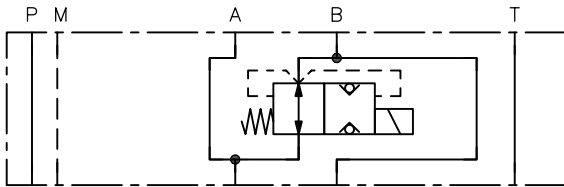

NZP 16 BV 1R
NZP 26 BV 1R

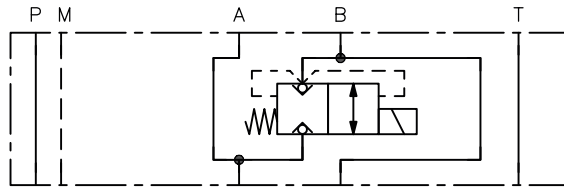

Ordering example

NZP 16 BV 1S -X 24
NZP 26 BV 1R -WG 230

2.11.2 "Solenoid voltage and connector"

2.16.1 "Basic type and size"

2.16.1 Basic type and size

Type	Description	Flow rate Q _{max} (lpm)	Pressure p _{max} (bar)
NZP 16 BV 1S NZP 26 BV 1S	Short-circuit valve B → A NO contact Difference between NZP 16 and NZP 26: Position of the pressure reducing valve see Chapter 4, "Dimensions"	20	400
NZP 16 BV 1R NZP 26 BV 1R	Short-circuit valve B → A N/C contact Difference between NZP 16 and NZP 26: Position of the pressure reducing valve see Chapter 4, "Dimensions"	20	400



CAUTION

Risk of injury if the device is operated outside the permitted pressure and flow rate ranges.

Risk of minor injury

- Observe the permitted pressure and flow rate ranges of the directional valves being used.

2.17 Intermediate plate with release valve A/B → T: NZP 16 BV 1K, NZP 16 BV 1Q

Circuit symbol

NZP 16 BV 1K

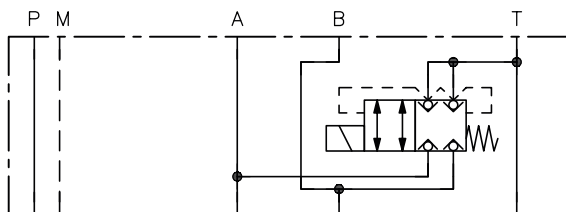

NZP 16 BV 1Q

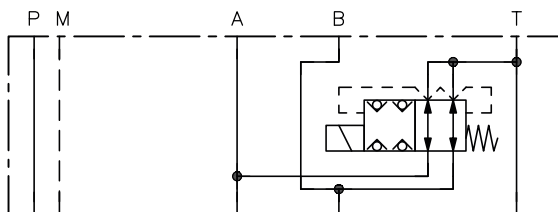

Ordering example

NZP 16 BV 1K	-X 24
NZP 16 BV 1Q	-WGM 230

2.11.2 "Solenoid voltage and connector"

2.17.1 "Basic type and size"

2.17.1 Basic type and size

Type	Description	Flow rate Q_{max} (lpm)	Pressure p_{max} (bar)
NZP 16 BV 1K	Release valve Neutral position: A/B → T Closed	20	400
NZP 16 BV 1Q	Release valve Neutral position: A/B → T Open	20	400

CAUTION

Risk of injury if the device is operated outside the permitted pressure and flow rate ranges.

Risk of minor injury

- Observe the permitted pressure and flow rate ranges of the directional valves being used.

2.18 Intermediate plate with pendulum valve A → or B → T: NZP 16 BV 1RS, NZP 16 BV 1SR

Circuit symbol

NZP 16 BV 1RS

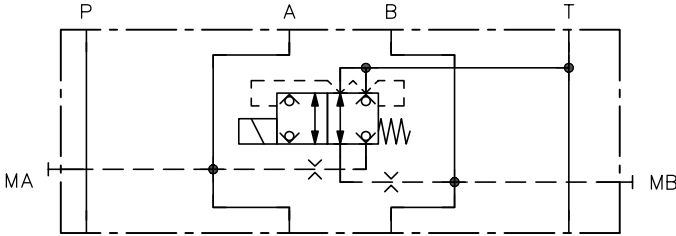

NZP 16 BV 1SR

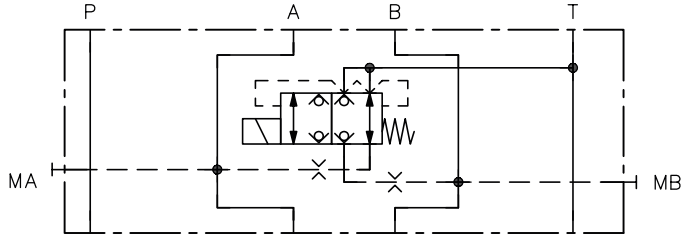

Ordering example

NZP 16 BV 1RS	-X 24
NZP 16 BV 1SR	-WGM 230

2.11.2 "Solenoid voltage and connector"

2.18.1 "Basic type and size"

2.18.1 Basic type and size

Type	Description	Flow rate Q_{max} (lpm)	Pressure p_{max} (bar)
NZP 16 BV 1RS	Pendulum valve Neutral position: B → T	20	400
NZP 16 BV 1SR	Pendulum valve Neutral position: A → T	20	400

⚠ CAUTION

Risk of injury if the device is operated outside the permitted pressure and flow rate ranges.

Risk of minor injury

- Observe the permitted pressure and flow rate ranges of the directional valves being used.

2.19 Intermediate plate with quick shut-down valve: SK 7788 590

Circuit symbol

SK 7788 590

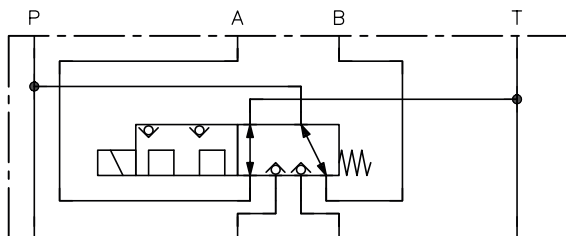

Detailed

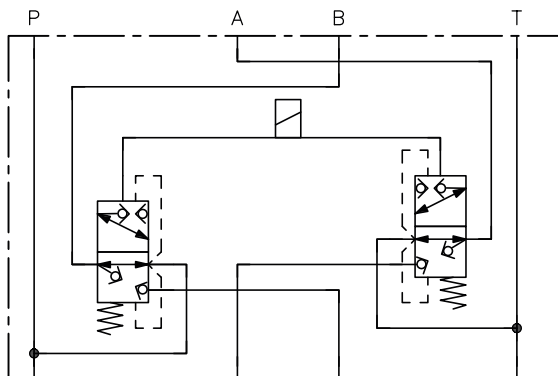

Ordering example

SK 7788 590 R /AB1/BBV2 /S -X 24
SK 7788 590 -H 1/4

2.11.2 "Solenoid voltage and connector"

2.24 "Additional element" at T

2.24 "Additional element" at A and/or B

2.24 "Additional element" at P

2.19.1 "Basic type and size"

2.19.1 Basic type and size

Type	Description	Flow rate Q_P (lpm)	Pressure p_{max} (bar)	
			A, B, P	T
SK 7788 590	Quick shut-down valve	20	400	50

Δp at 20 lpm approx. 17 bar



CAUTION

Risk of injury if the device is operated outside the permitted pressure and flow rate ranges.

Risk of minor injury

- Observe the permitted pressure and flow rate ranges of the directional valves being used.

2.20 Intermediate plate with releasable check valves at A and B: NZP 16 ADRH

Circuit symbol

NZP 16 ADRH

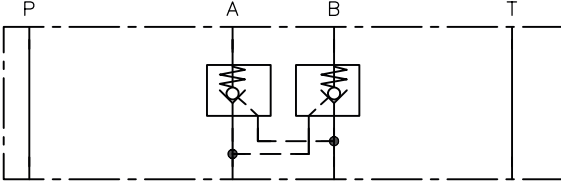

Ordering example

NZP 16 ADRH

2.20.1 "Basic type and size"

2.20.1 Basic type and size

Type	Description	Flow rate Q_p (lpm)	Pressure p_{max} (bar)
NZP 16 ADRH	Releasable check valves at A and B, pilot ratio 3.3:1	50	350



CAUTION

Risk of injury if the device is operated outside the permitted pressure and flow rate ranges.

Risk of minor injury

- Observe the permitted pressure and flow rate ranges of the directional valves being used.

2.21 Intermediate plate with shock valve: NZP 16 AN.. and others

Circuit symbol

NZP 16 - AN..
NZP 16 - AXN..

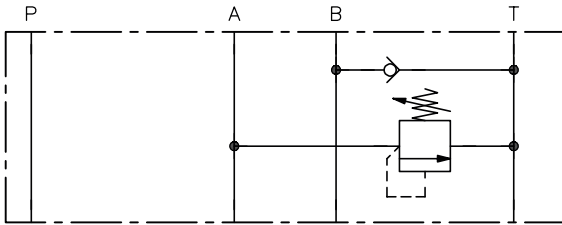

NZP 16 - A.. B..
NZP 16 - AX.. BX..

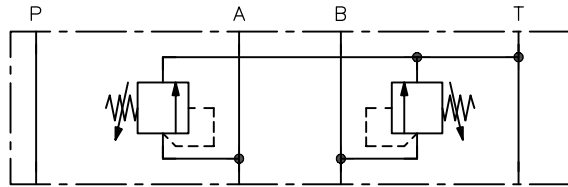

NZP 16 - A..
NZP 16 - AX..

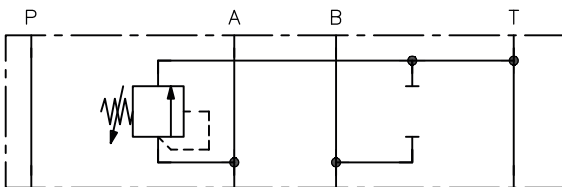

NZP 16 - B..
NZP 16 - BX..

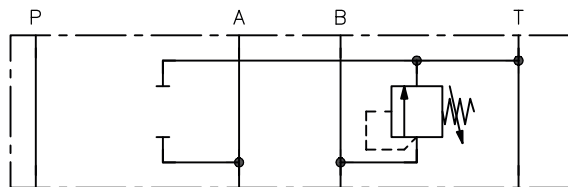

NZP 16 - BN..
NZP 16 - BXN..

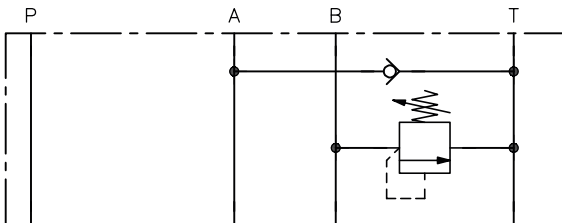

NZP 16 - ANBN

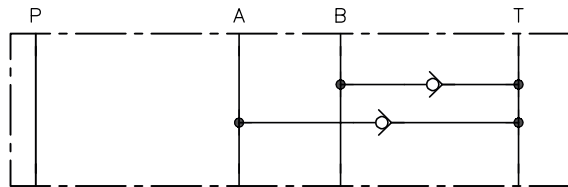

NZP 16 - AXBX

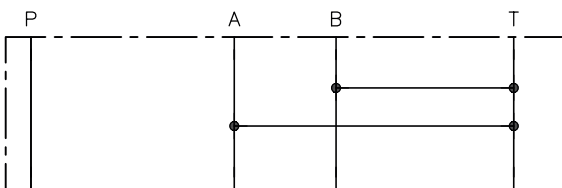

Ordering example

NZP 16	A..	/B..
NZP 16	AN..	
NZP 16		BXN..

Shock valve with/without damping at B with pressure setting (bar) and optional anti-cavitation valve on opposite port

Shock valve with/without damping at A with pressure setting (bar) and optional anti-cavitation valve on opposite port

2.21.1 "Basic type and size"

2.21.1 Basic type and size

Type	Description	Flow rate Q _{max} (lpm)	Pressure p _{max} (bar)
NZP 16 AN..	Shock valve at A Anti-cavitation valve at B	20	500
NZP 16 AXN..	Shock valve without damping at A Anti-cavitation valve at B	20	500
NZP 16 BN..	Shock valve at B Anti-cavitation valve at A	20	500
NZP 16 BXN..	Shock valve without damping at B Anti-cavitation valve at A	20	500
NZP 16 A..B..	Shock valve at A and B	20	500
NZP 16 AX..BX..	Shock valve without damping at A and B	20	500
NZP 16 A.. NZP 16 B..	Shock valve at A or B	20	500
NZP 16 AX.. NZP 16 BX..	Shock valve without damping at A or B	20	500
NZP 16 ANBN	Servo-suction valve at A and B	20	500
NZP 16 AXBX	Free passage from A to T and B to T	(20)	(500)

Valve used:

- Pressure-limiting valve type MVK 4 according to [D 7000 E/1](#)



CAUTION

Risk of injury if the device is operated outside the permitted pressure and flow rate ranges.

Risk of minor injury

- Observe the permitted pressure and flow rate ranges of the directional valves being used.

2.22 Intermediate plate with load-holding valve: NZP 16 AL, NZP 16 BL

Circuit symbol

NZP 16 AL-..

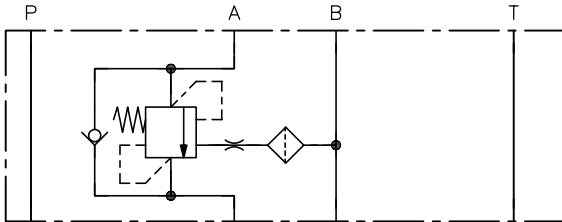

NZP 16 BL-..

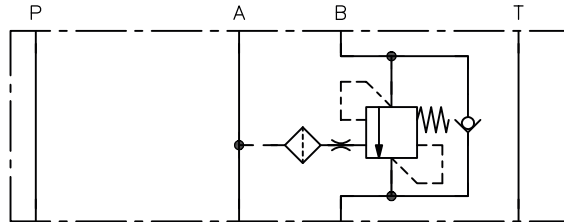

NZP 16 AL-..- BL-..

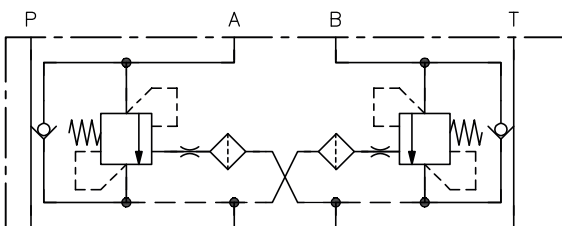

Ordering example

NZP 16 AL	-A8	/250	V	-BL	-A8	/250	V
NZP 16 AL	-C4	/300					

2.22.3 "Adjustment"

Pressure setting

2.22.2 "Flow rate and pilot ratio"

2.22.1 "Basic type and size"

2.22.3 "Adjustment"

Pressure setting

2.22.2 "Flow rate and pilot ratio"

2.22.1 "Basic type and size"

2.22.1 Basic type and size

Type	Description	Pressure p _{max} (bar)
NZP 16 AL-..	Load-holding valves at A	400
NZP 16 BL-..	Load-holding valves at B	400
NZP 16 AL-..-BL-..	Load-holding valves at A and B	400

Valve used

- Load-holding valve type LHT 2 according to [D 7918](#)



CAUTION

Risk of injury if the device is operated outside the permitted pressure and flow rate ranges.

Risk of minor injury

- Observe the permitted pressure and flow rate ranges of the directional valves being used.

2.22.2 Flow rate and pilot ratio

Coding	Pilot ratio		Recommended flow rate (lpm)
	1:8	1:4	
A8	●		28
A4		●	
B8	●		14
B4		●	
C8	●		10
C4		●	
D8	●		6
D4		●	
E8	●		3
E4		●	

2.22.3 Adjustment

Coding	Comment
without coding	Fixed
V	Adjustable

2.23 Spacer plate

Circuit symbol

NZP 16 D

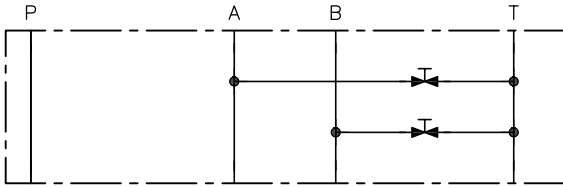

NZP 16 Z10

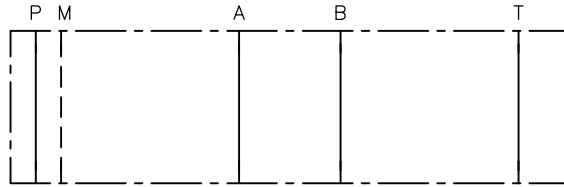

NZP 16 ZA RB

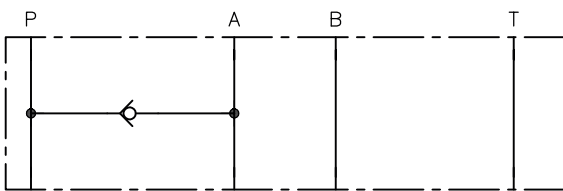

NZP 16 ZA RK

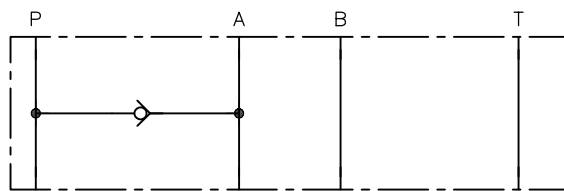

NZP 16 AB-BA

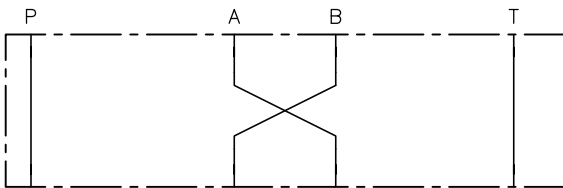

Ordering example

NZP 16 D			
NZP 16 Z10	/B2,0	/ABV2,0 BBV1,0	S
			2.24.1 "Additional element at T"
			2.24.1 "Additional element at A and B"
			2.24.1 "Additional element at P"
			2.23.1 "Basic type and size"

2.23.1 Basic type and size

Type	Description
NZP 16 D	Drain valves at A/B → T
NZP 16 Z10	Intermediate plate 10 mm required for directional seated valves Type NBVP 16 ...- M 24 / 8W (Solenoid size)
NZP 16 ZA RB	Short-circuit direction P → A
NZP 16 ZA RK	Short-circuit direction A → P
NZP 16 AB-BA	Adapter plate 8144 030 for swapping over consumer ports. Is required e.g. for 1:1 swap of NBVP 16 G with ROLV 14 G-N or NBVP 16 W with ROLV 14 W-N



NOTICE

Additional elements only for type NZP 16 Z10.

2.24 Additional element

Additional element at P

Coding	Comment
without coding	without
R	Check valve (plug-in valve)
B 0,4	Orifice with orifice diameter in mm (Screw-in valve)
B 0,5	
B 0,6	
B 0,7	
B 0,8	
B 0,9	
B 1,0	
B 1,1 *	
B 1,2	
B 1,4 *	
B 1,5	
B 1,8 *	
B 2,0	
B 2,4 *	
B 2,5	
B 3,0 *	
B 3,5 *	
B 4,0 *	

NOTICE

- It is possible to combine the orifice and the check valve, e.g. /RB 1.0, not in the case of NZP 16 Z10
- Options marked with * not for type NZP 16 Z10

Additional element at T

Coding	Comment
without coding	without
S	Return pressure stop (plug-in valve)
S1	Return pressure stop (plug-in valve) Opening pressure approx. 1 bar
S0.2	Return pressure stop (plug-in valve) Opening pressure approx. 0.2 bar
	Orifice with orifice diameter in mm (plug-in valve)
TB 0.4	∅ 0.4
TB 0.5	∅ 0.5
TB 0.6	∅ 0.6
TB 0.7	∅ 0.7
TB 0.8	∅ 0.8
TB 0.9	∅ 0.9
TB 1.0	∅ 1.0
TB 1.2	∅ 1.2
TB 1.5	∅ 1.5
TB 2.0	∅ 2.0
TB 2.5	∅ 2.5

CAUTION

Risk of injury and possible material damage if operated outside the permitted pressure and flow rate ranges.

- Observe the permissible return pressure of the directional valve being used.

Additional element at A and/or B

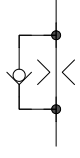
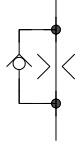
Coding		Comment	Circuit symbol	Diameter Ø mm
at A	at B			
AB 0.4	BB 0.4	Orifice A and/or B (Plug-in valve)		0,4
AB 0.5	BB 0.5			0,5
AB 0.6	BB 0.6			0,6
AB 0.7	BB 0.7			0,7
AB 0.8	BB 0.8			0,8
AB 0.9	BB 0.9			0,9
AB 1.0	BB 1.0			1,0
AB 1.2	BB 1.2			1,2
AB 1.5	BB 1.5			1,5
AB 2.0	BB 2.0			2,0
AB 2.5	BB 2.5	2,5		
ABV 0.6	BBV 0.6	Restrictor check valve at A and/or B to the consumer, throttling (Plug-in valve)		0,6
ABV 0.7	BBV 0.7			0,7
ABV 0.8	BBV 0.8			0,8
ABV 0.9	BBV 0.9			0,9
ABV 1.0	BBV 1.0			1,0
ABV 1.2	BBV 1.2			1,2
ABV 1.5	BBV 1.5			1,5
ABV 2.0	BBV 2.0	2,0		
ABR 0.6	BBR 0.6	Restrictor check valve at A and/or B to the consumer, open (Plug-in valve)		0,6
ABR 0.7	BBR 0.7			0,7
ABR 0.8	BBR 0.8			0,8
ABR 0.9	BBR 0.9			0,9
ABR 1.0	BBR 1.0			1,0
ABR 1.2	BBR 1.2			1,2
ABR 1.5	BBR 1.5			1,5
ABR 2.0	BBR 2.0	2,0		

NOTICE

The versions ABR, BBR and ABV, BBV are structurally identical; installation position different.

3 Parameters

3.1 General data

Designation	Intermediate plate for hole pattern NG 6 according to DIN 24 340-A6
Design	Depending on type
Model	Depending on type
Material	Main valve ZnNi; solenoid electrogalvanised / zinc-nickel coated, SVNE8, SVSE 8 galvanised zinc coating with Cr(VI)-free passivation
Attachment	Via through bore with the screws of the directional valve. <div style="border: 1px solid black; padding: 5px;"> <p> NOTICE For pressures above 400 bar, high-strength screws (property class 10.9 at minimum) must be used.</p> </div>
Installation position	As desired
Hydraulic fluid	Hydraulic fluid, according to DIN 51 524 Parts 1 to 3; ISO VG 10 to 68 according to DIN ISO 3448 Viscosity range: 4 - 1500 mm ² /s Optimal operating range: approx. 10 - 500 mm ² /s Also suitable for biologically degradable hydraulic fluids type HEPG (polyalkylene glycol) and HEES (synthetic ester) at operating temperatures up to approx. +70°C.
Cleanliness level	ISO 4406 <u>21/18/15...19/17/13</u>
Temperatures	Environment: approx. -40 to +80 °C, hydraulic fluid: -25 to +80 °C, pay attention to the viscosity range. Start temperature: down to -40 °C is permissible (take account of the start viscosities!), as long as the steady-state temperature is at least 20 K higher during subsequent operation. Biologically degradable hydraulic fluids: note manufacturer specifications. With consideration for the seal compatibility, not above +70°C.

3.2 Weight

Intermediate plates

Type	
NZP 16 Q	= 0.8 kg
NZP 16 V(S, VP, SP)	= 1.4 kg
NZP 16 TV(S, VP, SP)	= 1.4 kg
NZP 16 CZ, NZP 26 CZ, NZP 16 LZ, NZP 16 ALZ, NZP 16 BLZ	= 1.7 kg
NZP 16 LZY	= 2.1 kg
NZP 16 ADK	= 1.7 kg
NZP 16 ACZ(BCZ)	= 1.7 kg
NZP 16 CZS	= 1.8 kg
NZP 16 ADM2	= 1.0 kg
NZP 16 PDM2	= 2.4 kg
NZP 16 SDM2	= 3.9 kg
NZP 16 BV..	= 1.4 kg
NZP 26 BV..	= 1.4 kg
NZP 16 PBV.., NZP 16 AT BV 1A(B)	= 1.4 kg
NZP 16 BV 1A.. - B..	= 1.7 kg
NZP 16 AL(BL)	= 1.0 kg
NZP 16 AL..BL..	= 1.2 kg
NZP 16 AN.., NZP 16 BN..	= 1.0 kg
NZP 16 AN.. BN..	= 1.2 kg
NZP 16 ANBN, NZP 16 AXBX	= 1.2 kg
NZP 16 Z10	= 0.2 kg
NZP 16 D	= 0.4 kg
NZP 16 ZA RB(RK)	= 0.4 kg
SK 7788 590	= 1.7 kg
NZP 16 ADRH	= 1.2 kg
NZP 16 SV(S) 8..(U)/A.(B.,P,T)	= 1.4 kg
NZP 16 SV(S) 8..(U)/AB.	= 1.9 kg
NZP 16 SV 8..(U)/ATBT	= 2.1 kg

3.3 Characteristic lines

NZP 16 Q...; NZP 16 ../P CQ.; NZP 16 T ../T CQ.

Δp -Q characteristic lines

Viscosity of the hydraulic fluid approx. 60 mm²/s

Throttled flow direction:

Reference values per revolution of the adjusting spindle

Counted from the closed state

Coding 1, 2, 3, CQ2

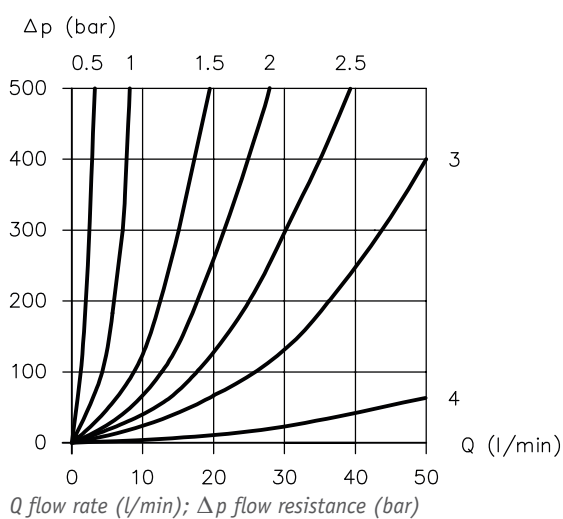

Coding 4, 5, 6, CQ2

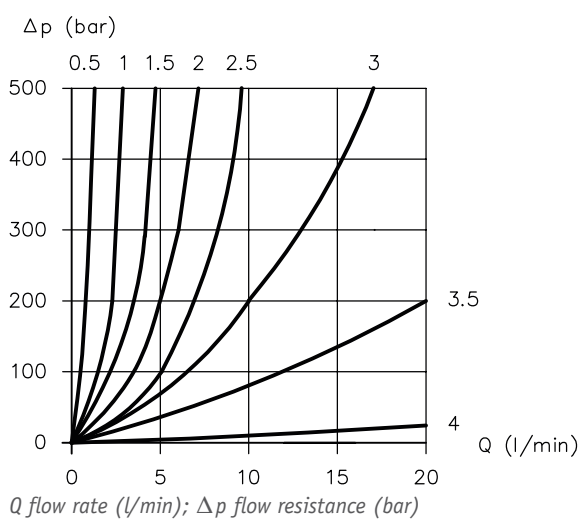

Free flow direction:

Coding 2, 3, 5, 6

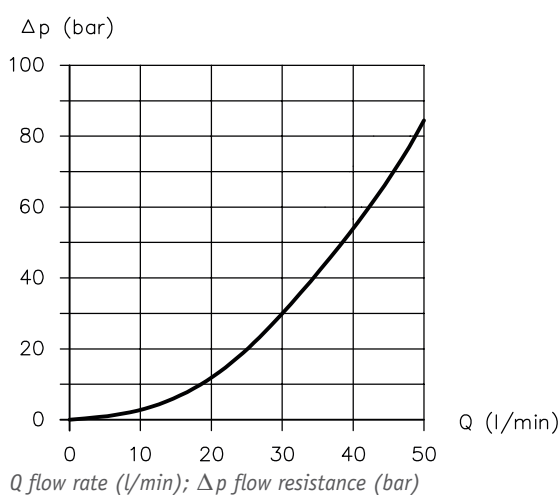

NZP 16 PDM

p/I characteristic line

NZP 16 PDM 2

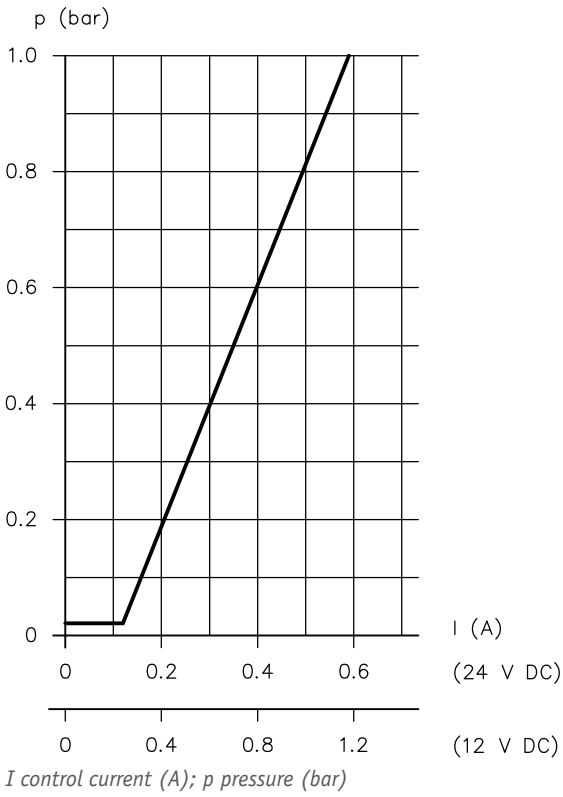

3.4 Electrical data

Nominal power P _N	12 V DC (X../XM..)	24 V DC (X../XM..)	98 V DC 110 V AC (WG../WGM..)	205 V DC 230 V AC (WG../WGM..)	24 V DC/ 8 watts
NZP 16..V NZP 16..S	21 W	21 W	21 W	21 W	--
NZP 16..VP NZP 16..SP NZP 16..VPG NZP 16..SPG	32 W	32 W	32 W	32 W	--
NZP 16..BV NZP 16 LZY	29 W / 26.5 W	28 W / 26.5 W	29 W / 25 W	30 W / 28 W	8 W
NZP 16 PDM 2-3	22 W	22 W	--	--	--
NZP 16 PDM 2-4	24 W	24 W	--	--	--
NZP 16 SDM	--	21 W	--	--	--
	12 V DC	24 V DC	102 V DC 115 V AC 50/60 Hz	205 V DC 230 V AC 50/60 Hz	
NZP 16 SV8 R NZP 16 SV8 R2	16 W	16 W	18 W	18 W	--
NZP 16 SV8 RU NZP 16 SV8 R2U NZP 16 SV8 S NZP 16 SV8 SU NZP 16 SV8 S2 NZP 16 SV8 S2U	26 W	26 W	26 W	26 W	--
NZP 16 SVS8 R NZP 16 SVS8 R2					
Current, cold I ₂₀	12 V DC (X../XM..)	24 V DC (X../XM..)	98 V DC 110 V AC (WG../WGM..)	205 V DC 230 V AC (WG../WGM..)	24 V DC/ 8 watts
NZP 16..V NZP 16..S	1.75 A	0.89 A	0.2 A	0.1 A	--
NZP 16..VP NZP 16..SP NZP 16..VPG NZP 16..SPG	2.67 A	1.33 A	0.3 A	0.15 A	--
NZP 16..BV NZP 16 LZY	2.5 A	1.25 A	0.3 A	0.15 A	--
NZP 16 PDM 2-3	1.8 A	0.88 A	--	--	--
NZP 16 PDM 2-4	2.0 A	1.0 A	--	--	--
NZP 16 SDM	--	0.9 A	--	--	--

Limit current I_G	12 V DC (X../XM..)	24 V DC (X../XM..)	98 V DC 110 V AC (WG../WGM..)	205 V DC 230 V AC (WG../WGM..)	24 V DC/ 8 watts
	NZP 16..VP NZP 16..SP NZP 16..VPG NZP 16..SPG	1.87 A	0.93 A	--	--
NZP 16 PDM 2-3	1.25 A	0.68 A	--	--	--
NZP 16 PDM 2-4	1.26 A	0.63 A	--	--	--
NZP 16 SDM	--	0.63 A	--	--	--
Nominal current I_N	12 V DC	24 V DC	102 V DC 115 V AC 50/60 Hz	205 V DC 230 V AC 50/60 Hz	
	NZP 16 SV(S)8..(U):				
16 W	1.33 A	0.66 A	--	--	--
18 W	--	--	0.18 A	0.09 A	--
26 W	2.17 A	1.08 A	0.25 A	0.13 A	--
Switching times	EIN		AUS		
	NZP 16..V NZP 16..S	S: 150 ms, V: 50 ms	S: 50 ms, V: 150 ms		
NZP 16..VP NZP 16..SP	SP: 150 ms, VP: 50 ms		SP: 50 ms, VP: 150 ms		
NZP 16..VPG NZP 16..SPG	SPG, VPG approx. 5 – 10 times longer				
NZP 16..BV NZP 16 LZY NZP 16 SV8...	50 – 60 ms		50 – 60 ms		
NZP 16 SDM	50 – 60 ms (1-2)		50 – 60 ms (1-2)		
for version WG.. approx. 2 – 3 times greater for version M24/8 W approx. 2 – 3 times greater					

Switching operations / h	Approx. 2000, to be seen as approximately evenly distributed
Insulation material class	F Contact temperature at 20° ambient temperature approx. 85 – 95°C (cladding). In adhering to the reference values for % duty cycle in operation, the permissible winding limit temperature of approx. 150°C according to insulation material class F is approximately reached as a steady-state temperature. The thermal load on the coil can be reduced by means of an economy circuit, for example, see Chapter 5.4, "Maintenance information"
Relative duty cycle 100% duty cycle (specified on solenoid)	Reference value and restriction in operation N.Z.P. 16 SV(S)8...100% duty cycle up to ambient temperature of 50°C ϑ_U (°C) ϑ_U ambient temperature (°C); % ED duty cycle
Protection class	Depending on the actuating solenoid see Chapter 2, "Available versions"
Electrical connection	Depending on the actuating solenoid see Chapter 2, "Available versions"

Circuit diagrams

DC voltage	<p>G., X..</p> <p>L..</p> <p>M..</p>
AC voltage	<p>WG 110, WG 230</p>
Cut-off energy	Approx. <10 Ws of maximum reference value + approx. 10% from measurements at nominal voltage U_N
Dither frequency	50 - 150 Hz

3.4.1 Electrical data for inductive position monitoring in the case of NZP 16 SV(S)8..U

Sensor electronics

Supply voltage U_B	24 V DC, $\pm 10\%$, regulated, residual ripple $< 10\%$
Protected against polarity reversal	integrated, to maximum 60 V DC
Current consumption I_B	< 50 mA (w/o external switching load)



Switch output

maximum switching current I_S	< 150 mA
Residual voltage of the switch output	< 2.5 V
Type	N/C contact/normally open contact, plus switching, overload-proof
minimum load resistance	200Ω

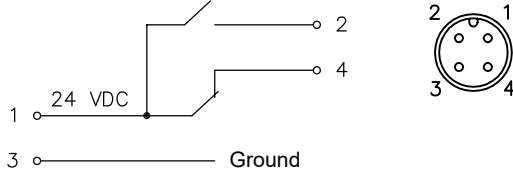
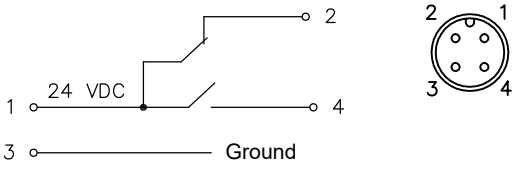
Electrical connection

Sensor connector	M12x1, 4-pole																				
Connection pattern	<div style="display: flex; justify-content: space-around;"> <div style="text-align: center;"> <p>SVNE..RU SVNE..R2U</p>  </div> <div style="text-align: center;"> <p>SVNE..SU SVNE..S2U</p>  </div> </div>																				
	<table border="1" style="display: inline-table; margin-right: 20px;"> <thead> <tr> <th>Pin</th> <th>Connection</th> </tr> </thead> <tbody> <tr> <td>1</td> <td>24 V DC supply</td> </tr> <tr> <td>2</td> <td>Normally open contact +</td> </tr> <tr> <td>3</td> <td>Ground</td> </tr> <tr> <td>4</td> <td>N/C contact +</td> </tr> </tbody> </table> <table border="1" style="display: inline-table;"> <thead> <tr> <th>Pin</th> <th>Connection</th> </tr> </thead> <tbody> <tr> <td>1</td> <td>24 V DC supply</td> </tr> <tr> <td>2</td> <td>N/C contact +</td> </tr> <tr> <td>3</td> <td>Ground</td> </tr> <tr> <td>4</td> <td>Normally open contact +</td> </tr> </tbody> </table>	Pin	Connection	1	24 V DC supply	2	Normally open contact +	3	Ground	4	N/C contact +	Pin	Connection	1	24 V DC supply	2	N/C contact +	3	Ground	4	Normally open contact +
Pin	Connection																				
1	24 V DC supply																				
2	Normally open contact +																				
3	Ground																				
4	N/C contact +																				
Pin	Connection																				
1	24 V DC supply																				
2	N/C contact +																				
3	Ground																				
4	Normally open contact +																				

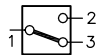
3.4.2 Electrical data for pressure switch for type NZP 16 ADK

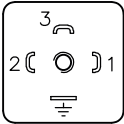
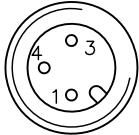
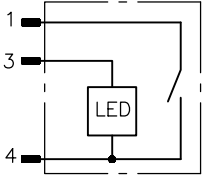
Mechanical lifetime	10 x 10 ⁶ switching cycles	
Switching current	Nominal voltage U_n	Switching current
	12 V DC	5 A
	24 V DC	2 A
<p>! NOTICE To ensure a safe contact, the current must not fall below certain minimum values: I_{min} (12 V DC) = 10 mA, I_{min} (24 V DC) = 100 mA</p>		
Line connector, electrical connection, protection class	Pressure switch	
	EN 175 301-803	M12x1
	IP 65 (according to IEC 60529)	IP 67 (according to IEC 60529)
	Normal position 1-3 Switching position 1-2	(LED indicator protected against polarity reversal) Switching position 1-4
	 	
	 	
		

4 Dimensions

All dimensions in mm, subject to change.

4.1 Intermediate plate with throttle valve: NZP 16 Q

Coding 1, 2, 3

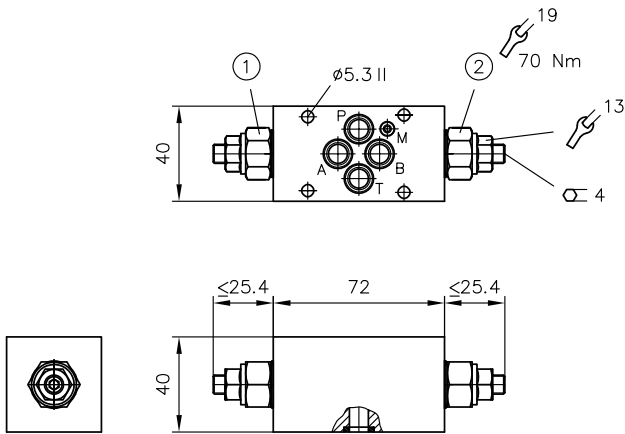

- 1 Throttle in the A channel
- 2 Throttle in the B channel

Coding 0

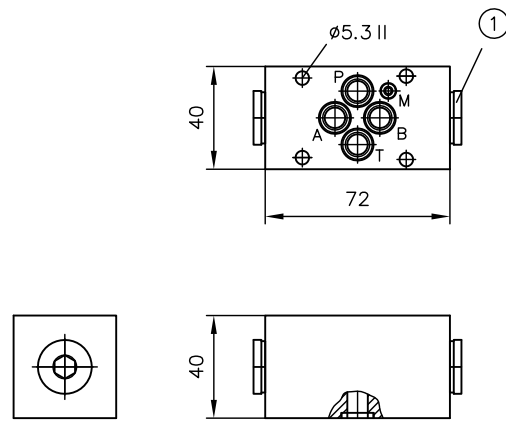

- 1 Tapped plug

Port M suitable for combination with clamping modules type NSMD according to [D 7787](#)

Hole pattern of the base plate

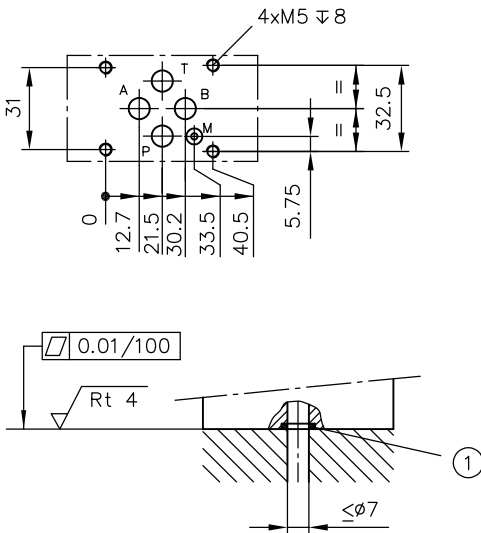

- 1 O-ring

Sealing of the ports:

	O-ring NBR 90 Sh
P, T, A, B	9.25x1.78
M	2.90x1.78

4.2 Intermediate plate with pressure reducing valve: N.ZP..CZ

N.ZP 16 CZ

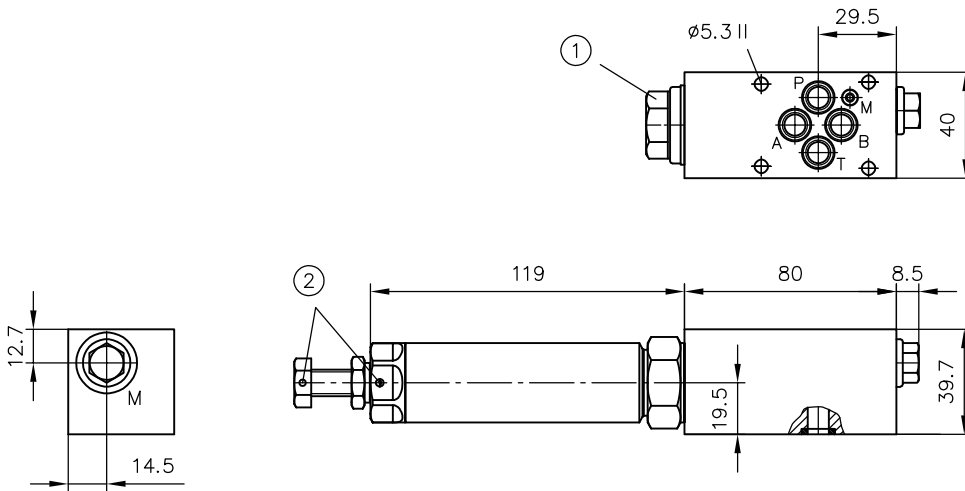

- 1 Tapped plug for CZX
- 2 Sealing option

N.ZP 26 CZ

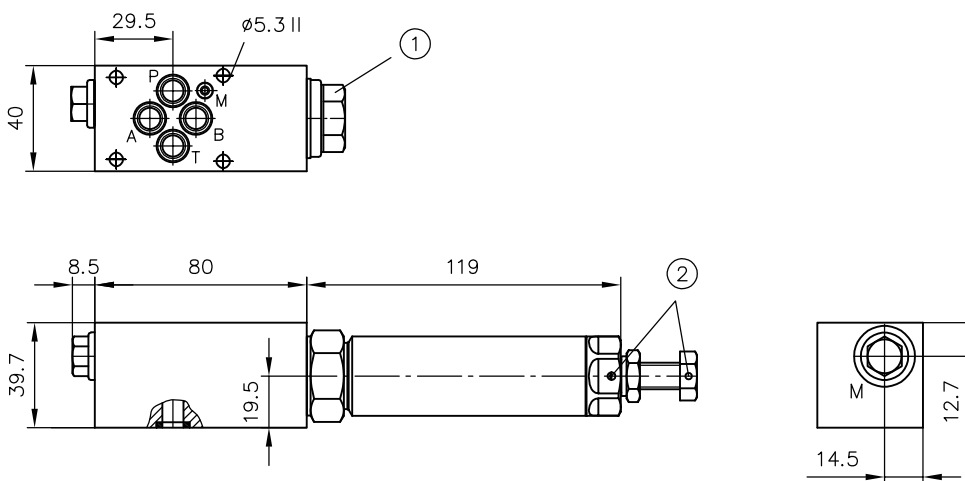

- 1 Tapped plug for CZX
- 2 Sealing option

Ports (ISO 228-1)

M	G 1/4
---	-------

NZP 16 CZS

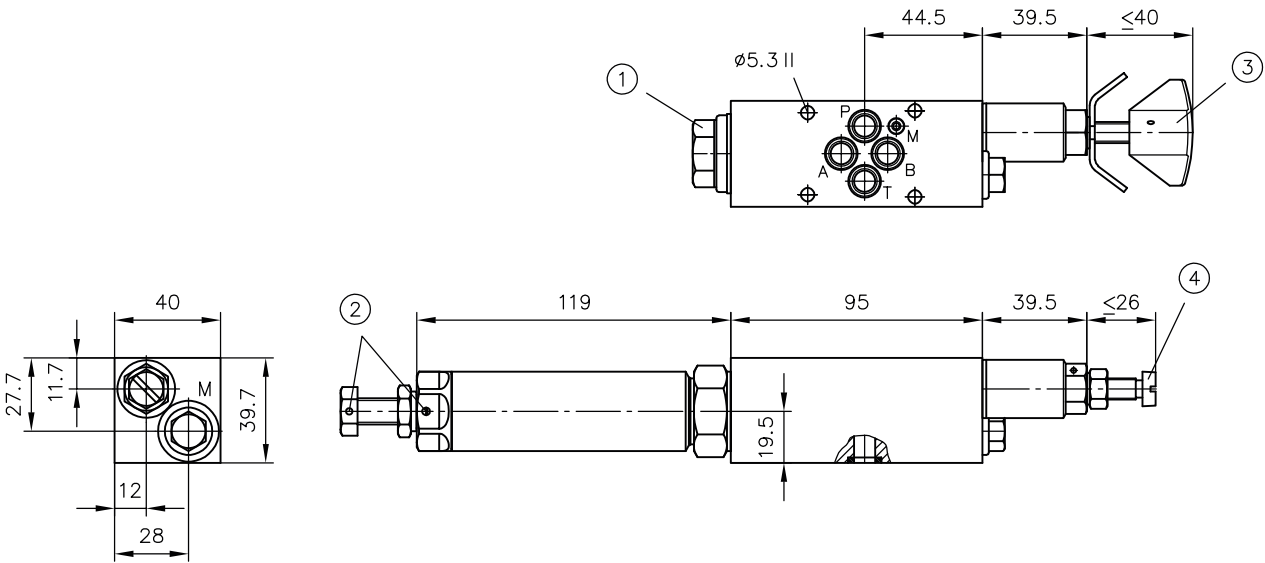

- 1 Tapped plug for CZSX
- 2 Sealing option
- 3 Adjustable, coding R
- 4 Fixed

NZP 16 ACZ

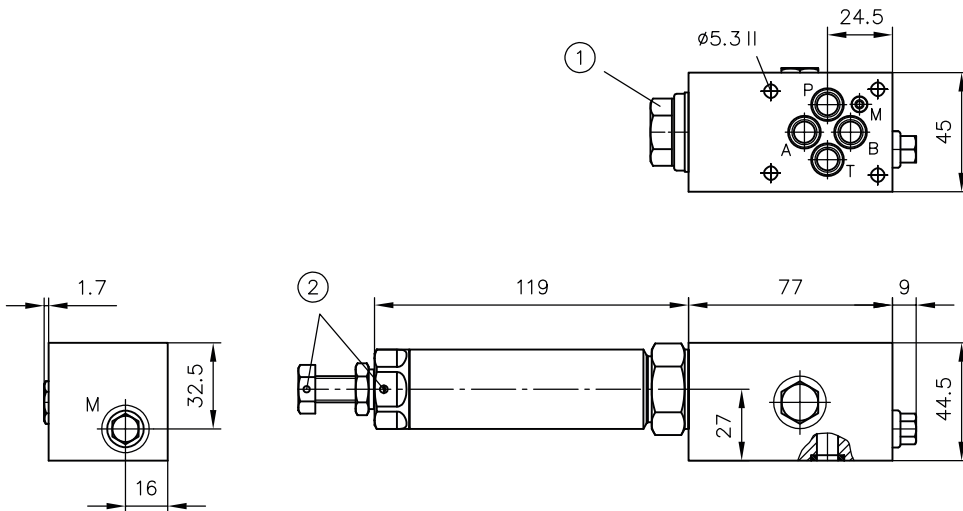

- 1 Tapped plug for ACZX
- 2 Sealing option

Ports (ISO 228-1)

M	G 1/8
---	-------

NZP 16 BCZ

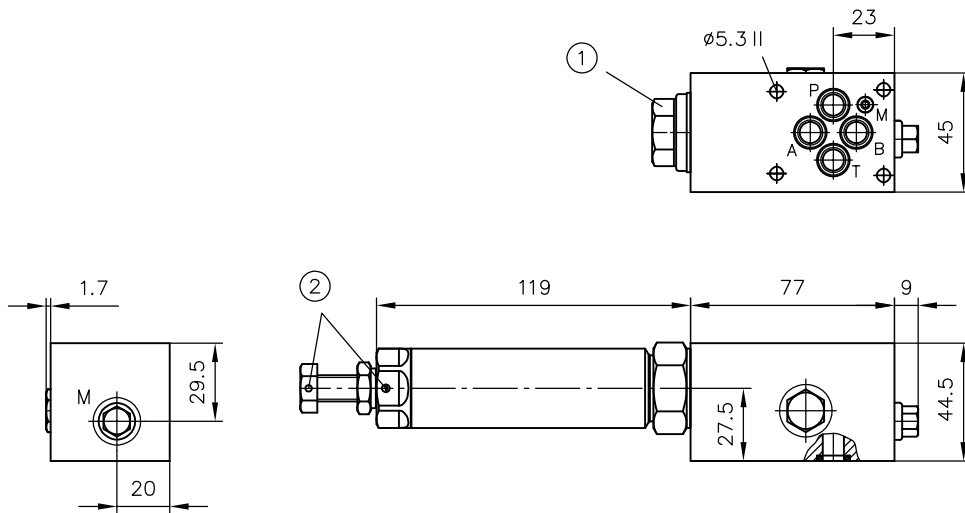

- 1 Tapped plug for BCZX
- 2 Sealing option

Ports (ISO 228-1)

M	G 1/8
---	-------

i INFORMATION

Missing dimensions and hole pattern, see Chapter 4.1, "Intermediate plate with throttle valve: NZP 16 Q".

Adjustment

Without coding

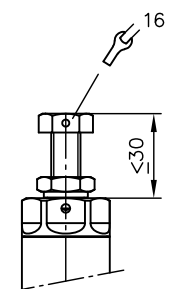

Coding R

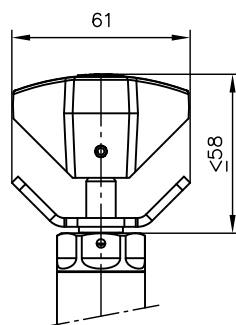

Coding H

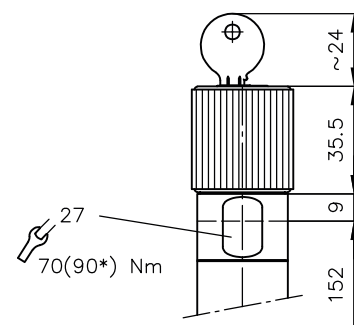

* CDK3.-08.

4.3 Intermediate plate with pressure reducing valve with tracked pressure switch at A: NZP 16 ADK

NZP 16 ADK

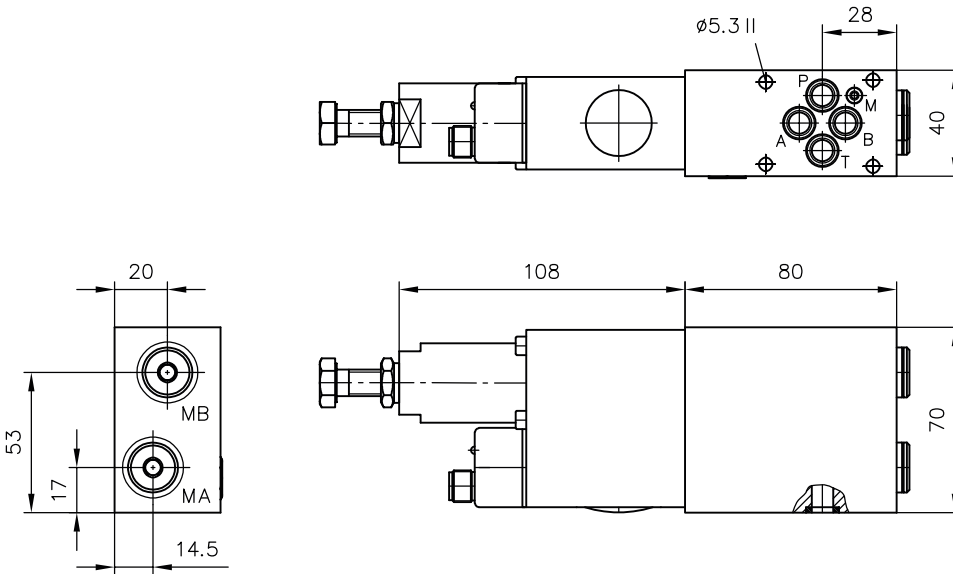

Ports (ISO 228-1)

MA, MB

G 1/4

i INFORMATION

Missing dimensions and hole pattern, see Chapter 4.1, "Intermediate plate with throttle valve: NZP 16 Q".

Adjustment

without coding

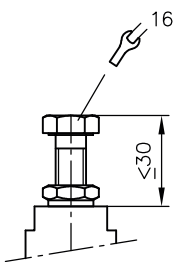

Coding R

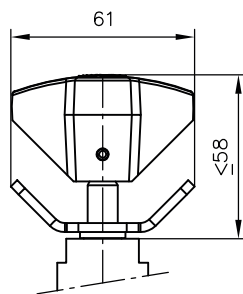

Coding H

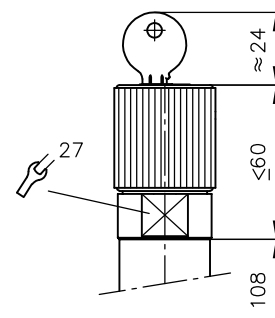

4.4 Intermediate plate with pressure reducing valve: NZP 16 LZ, NZP 16 ALZ, NZP 16 BLZ

NZP 16 LZ

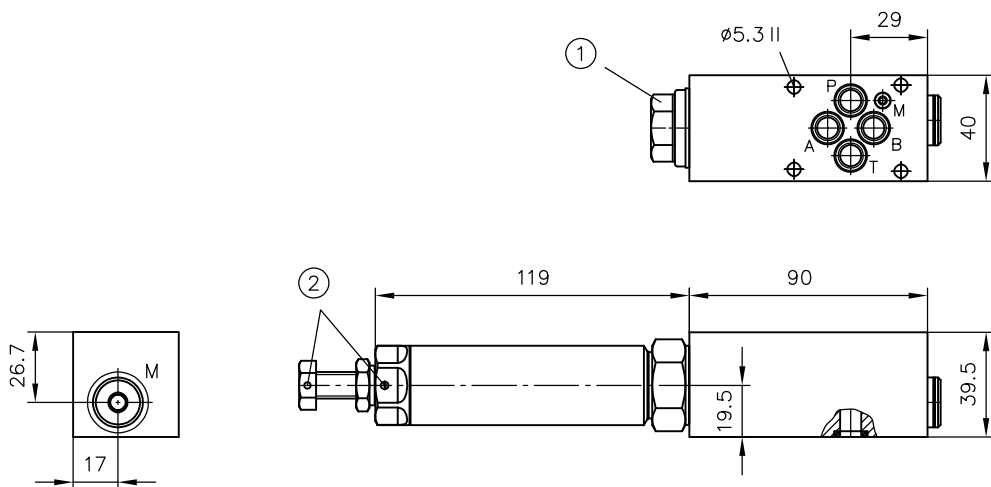

- 1 Tapped plug for LZX
- 2 Sealing option

Ports (ISO 228-1)

M	G 1/4
---	-------

NZP 16 ALZ

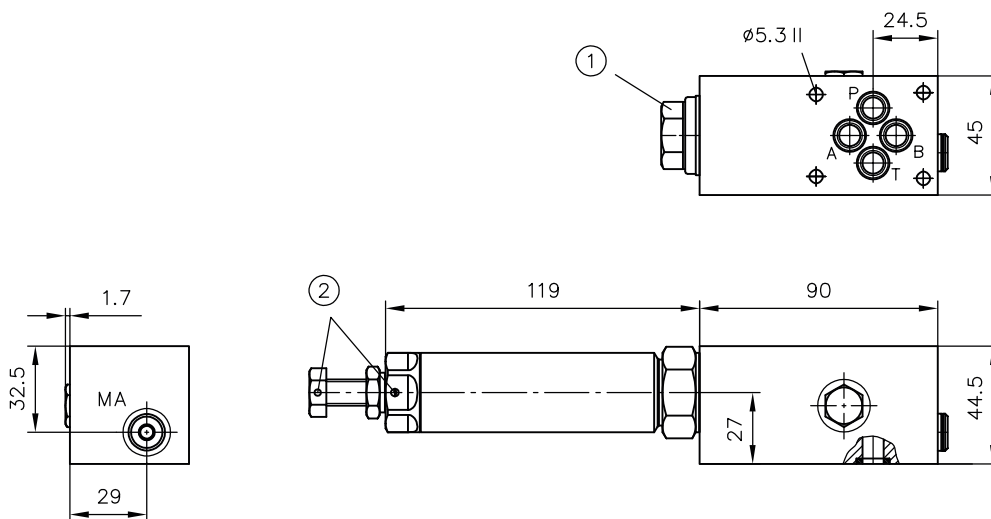

- 1 Tapped plug for ALZX
- 2 Sealing option

Ports (ISO 228-1)

MA	G 1/8
----	-------

NZP 16 BLZ

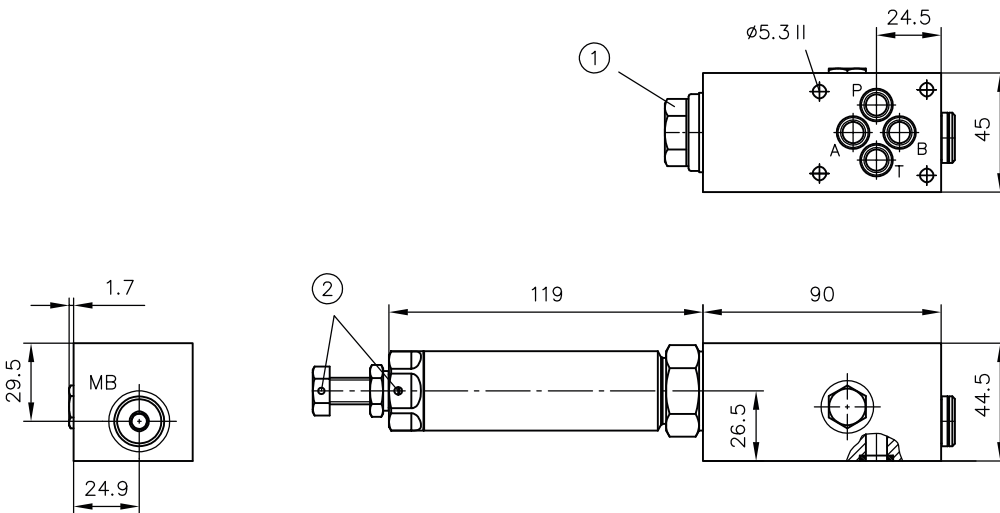

- 1 Tapped plug for BLZX
- 2 Sealing option

Ports (ISO 228-1)

MB	G 1/4
----	-------

i INFORMATION

Missing dimensions and hole pattern, see Chapter 4.1, "Intermediate plate with throttle valve: NZP 16 Q".

Adjustment

Without coding

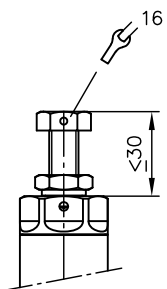

Coding R

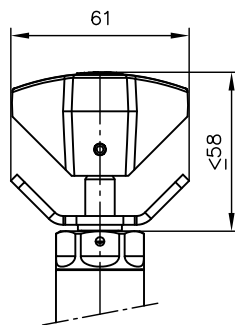

Coding H

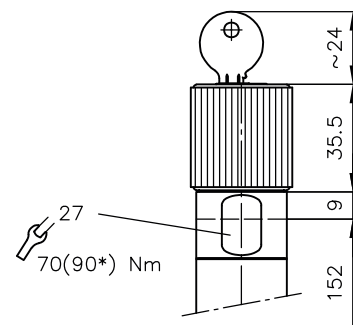

* CDK3.-08.

4.5 Intermediate plate with switchable pressure reducing valve at P: NZZ 16 LZ

NZZ 16 LZ

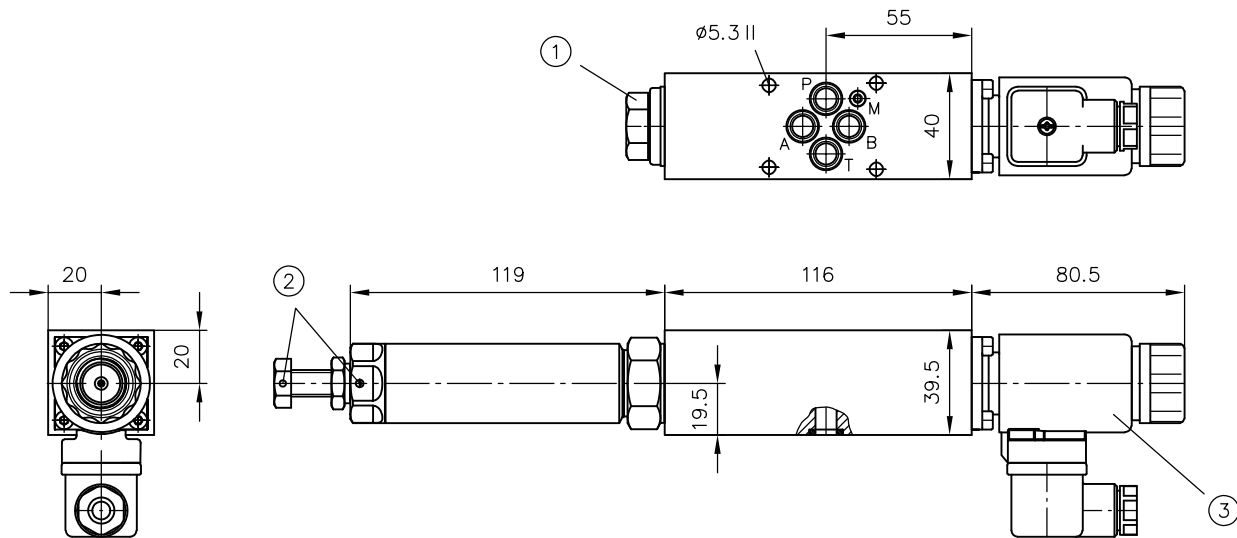

- 1 Tapped plug for LZYZ
- 2 Sealing option
- 3 Solenoid version

i INFORMATION

Missing dimensions and hole pattern, see Chapter 4.1, "Intermediate plate with throttle valve: NZZ 16 Q".

Actuation

X, G, WG

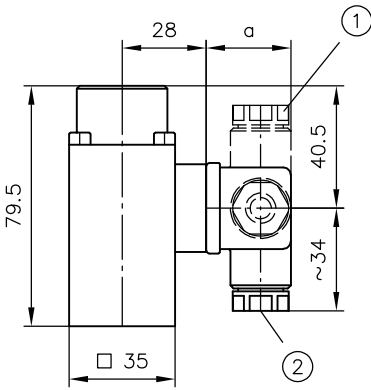

- 1 Plug can be mounted offset 4x 90°
- 2 Cable fitting

Version	a
G	28
WG	34,5

XM, GM, WGM

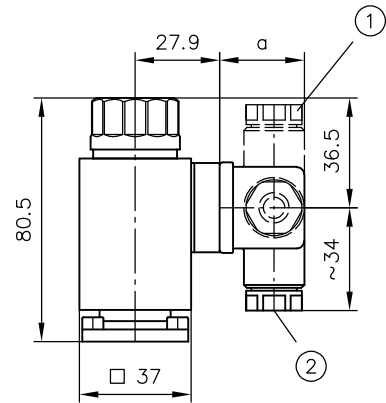

- 1 Plug can be mounted offset 4x 90°
- 2 Cable fitting

Manual override

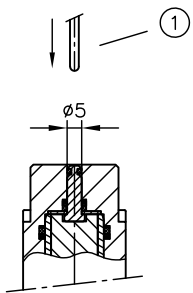

- 1 Auxiliary tool for actuation (do not use parts with sharp edges)

M 24/8W

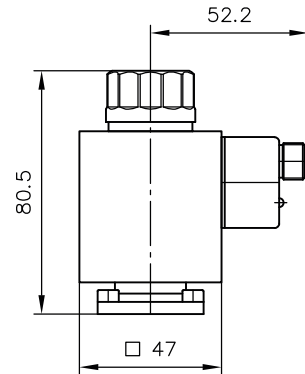

Adjustment

Without coding

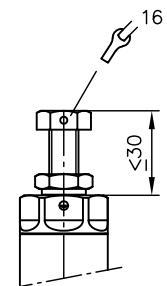

Coding R

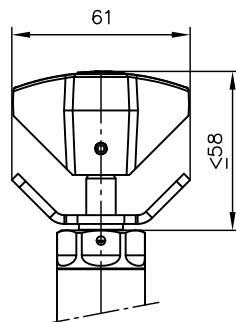

Coding H

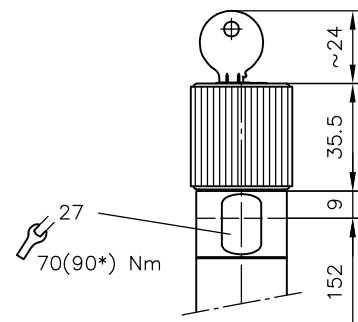

* CDK3.-08.

4.6 Intermediate plate with pressure reducing valve: NZP 16 ADM

NZP 16 ADM 2

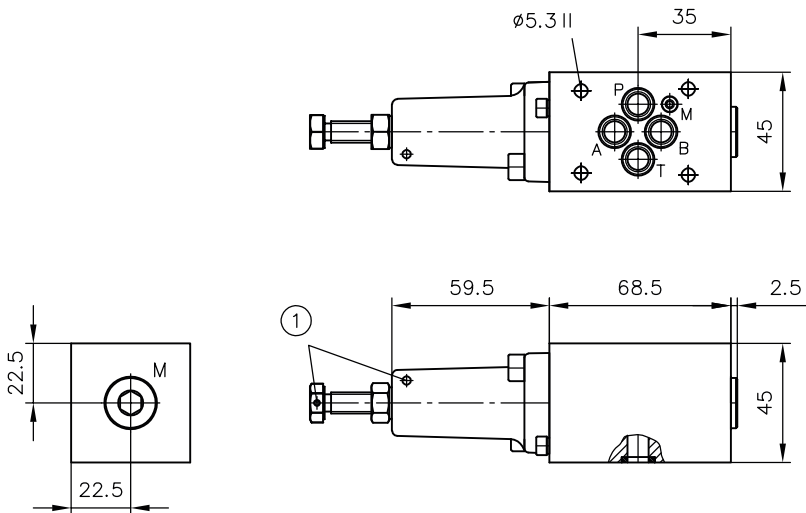

1 Sealing option

Ports (ISO 228-1)

M	G 1/4
---	-------

i INFORMATION

Missing dimensions and hole pattern, see Chapter 4.1, "Intermediate plate with throttle valve: NZP 16 Q".

Adjustment

fixed

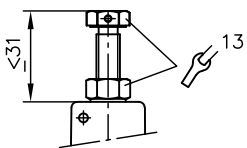

Manually adjustable

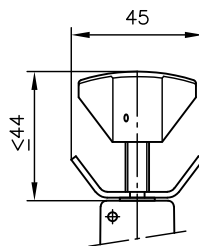

Lockable

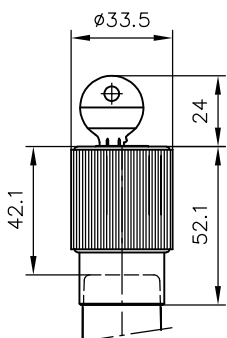

Turn knob

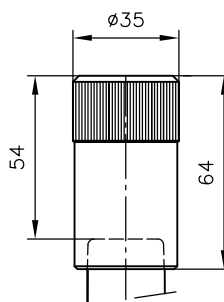

4.7 Intermediate plate with proportional pressure reducing valve: NZP 16 PDM

NZP 16 PDM 2

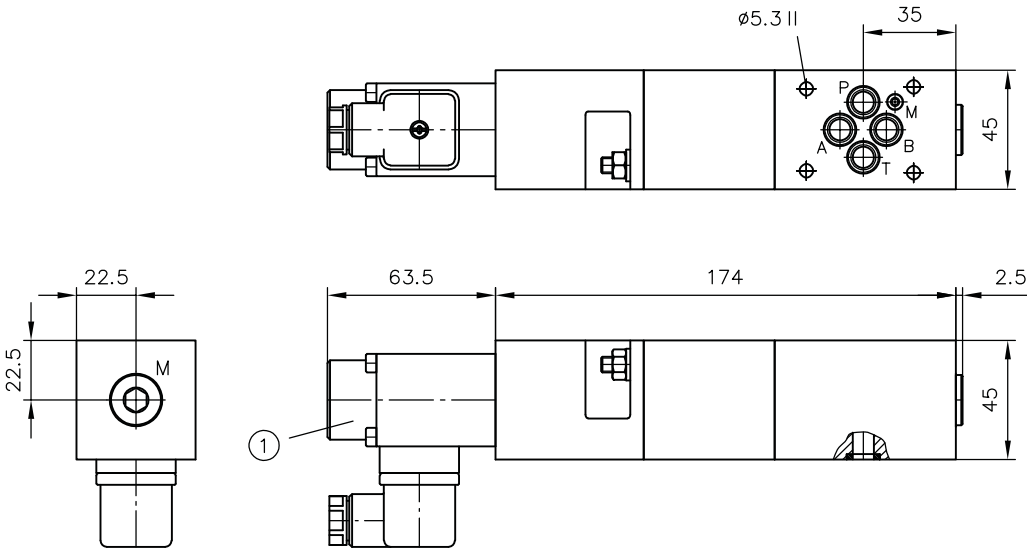

1 Solenoid version

Ports (ISO 228-1)

M	G 1/4
---	-------

i INFORMATION

Missing dimensions and hole pattern, see Chapter 4.1, "Intermediate plate with throttle valve: NZP 16 Q".

Actuation

NZP 16 PDM 2-3..

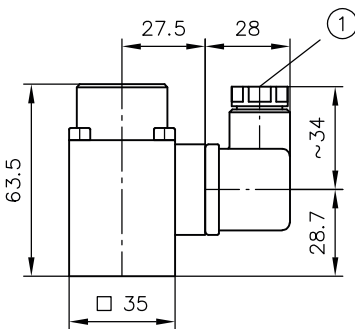

1 Cable gland

NZP 16 PDM 2-4..

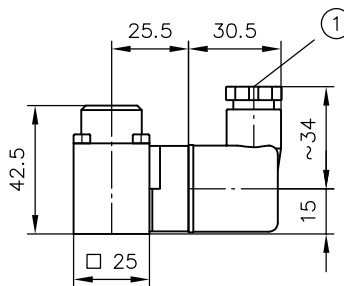

1 Cable gland

4.8 Intermediate plate with proportional pressure reducing valve at P: NZP 16 SDM

NZP 16 SDM 2

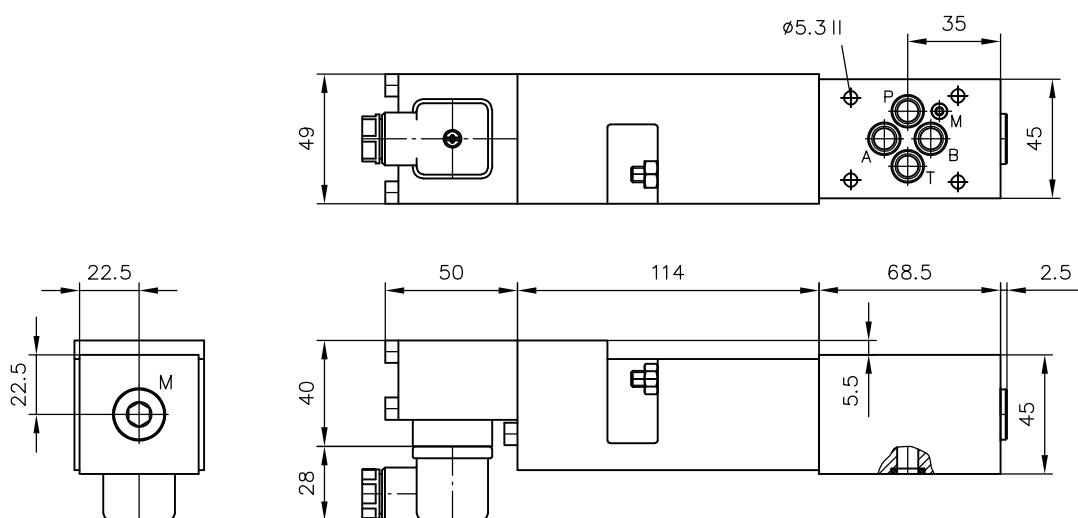

Ports (ISO 228-1)

M	G 1/4
---	-------

i INFORMATION

Missing dimensions and hole pattern, see Chapter 4.1, "Intermediate plate with throttle valve: NZP 16 Q".

4.9 Intermediate plate with randomly connectible 2nd Speed: NZP 16../P.., NZP 16T ../T..

NZP 16V/P..
NZP 16S/P..

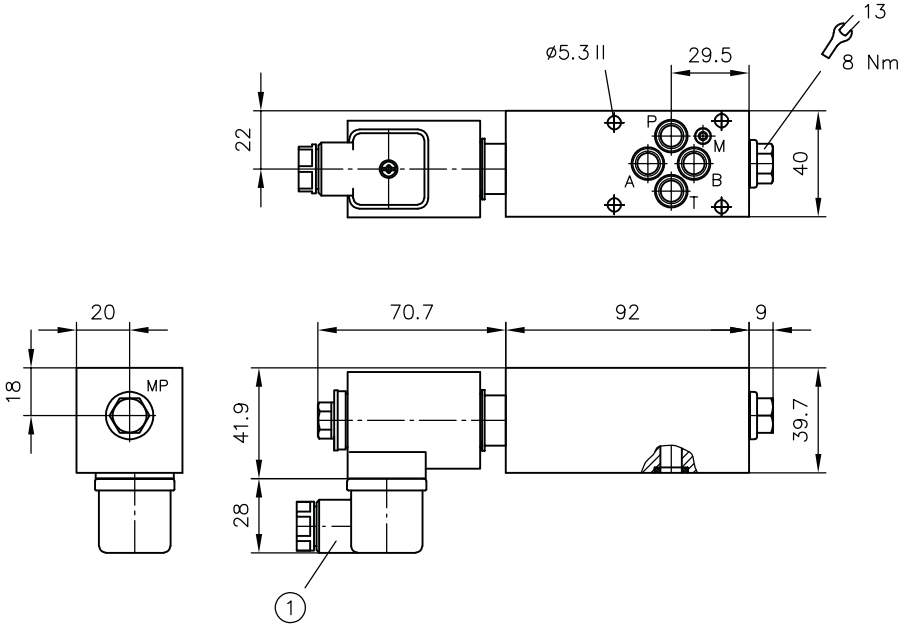

1 Solenoid can be turned in any direction

NZP 16V/PCQ..
NZP 16S/PCQ..

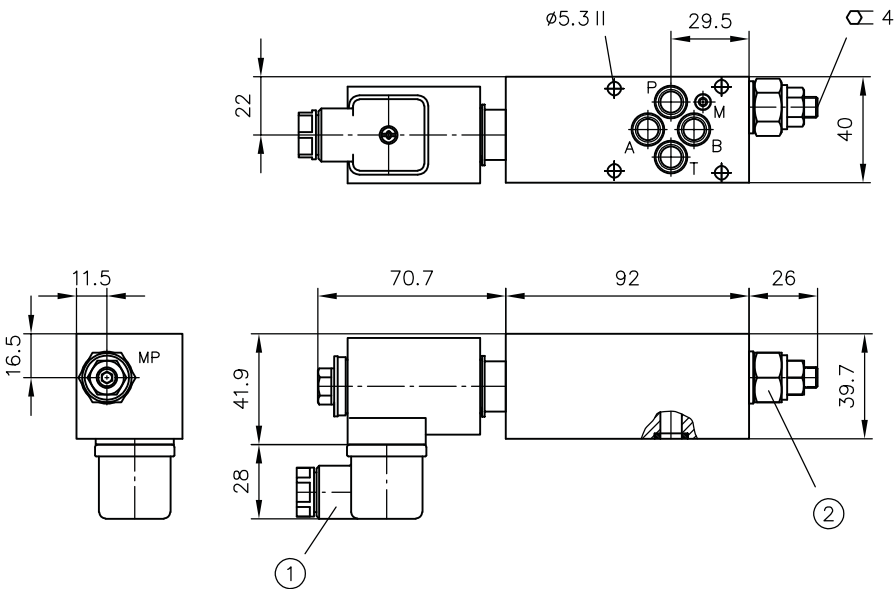

1 Solenoid can be turned in any direction
2 For version Q 20, maximum adjustment travel

Ports (ISO 228-1)

MP G 1/4

**NZP 16T V/T..
NZP 16T S/T..**

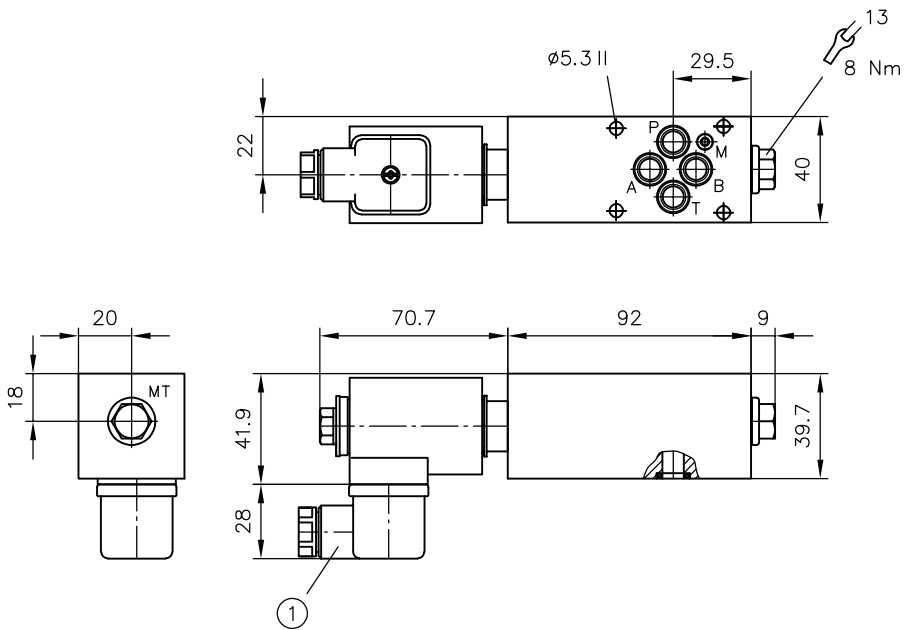

1 Solenoid can be turned in any direction

**NZP 16T V/TCQ..
NZP 16T S/TCQ..**

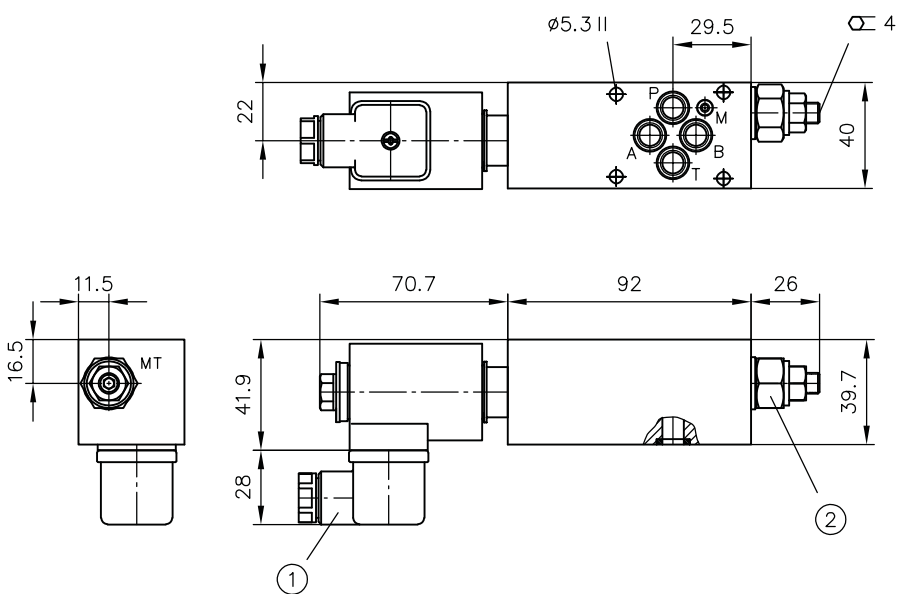

- 1 Solenoid can be turned in any direction
- 2 For version Q 20, maximum adjustment travel

Ports (ISO 228-1)

MT	G 1/4
----	-------

i INFORMATION

Missing dimensions and hole pattern, see Chapter 4.1, "Intermediate plate with throttle valve: NZP 16 Q".

**4.10 Intermediate plate with check valve with/without inductive position monitoring:
NZP 16 SV(S)8..(U)**

NZP 16 SV../A

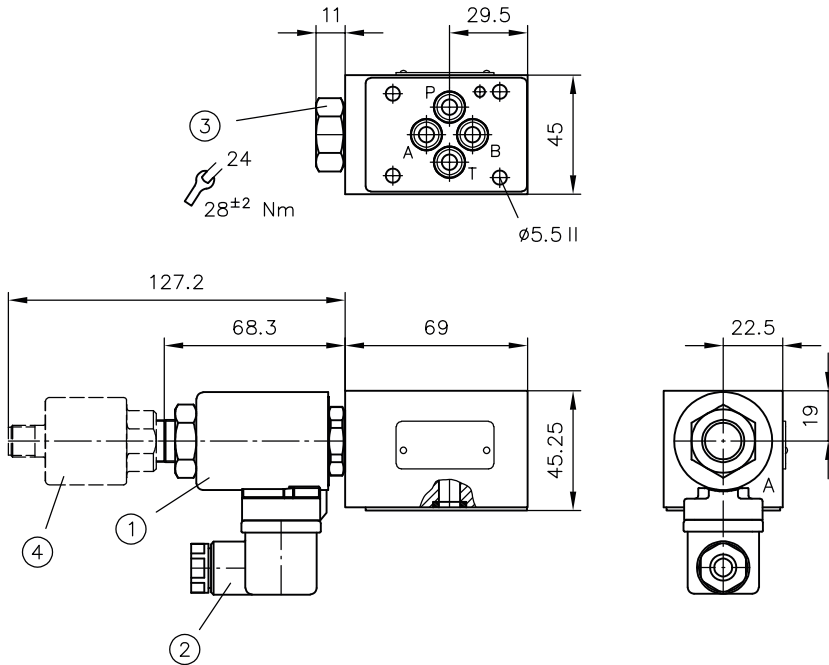

- 1 Solenoid version
- 2 Solenoid can be turned in any direction
- 3 Tapped plug for type NZP 16 SV8 X/A
- 4 Version U with additional position switch

NZP 16 SV../A1

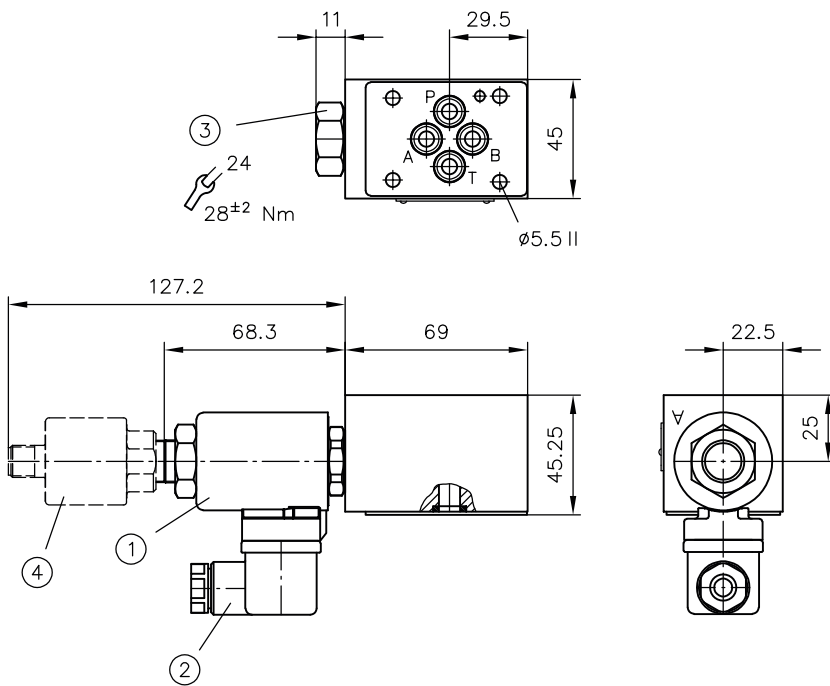

- 1 Solenoid version
- 2 Solenoid can be turned in any direction
- 3 Tapped plug for type NZP 16 SV8 X/A1
- 4 Version U with additional position switch

NZP 16 SV../B

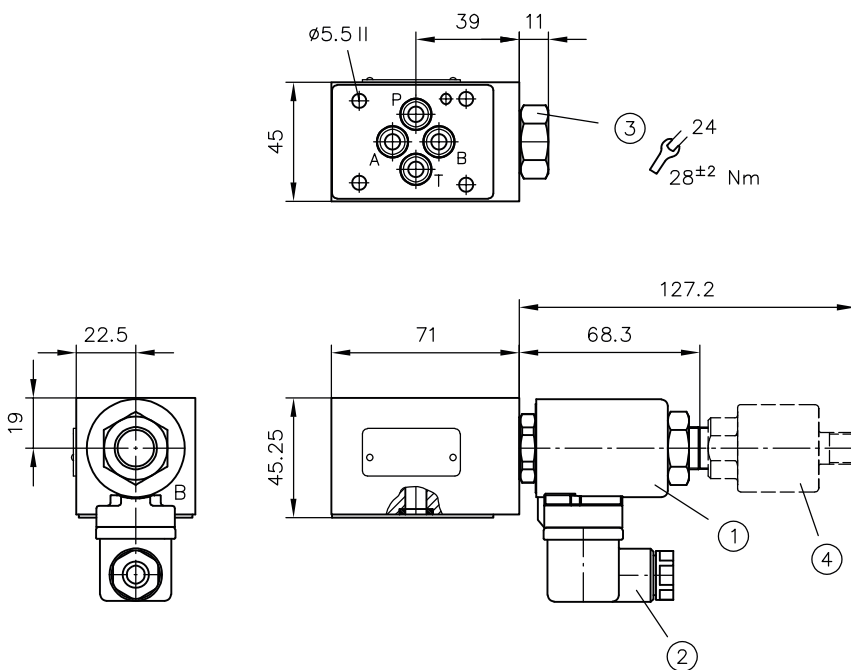

- 1 Solenoid version
- 2 Solenoid can be turned in any direction
- 3 Tapped plug for type NZP 16 SV8 X/B
- 4 Version U with additional position switch

NZP 16 SV../B1

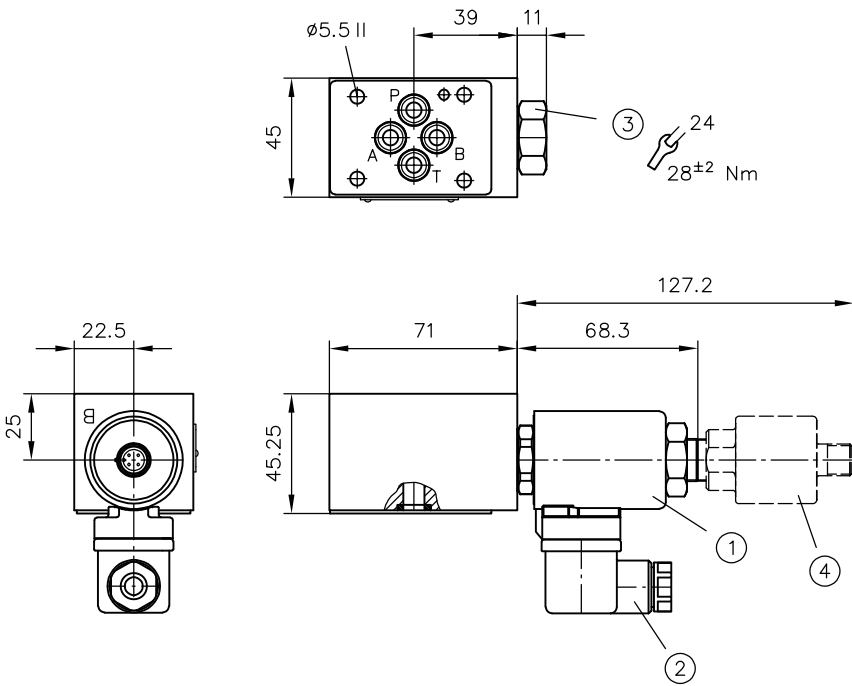

- 1 Solenoid version
- 2 Solenoid can be turned in any direction
- 3 Tapped plug for type NZP 16 SV8 X/B1
- 4 Version U with additional position switch

NZP 16 SV../AB

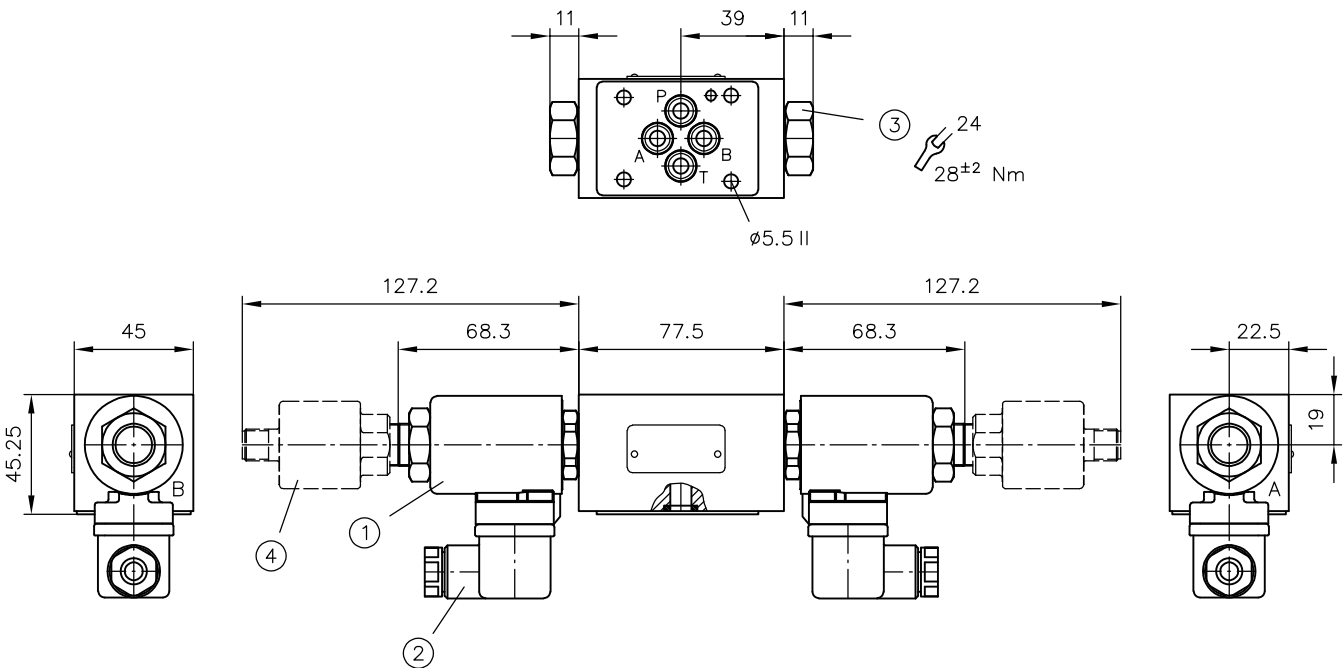

- 1 Solenoid version
- 2 Solenoid can be turned in any direction
- 3 Tapped plug for type NZP 16 SV8 X/AB
- 4 Version U with additional position switch

NZP 16 SV../AB1

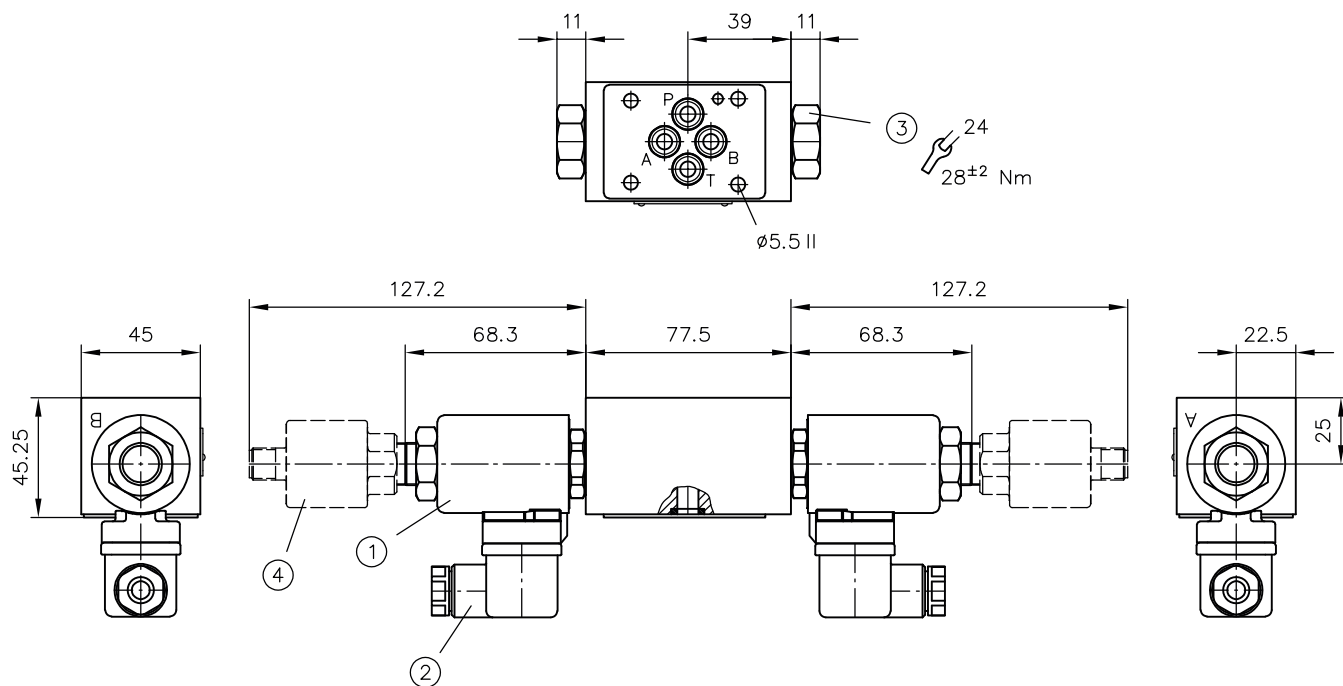

- 1 Solenoid version
- 2 Solenoid can be turned in any direction
- 3 Tapped plug for type NZP 16 SV8 X/AB1
- 4 Version U with additional position switch

NZP 16 SV../P

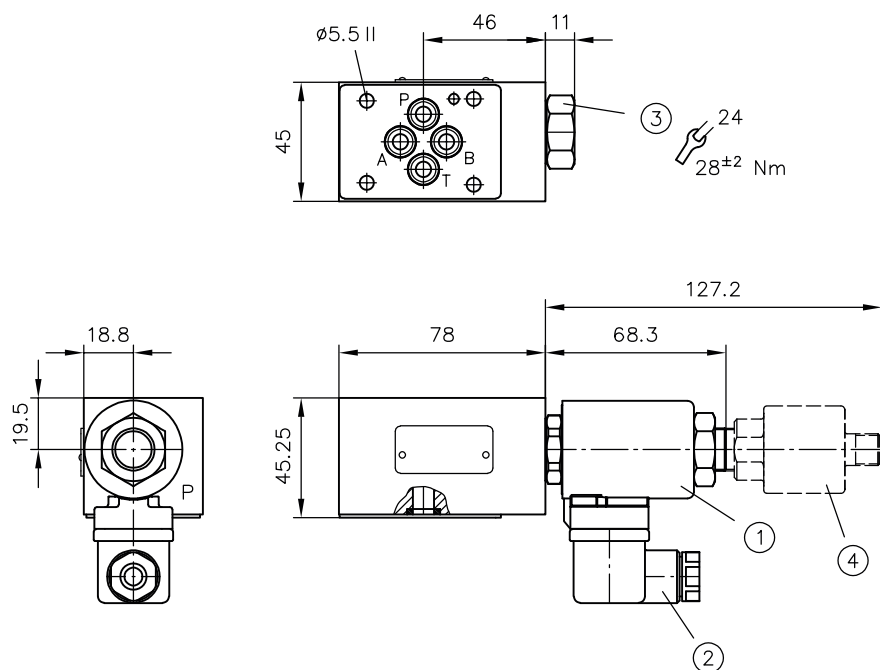

- 1 Solenoid version
- 2 Solenoid can be turned in any direction
- 3 Tapped plug for type NZP 16 SV8 X/P
- 4 Version U with additional position switch

NZP 16 SV../T

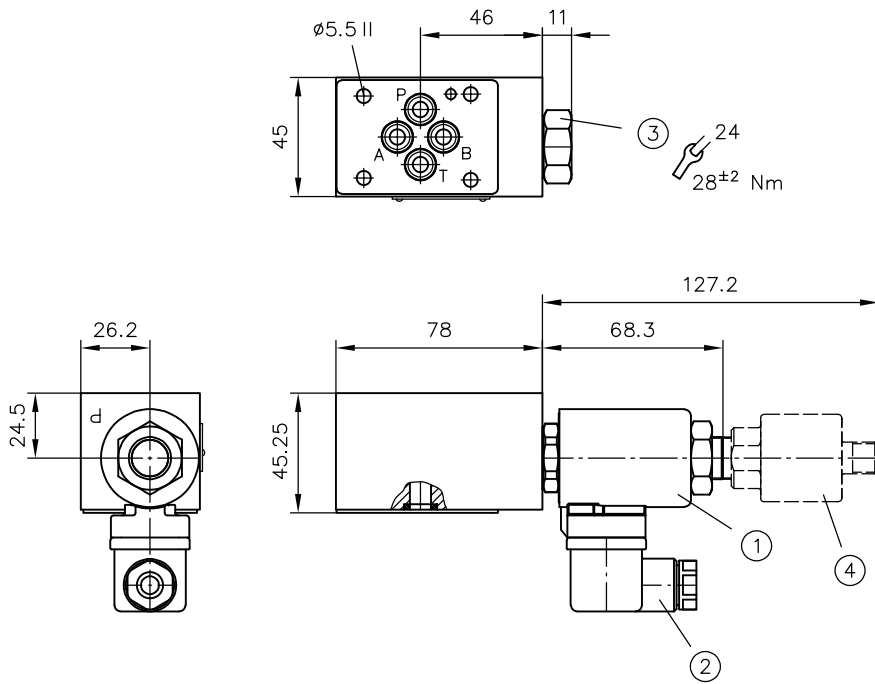

- 1 Solenoid version
- 2 Solenoid can be turned in any direction
- 3 Tapped plug for type NZP 16 SV8 X/T
- 4 Version U with additional position switch

NZP 16 SV../ATBT

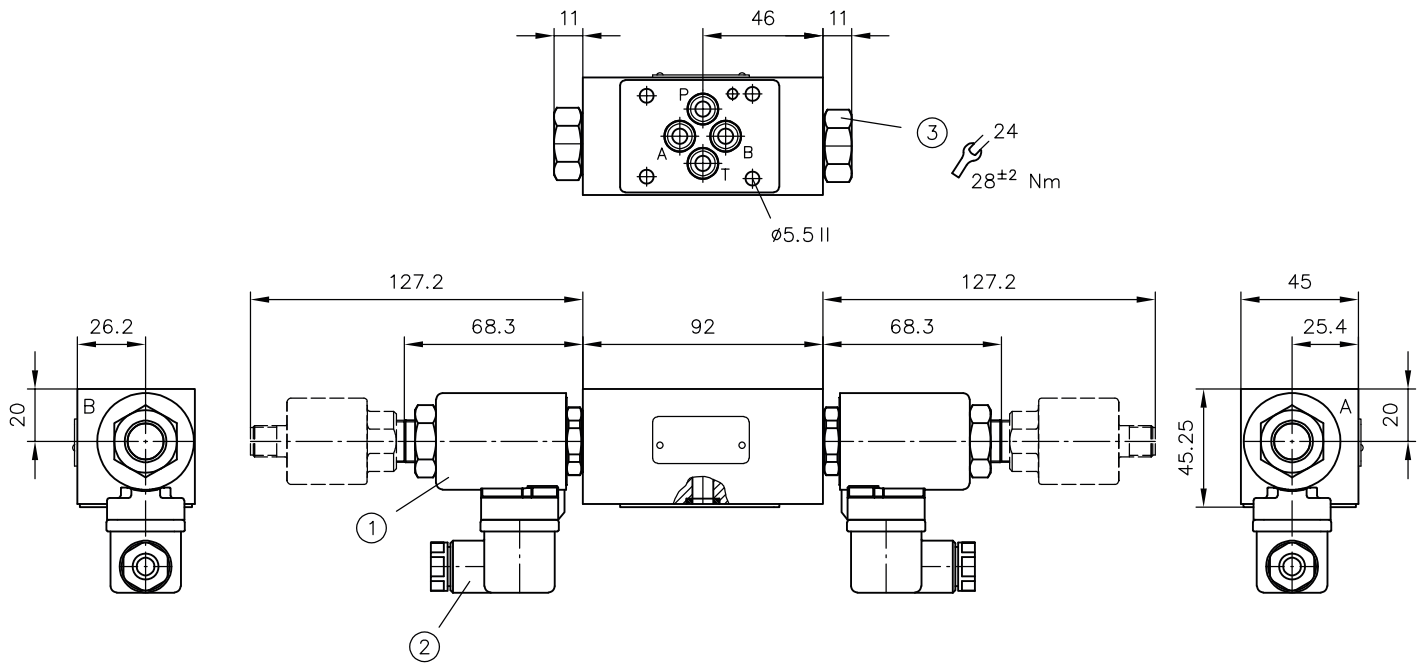

- 1 Solenoid version
- 2 Solenoid can be turned in any direction
- 3 Tapped plug for type NZP 16 SV8 X/ATBT
- 4 Version U with additional position switch

Actuation

X, G, WG

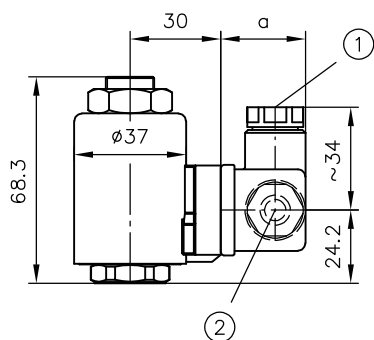

- 1 Cable fitting
- 2 Plug can be mounted offset by 4 x 90°

Version	a
G	28
W	34.5

L

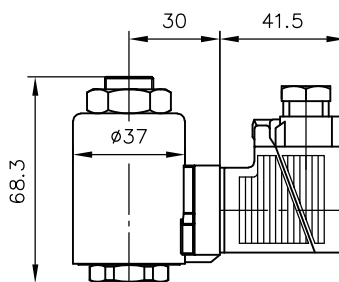

X, G for SV..U

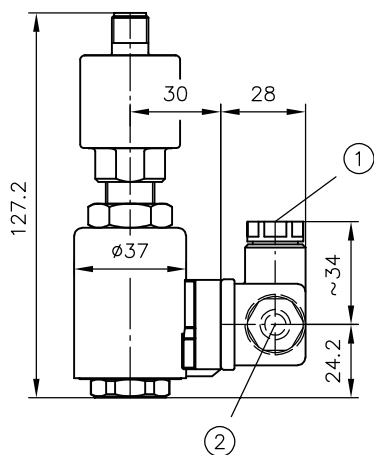

- 1 Cable fitting
- 2 Plug can be mounted offset by 4 x 90°

L for SV..U

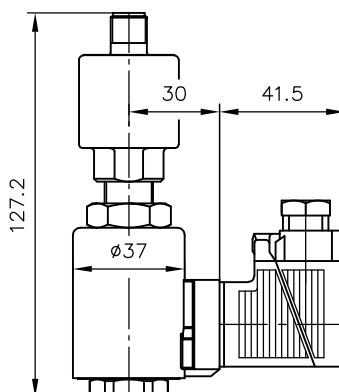

4.11 Intermediate plate with release valve P → T: NZP 16 BV 1Z, NZP 16 BV 1Y

NZP 16 BV 1Z
NZP 16 BV 1Y

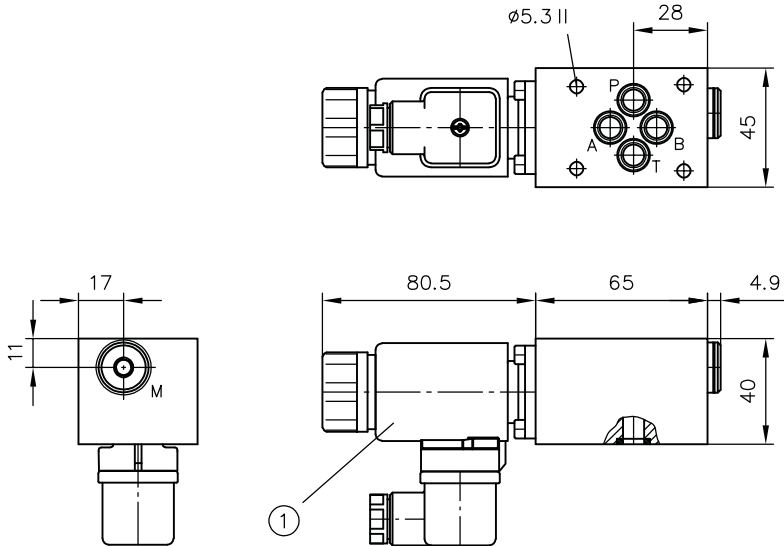

1 Solenoid GM.., WGM.., XM.., for other solenoid versions, see Chapter 4.5, "Intermediate plate with switchable pressure reducing valve at P: NZP 16 LZY"

Ports (ISO 228-1)

M	G 1/4
---	-------

i INFORMATION

Missing dimensions and hole pattern, see Chapter 4.1, "Intermediate plate with throttle valve: NZP 16 Q".

4.12 Intermediate plate with short-circuit valve P → A: NZP 16 PBV

NZP 16 PBV 1S
NZP 16 PBV 1R

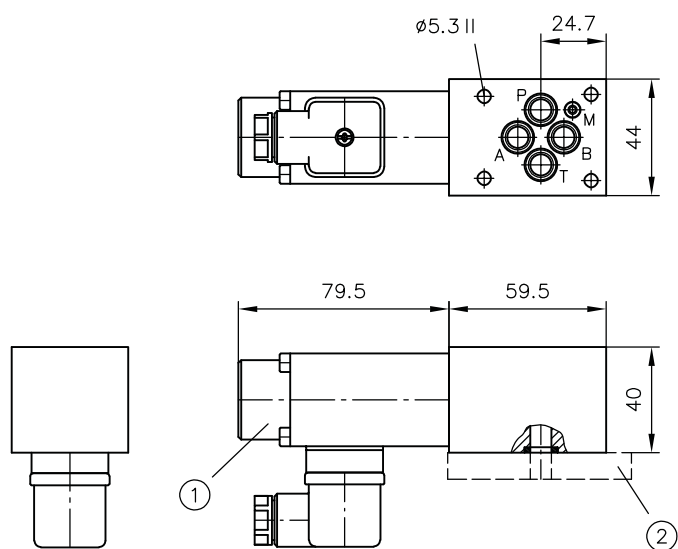

- 1 Solenoid G., WG., X., for other solenoid versions, see Chapter 4.5, "Intermediate plate with switchable pressure reducing valve at P: NZP 16 LZ"
- 2 Spacer plate 10 mm, only for version with explosion-proof solenoids (-X 24 EX 55 FM)

i INFORMATION

Missing dimensions and hole pattern, see Chapter 4.1, "Intermediate plate with throttle valve: NZP 16 Q".

Actuation

Pneumatic

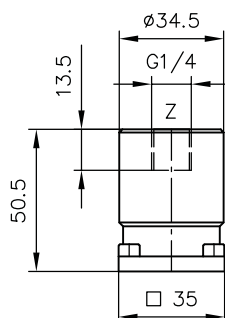

4.13 Intermediate plate with short-circuit valve A → T: NZP 16 ATBV

NZP 16 ATBV 1S
NZP 16 ATBV 1R

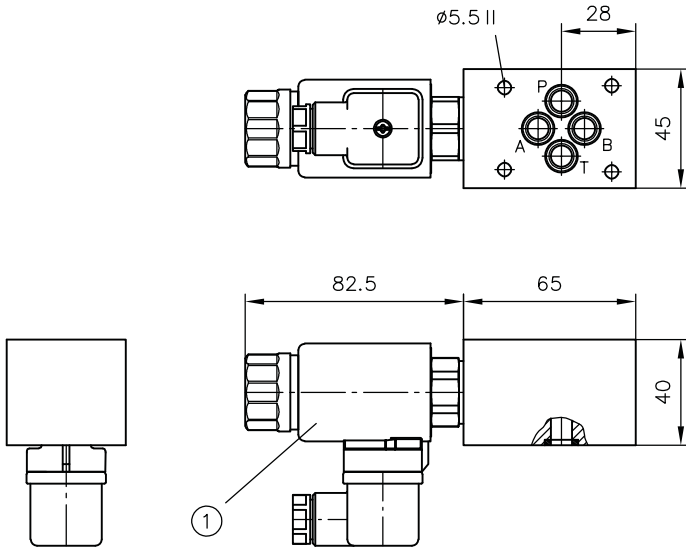

1 Solenoid GM..., WGM..., XM..., for other solenoid versions, see Chapter 4.5, "Intermediate plate with switchable pressure reducing valve at P: NZP 16 LZV"

i **INFORMATION**

Missing dimensions and hole pattern, see Chapter 4.1, "Intermediate plate with throttle valve: NZP 16 Q".

4.14 Intermediate plate with check valve at A or B: NZP 16 BV 1A.., NZP 16 BV 1B..

NZP 16 BV 1A..

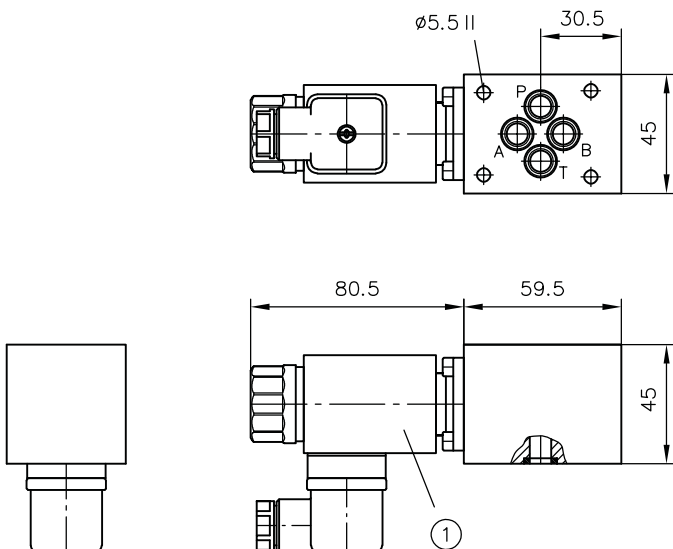

1 Solenoid G..., WG..., X..., for other solenoid versions, see Chapter 4.5, "Intermediate plate with switchable pressure reducing valve at P: NZP 16 LZV"

NZP 16 BV 1B..

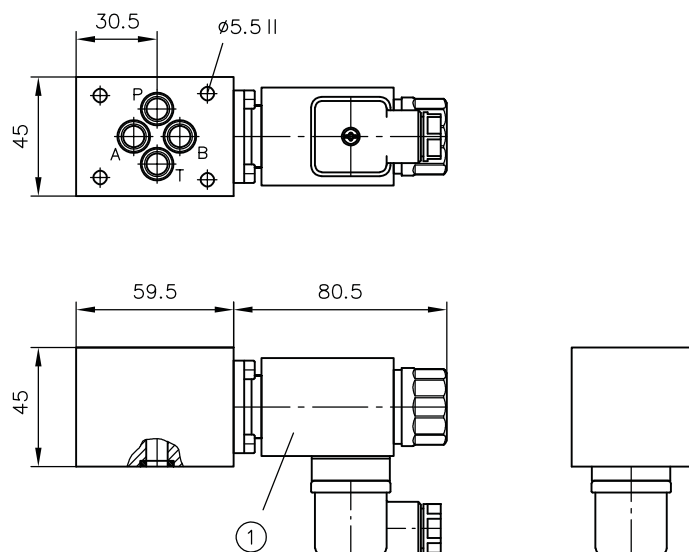

1 Solenoid G.., WG.., X.., for other solenoid versions, see Chapter 4.5, "Intermediate plate with switchable pressure reducing valve at P: NZP 16 LZV"

i INFORMATION

Missing dimensions and hole pattern, see Chapter 4.1, "Intermediate plate with throttle valve: NZP 16 Q".

4.15 Intermediate plate with 4/4-way directional valve: NZP 16 BV 1A..-B..

NZP 16 BV 1AS-BS, NZP 16 BV 1AR-BR
NZP 16 BV 1AS-BR, NZP 16 BV 1AR-BS

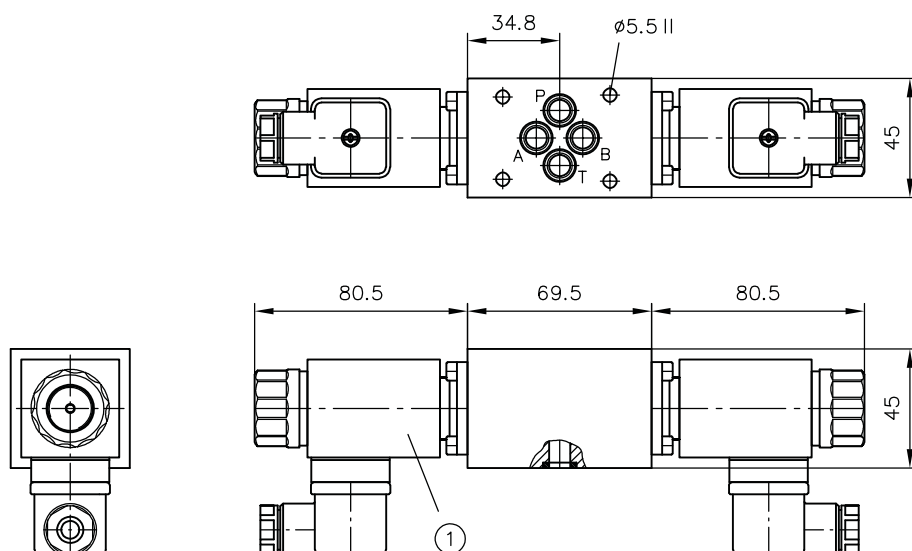

1 Solenoid G.., WG.., X.., for other solenoid versions, see Chapter 4.5, "Intermediate plate with switchable pressure reducing valve at P: NZP 16 LZV"

i INFORMATION

Missing dimensions and hole pattern, see Chapter 4.1, "Intermediate plate with throttle valve: NZP 16 Q".

Actuation

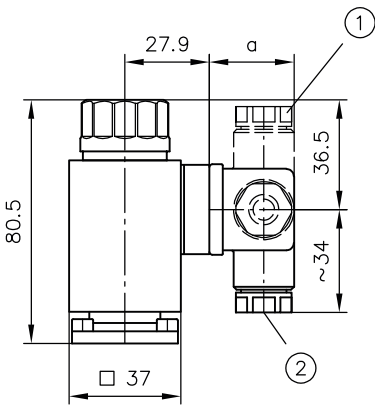

Version	a
G	28
WG	34,5

- 1 Plug can be mounted offset 4x 90°
- 2 Cable fitting

4.16 Intermediate plate with short-circuit valve B → A: NZP 16 BV 1S, NZP 16 BV 1R

NZP 16 BV 1S
NZP 16 BV 1R

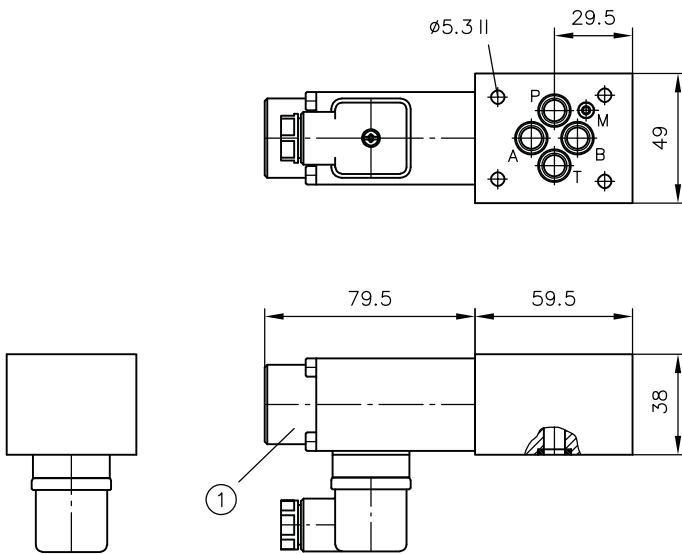

- 1 Solenoid G., WG., X., for other solenoid versions, see Chapter 4.5, "Intermediate plate with switchable pressure reducing valve at P: NZP 16 LZ"

NZP 26 BV 1S
NZP 26 BV 1R

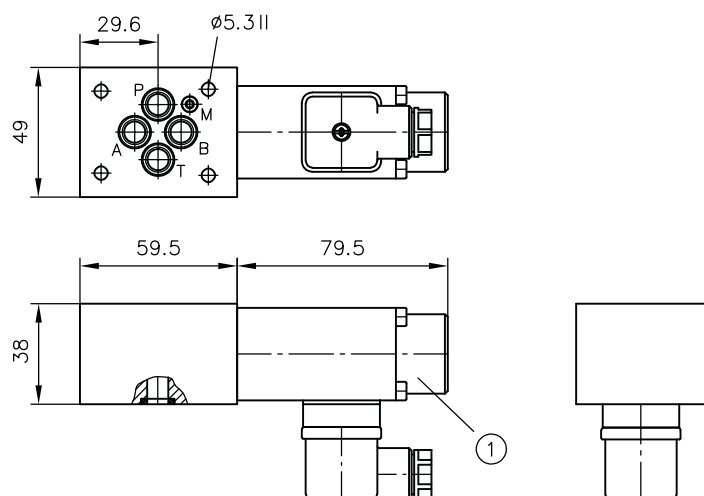

1 Solenoid G., WG., X., for other solenoid versions, see Chapter 4.5, "Intermediate plate with switchable pressure reducing valve at P: NZP 16 LZ"

i INFORMATION

Missing dimensions and hole pattern, see Chapter 4.1, "Intermediate plate with throttle valve: NZP 16 Q".

4.17 Intermediate plate with release valve A/B → T: NZP 16 BV 1K, NZP 16 BV 1Q

NZP 16 BV 1K
NZP 16 BV 1Q

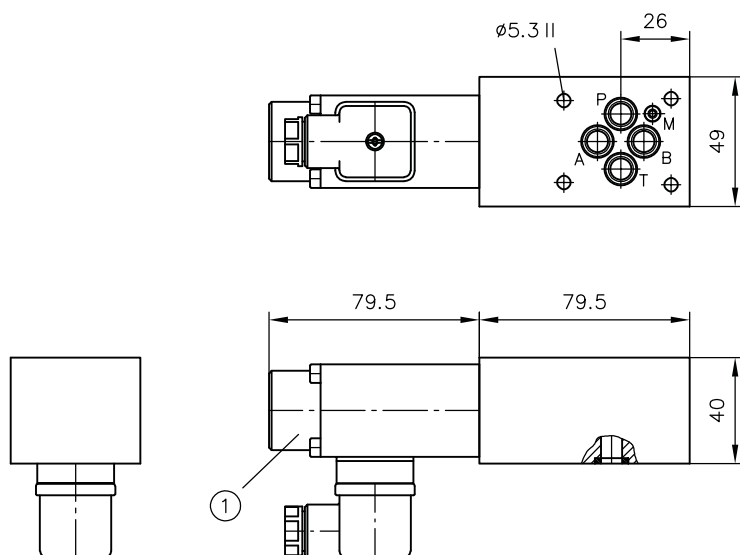

1 Solenoid G., WG., X., for other solenoid versions, see Chapter 4.5, "Intermediate plate with switchable pressure reducing valve at P: NZP 16 LZ"

i INFORMATION

Missing dimensions and hole pattern, see Chapter 4.1, "Intermediate plate with throttle valve: NZP 16 Q".

4.18 Intermediate plate with pendulum valve A → or B → T: NZP 16 BV 1RS, NZP 16 BV 1SR

NZP 16 BV 1RS
NZP 16 BV 1SR

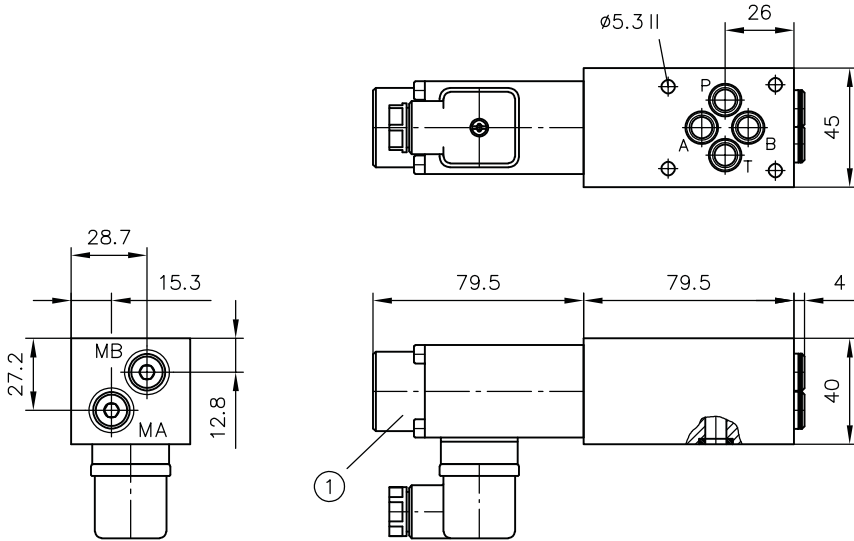

1 Solenoid G., WG., X., for other solenoid versions, see Chapter 4.5, "Intermediate plate with switchable pressure reducing valve at P: NZP 16 LZV"

Ports (ISO 228-1)

MA, MB	G 1/8
--------	-------

i INFORMATION

Missing dimensions and hole pattern, see Chapter 4.1, "Intermediate plate with throttle valve: NZP 16 Q".

4.19 Intermediate plate with quick shut-down valve: SK 7788 590

SK 7788 590

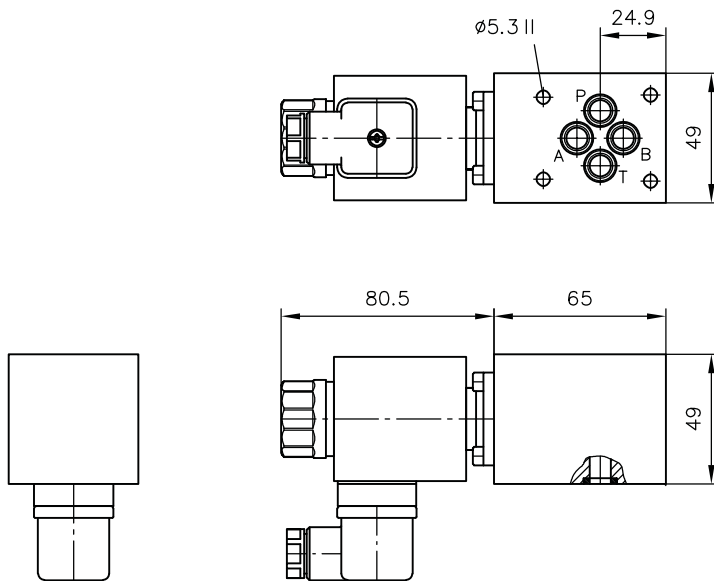

i INFORMATION

Missing dimensions and hole pattern, see Chapter 4.1, "Intermediate plate with throttle valve: NZP 16 Q".

Actuation

Electrical

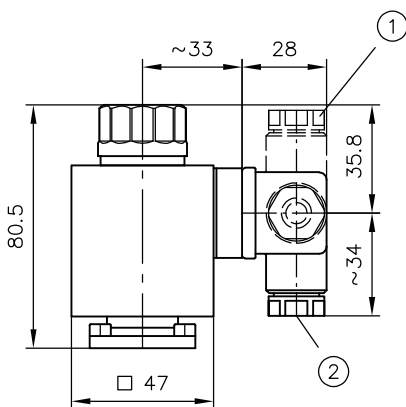

- 1 Plug can be mounted offset by $4 \times 90^\circ$
- 2 Cable gland

Hydraulic

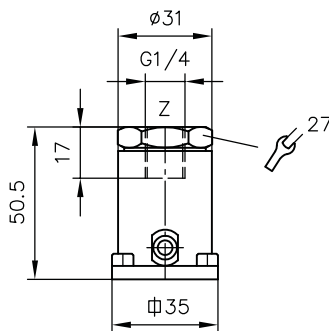

4.20 Intermediate plate with releasable check valves at A and B: NZP 16 ADRH

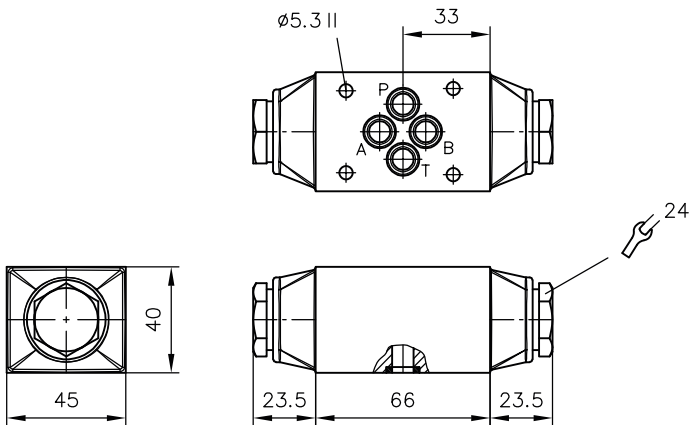

4.21 Intermediate plate with shock valve: NZP 16 AN.. and others

NZP 16 AN.., NZP 16 AXN..
NZP 16 A.., NZP 16 AX..

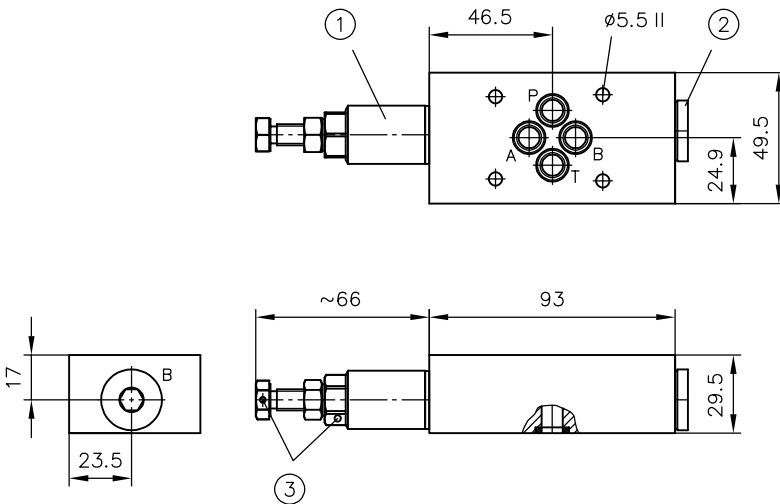

- 1 Pressure control valve in the A channel
- 2 Tapped plug
- 3 Sealing option

NZP 16 BN..
NZP 16 B..

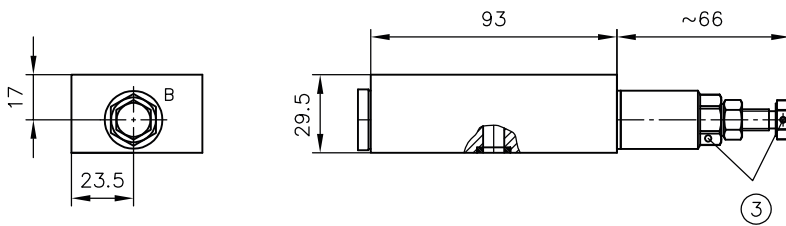
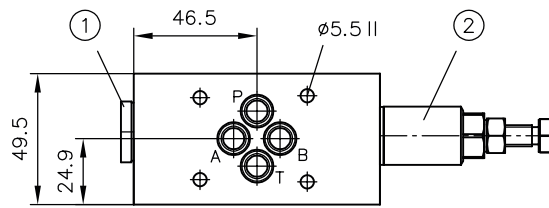

- 1 Tapped plug
- 2 Pressure control valve in the B channel
- 3 Sealing option

NZP 16 A..B..
NZP 16 AX..BX..

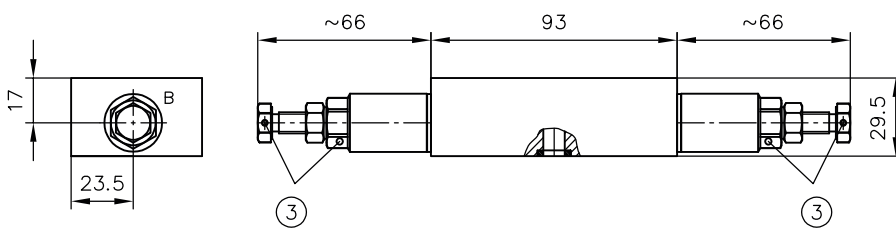
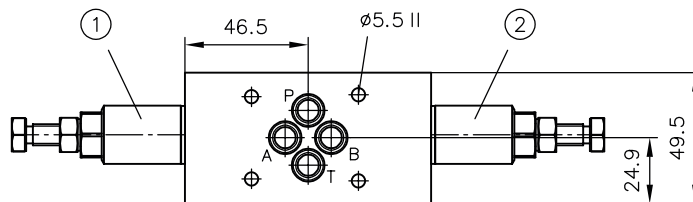

- 1 Pressure control valve in the A channel
- 2 Pressure control valve in the B channel
- 3 Sealing option

NZP 16 ANBN
NZP 16 AXBX

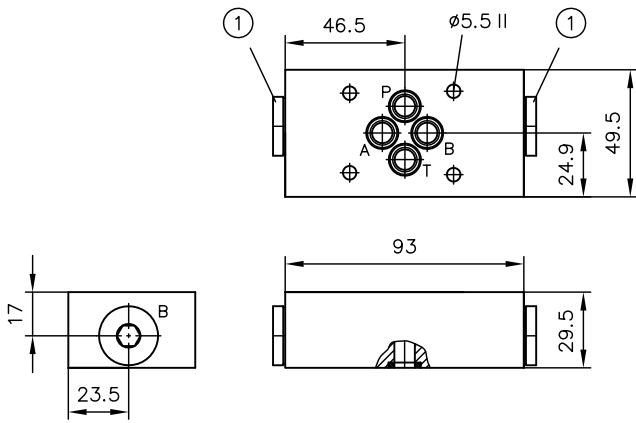

1 Tapped plug

i INFORMATION

Missing dimensions and hole pattern, see Chapter 4.1, "Intermediate plate with throttle valve: NZP 16 Q".

4.22 Intermediate plate with load-holding valve: NZP 16 AL, NZP 16 BL

NZP 16 AL..
NZP 16 BL..
NZP 16 AL --BL --

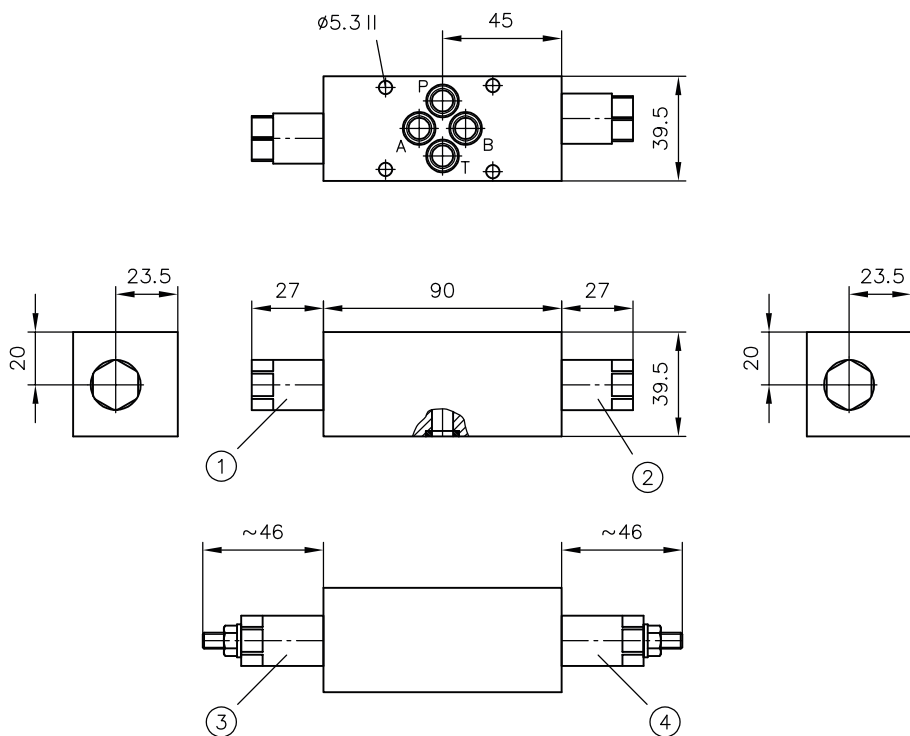

- 1 Omitted for type NZP 16 BL
- 2 Omitted for type NZP 16 AL
- 3 Omitted for type NZP 16 BL..V
- 4 Omitted for type NZP 16 AL..V

i INFORMATION

Missing dimensions and hole pattern, see Chapter 4.1, "Intermediate plate with throttle valve: NZP 16 Q".

4.23 Spacer plate

NZP 16 D

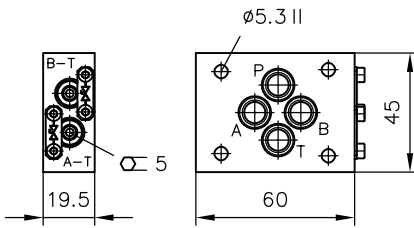

NZP 16 Z10

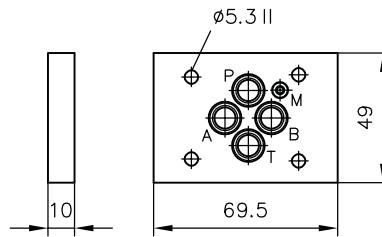

NZP 16 ZA RB
NZP 16 ZA RK

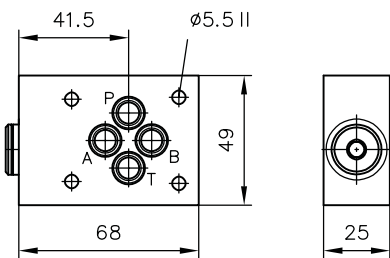

NZP 16 AB-BA

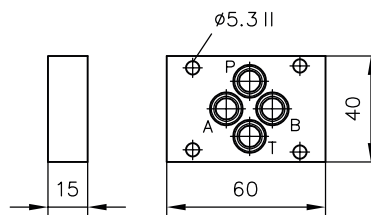

i INFORMATION

Missing dimensions and hole pattern, see Chapter 4.1, "Intermediate plate with throttle valve: NZP 16 Q".

5 Installation, operation and maintenance information

Observe the document B 5488 "General operating instructions for assembly, commissioning, and maintenance."

5.1 Intended use

This product is intended exclusively for hydraulic applications (fluid technology).

The user must observe the safety measures and warnings in this document.

Essential requirements for the product to function correctly and safely:

- ▶ All information in this documentation must be observed. This applies in particular to all safety measures and warnings.
- ▶ The product must only be assembled and put into operation by specialist personnel.
- ▶ The product must only be operated within the specified technical parameters described in detail in this document.
- ▶ All components must be suitable for the operating conditions when using an assembly.
- ▶ The operating instructions for the components, assemblies and the specific complete system must also always be observed.

If the product can no longer be operated safely:

1. Remove the product from operation and mark it accordingly.
 - ✓ It is then not permitted to continue using or operating the product.

5.2 Assembly information

The product must only be installed in the complete system with standard and compliant connection components (screw fittings, hoses, pipes, fixtures etc.).

The product must be shut down correctly prior to disassembly (in particular in combination with hydraulic accumulators).

DANGER

Sudden movement of the hydraulic drives when disassembled incorrectly

Risk of serious injury or death

- ▶ Depressurise the hydraulic system.
- ▶ Perform safety measures in preparation for maintenance.

5.3 Operating instructions

Observe product configuration and pressure/flow rate.

The statements and technical parameters in this document must be strictly observed.

The instructions for the complete technical system must also always be followed.

NOTICE

- ▶ Read the documentation carefully before usage.
- ▶ The documentation must be accessible to the operating and maintenance staff at all times.
- ▶ Keep documentation up to date after every addition or update.

CAUTION

Overloading components due to incorrect pressure settings.

Risk of minor injury. Parts may burst or fly off, and uncontrolled leakage of hydraulic fluid.

- Pay attention to the maximum operating pressure of the pump, valves and fittings.
- Always monitor the pressure gauge when setting and changing the pressure.

Purity and filtering of the hydraulic fluid

Fine contamination can significantly impair the function of the product. Contamination can cause irreparable damage.

Examples of fine contamination include:

- Swarf
- Rubber particles from hoses and seals
- Dirt due to assembly and maintenance
- Mechanical debris
- Chemical ageing of the hydraulic fluid

! NOTICE

New hydraulic fluid from the manufacturer may not have the required purity.

Damage to the product is possible.

- ▶ Filter new hydraulic fluid to a high quality when filling.
- ▶ Do not mix hydraulic fluids. Always use hydraulic fluid that is from the same manufacturer, of the same type, and with the same viscosity properties.

For smooth operation, pay attention to the cleanliness level of the hydraulic fluid (cleanliness level [see Chapter 3, "Parameters"](#)).

Additionally applicable document: [D 5488/1](#) oil recommendations

5.4 Maintenance information

Check regularly (at least once a year) by visual inspection whether the hydraulic connections are damaged. If external leakages are found, shut down and repair the system.

Clean the surface of the device regularly (at least once a year) (dust deposits and dirt).

References

Additional versions

- Directional seated valve type NG, NGW and others: D 7300 N
- Directional seated valve type NBVP 16: D 7765 N
- Directional seated valve type ROLV: D 8144
- Directional spool valve type NSWP 2: D 7451 N
- Valve bank (nominal size 6) type BA: D 7788
- Valve bank type BNG: D 7788 BNG

